

System M

Fräs- und Montageanleitung

FritsJurgens Set - 70 mm Klasse C - Unsichtbar

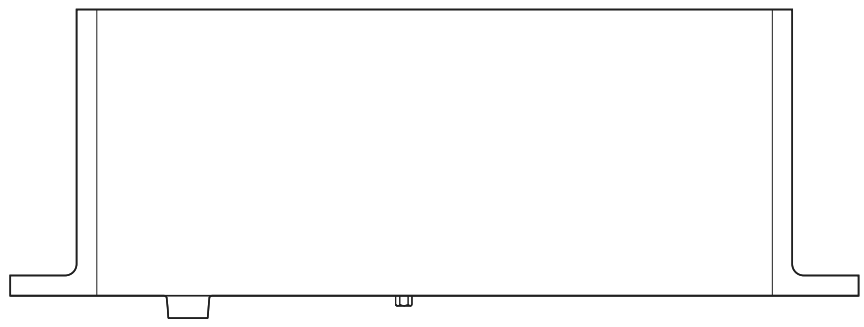

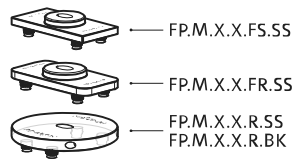
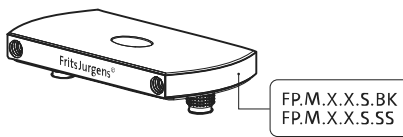
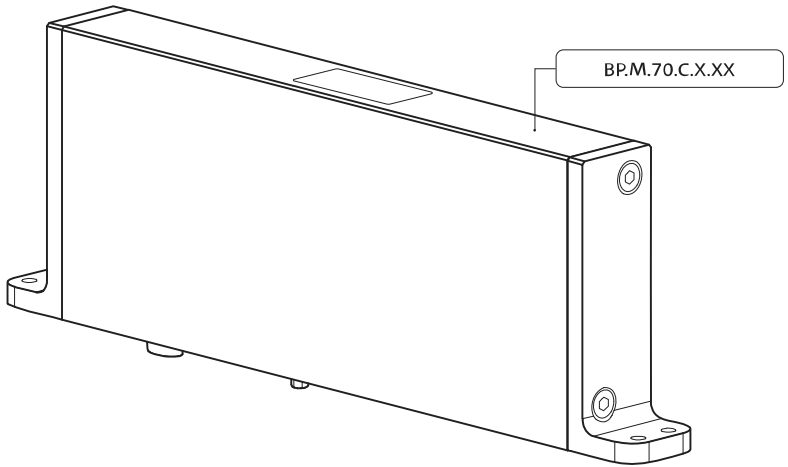
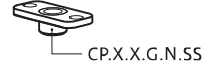
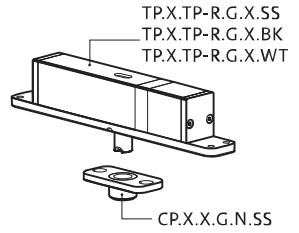
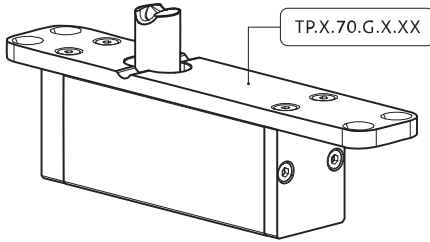
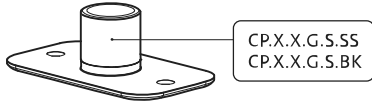

Fräsanleitung

BP.M.70.C.X.XX

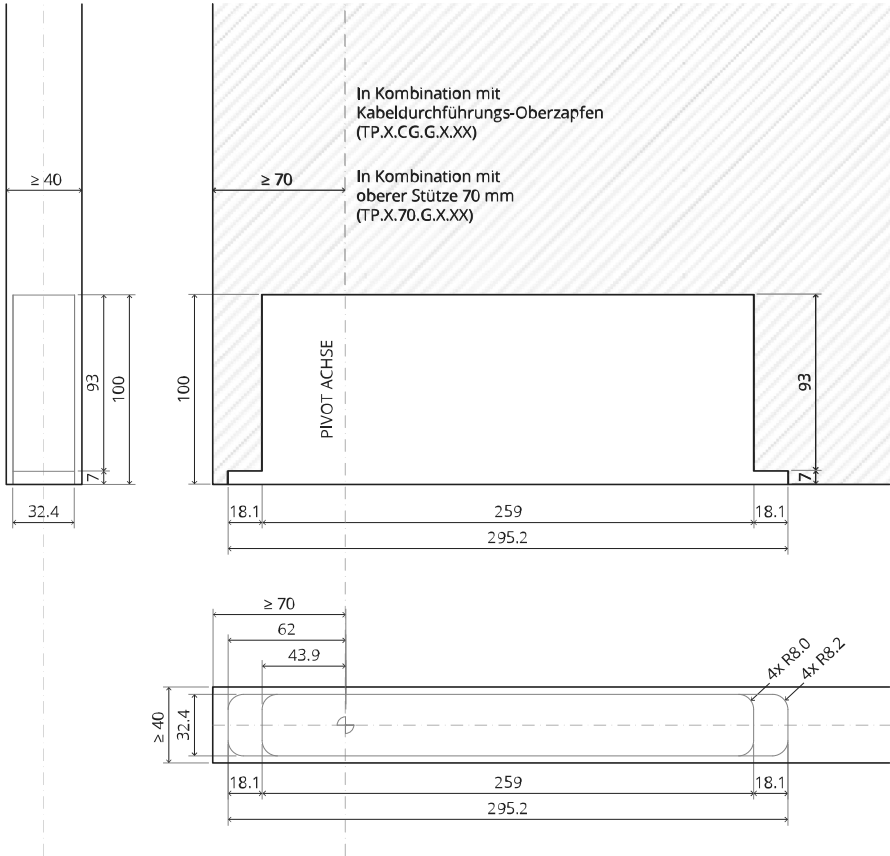

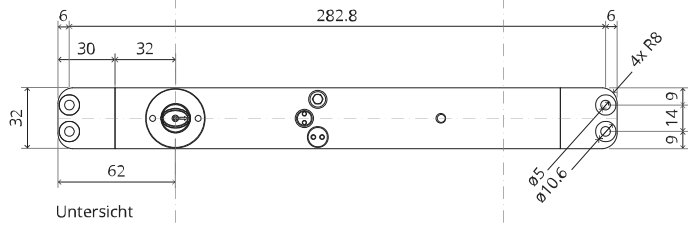
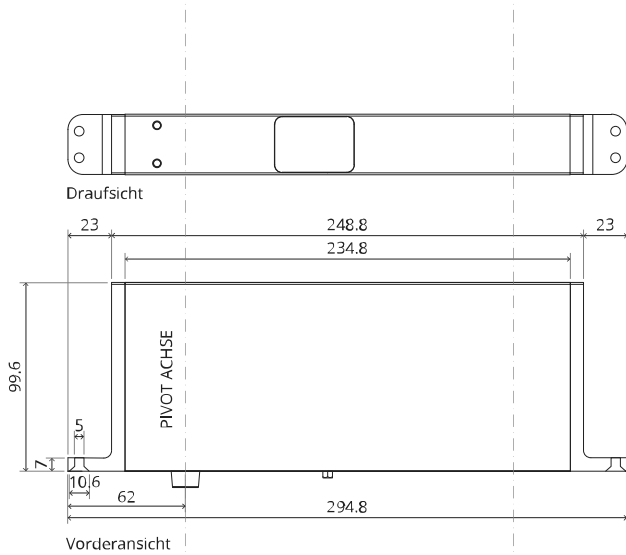
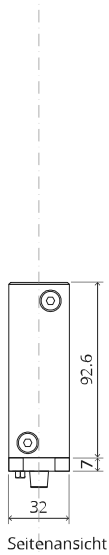

TP.X.70.G.X.XX

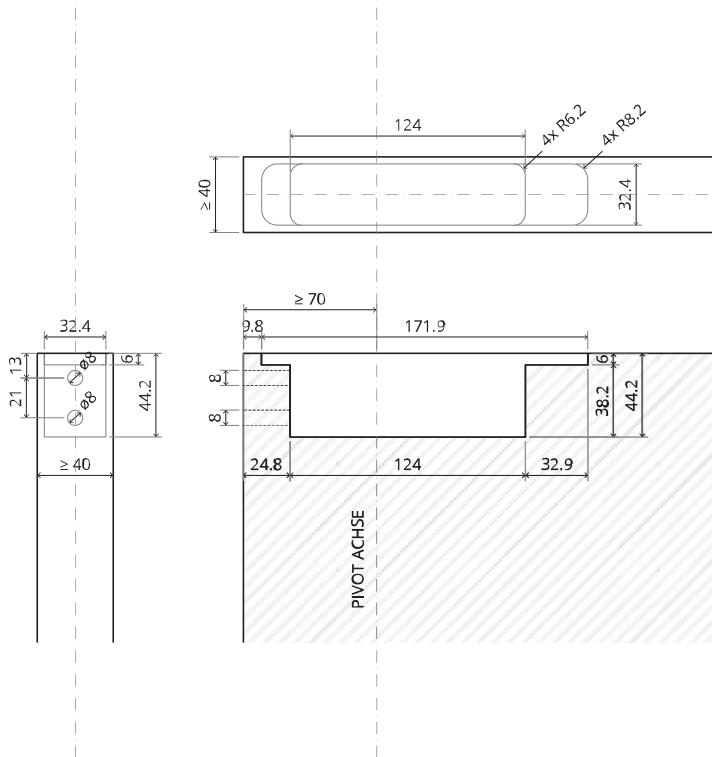



Seitenansicht A
mit nach innen
gedrehtem Stift

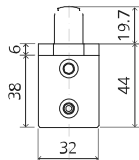

Seitenansicht A mit
herausgedrehtem Stift

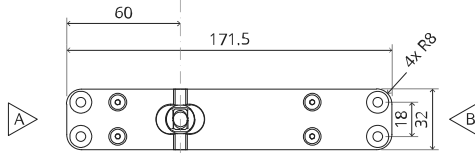

Draufsicht

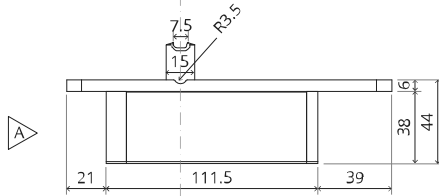

Vorderansicht

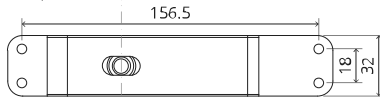

Untersicht

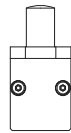

Seitenansicht B

TP.X.TP-R.G.X.

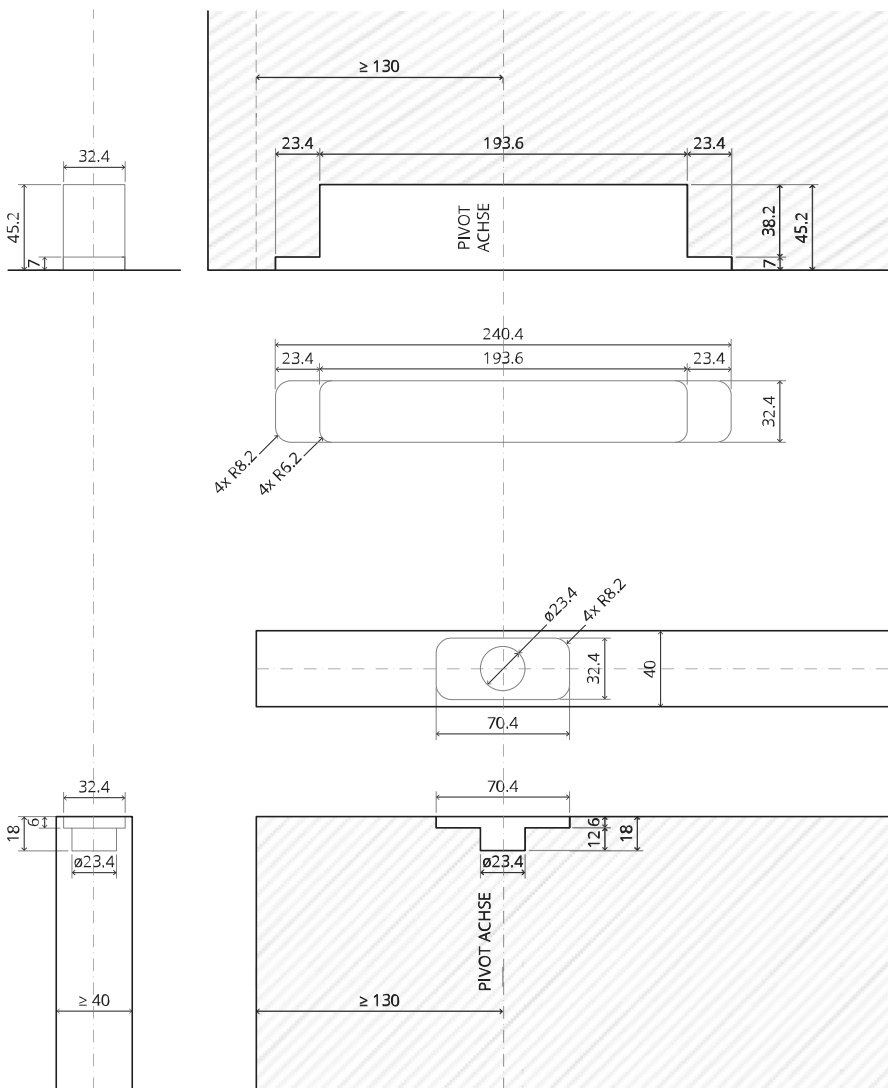

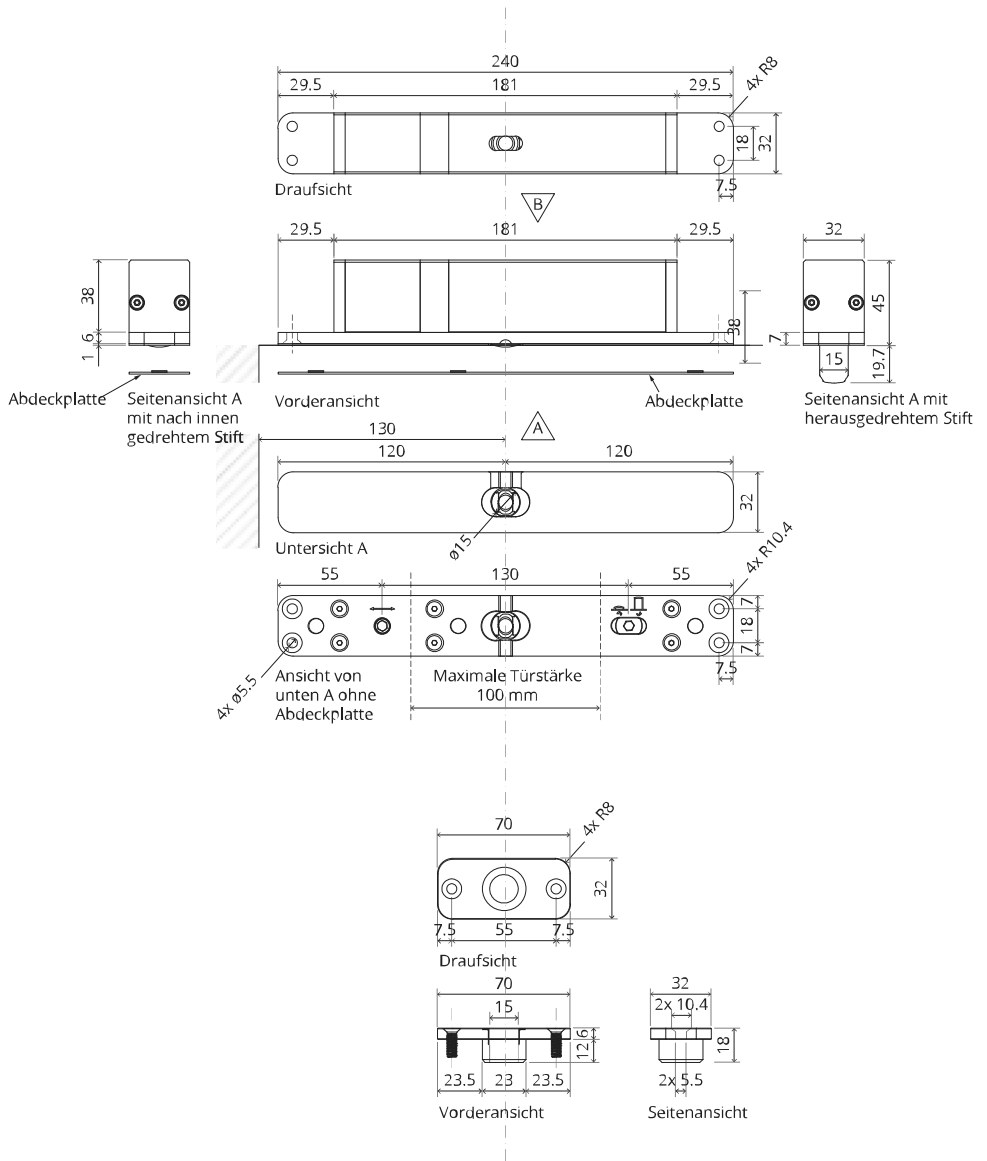

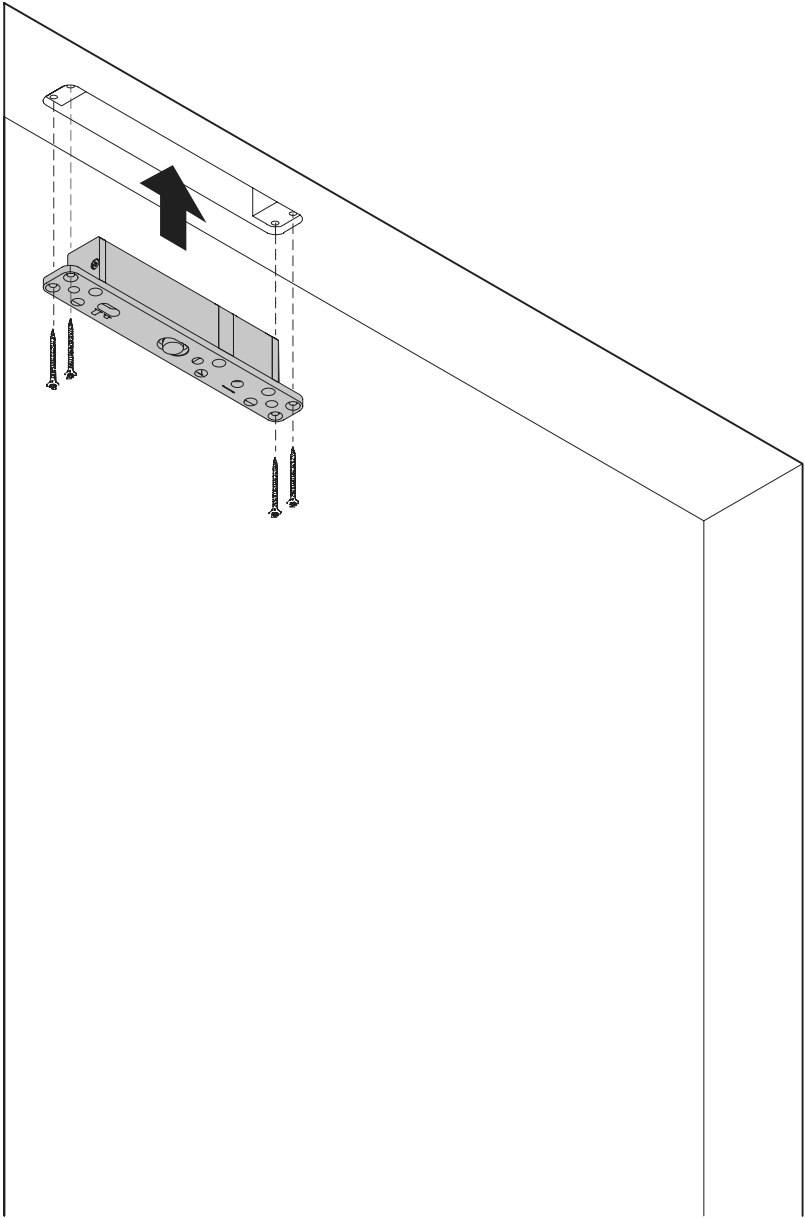

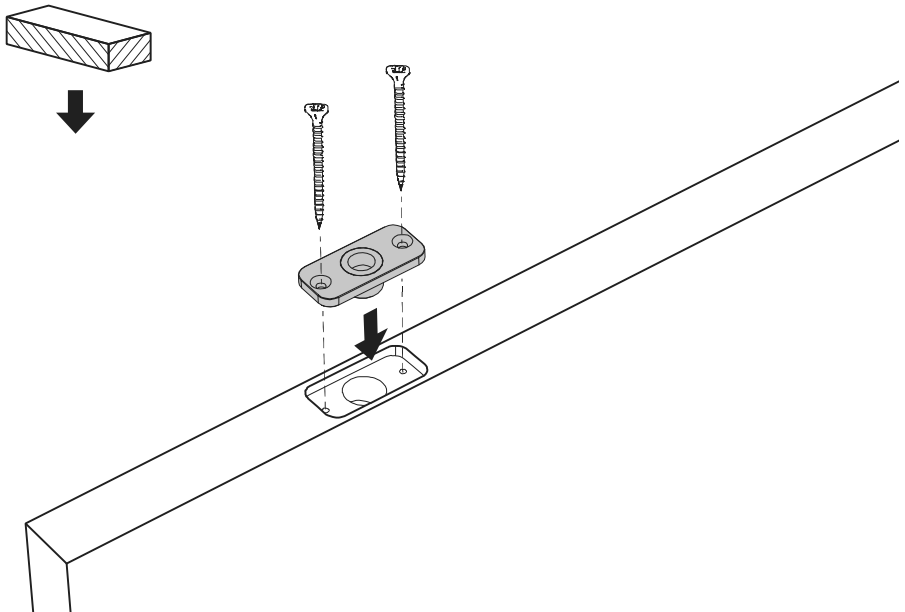
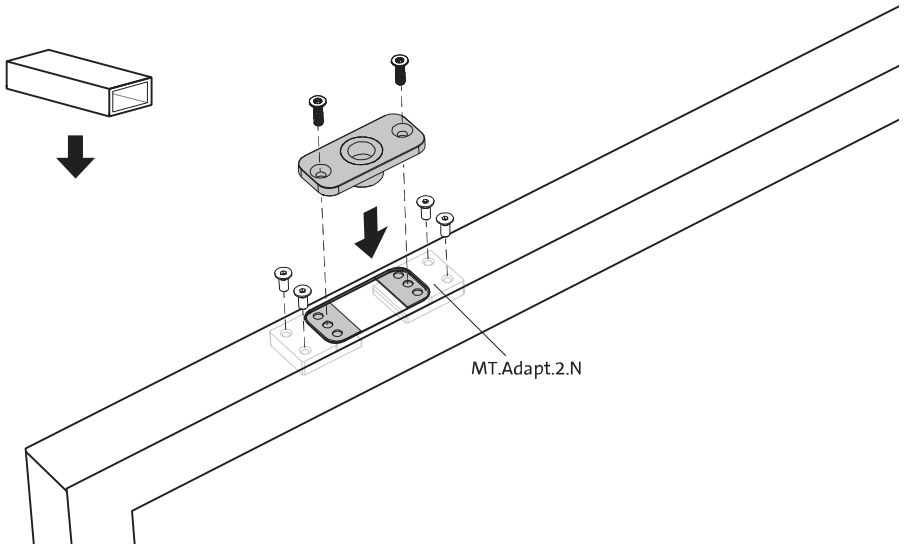

FP.M.X.X.FS.SS

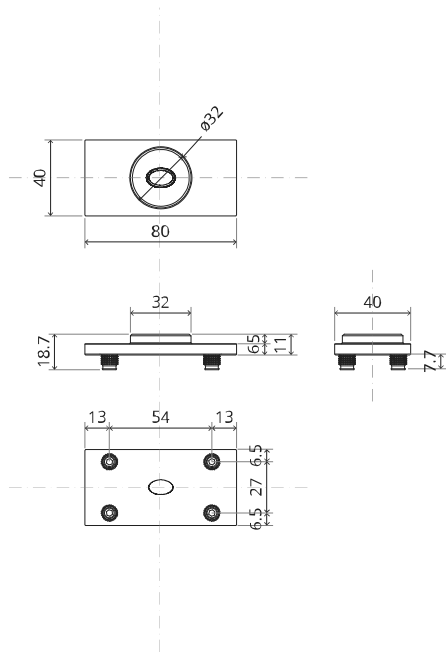
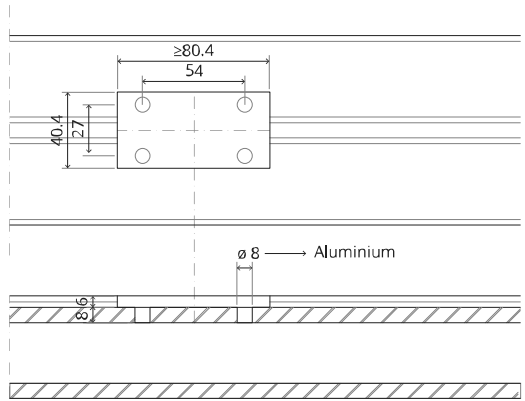

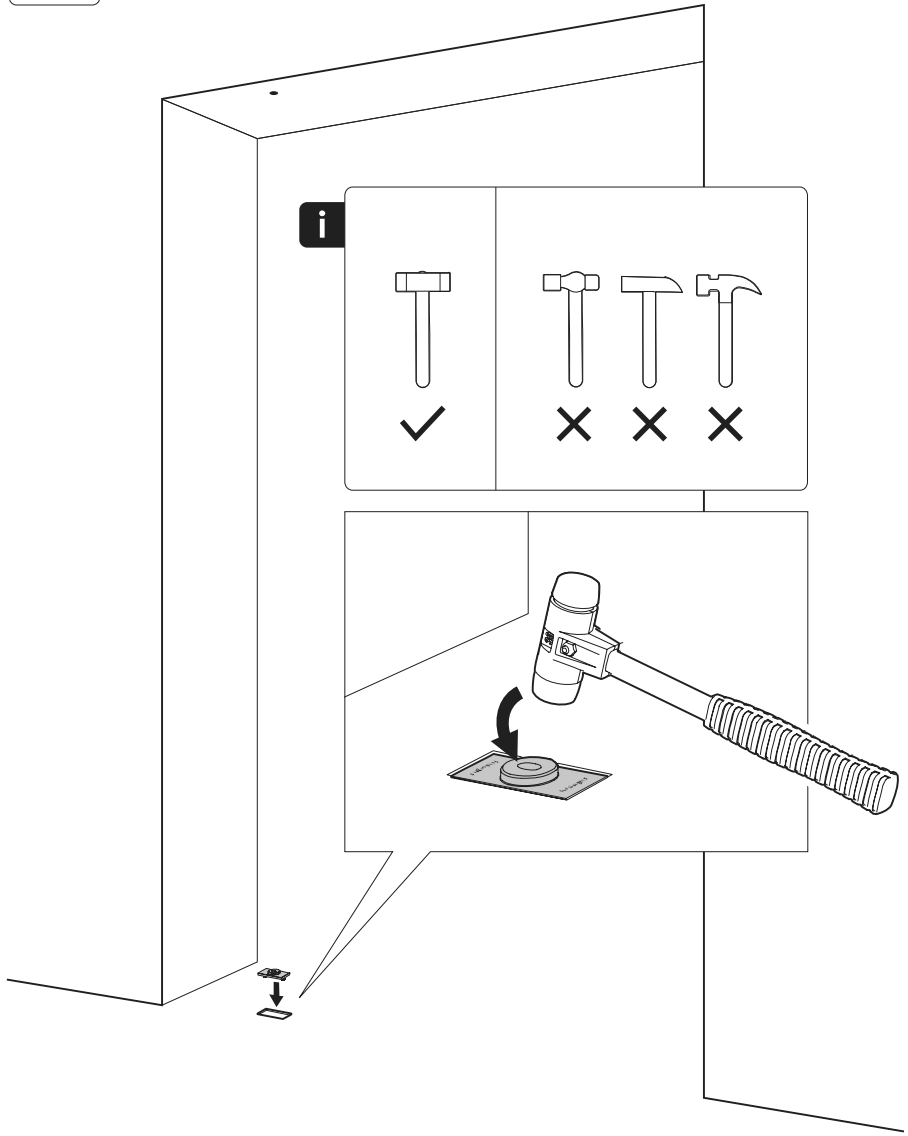

FP.M.X.X.FR.SS

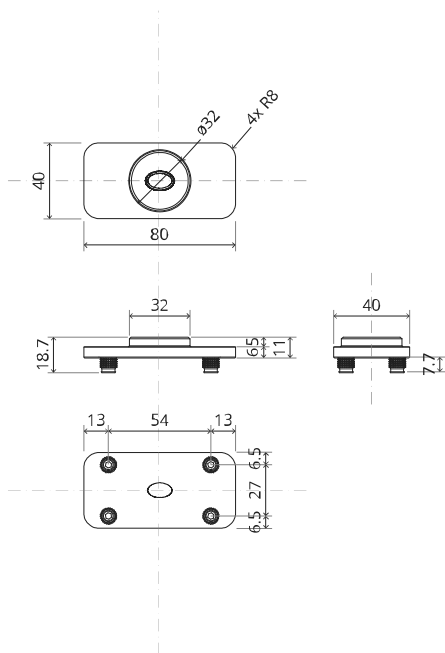
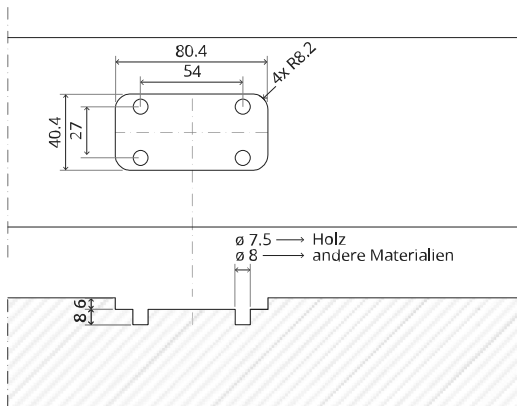

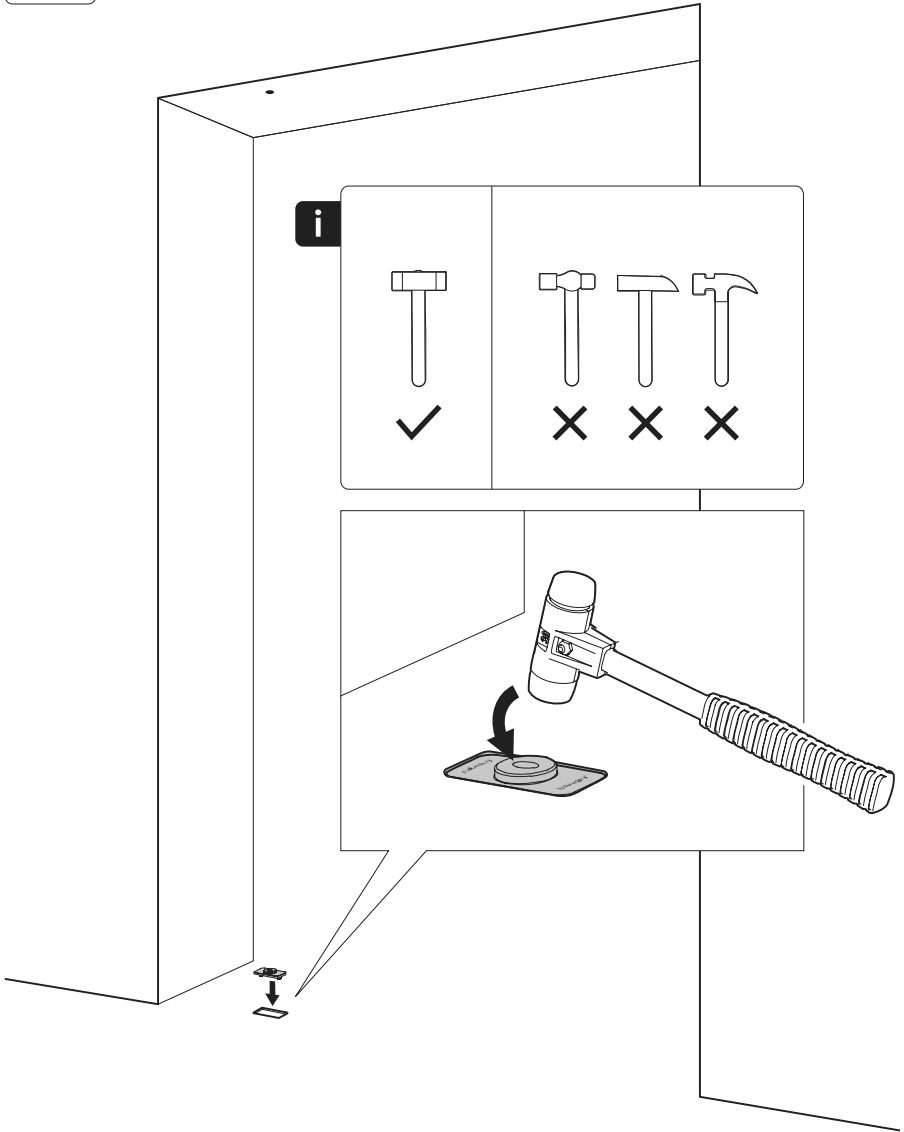

Montageanleitung

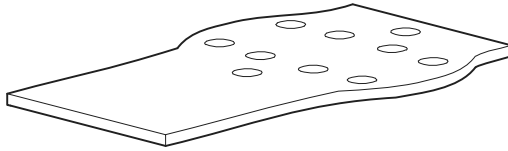

FJ.MT.DT.M

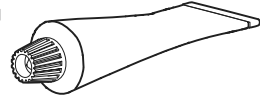

FJ.MT.ZS



FJ.MT.AK3

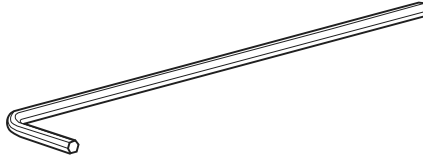

FJ.MT.AK5x24



10x FJ.Tx.4.0X50.PKDD



FJ.Bit.Tx20

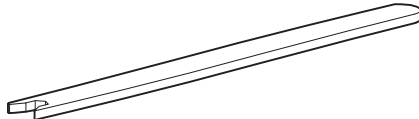

FJ.MT.AS.M

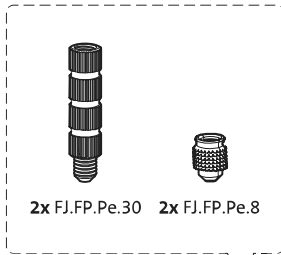

2x FJ.FP.Pe.30 2x FJ.FP.Pe.8

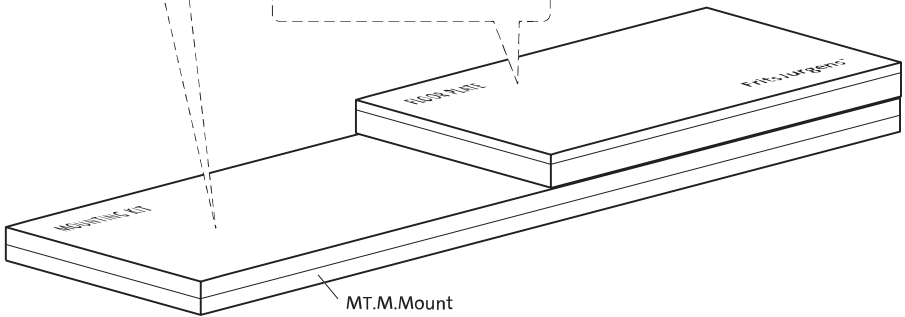

MT.M.Mount

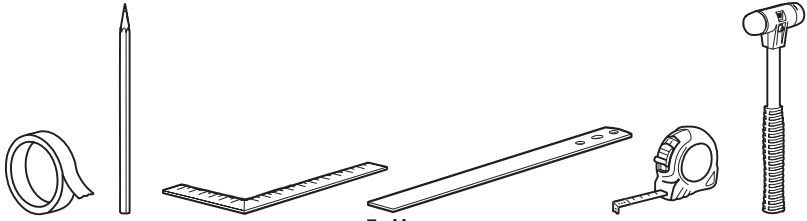

To.M

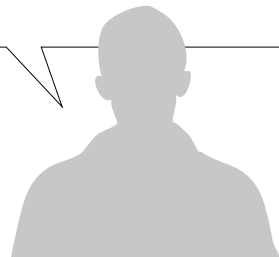
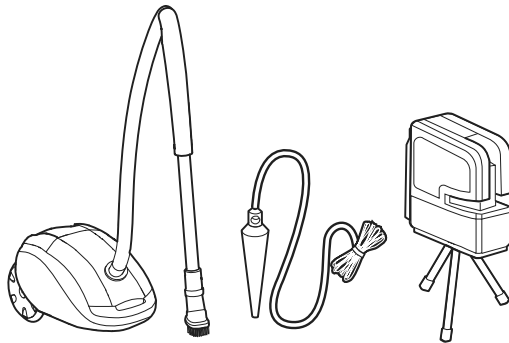
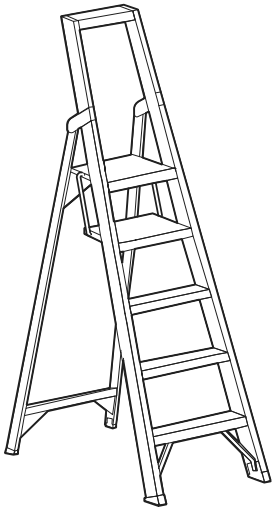
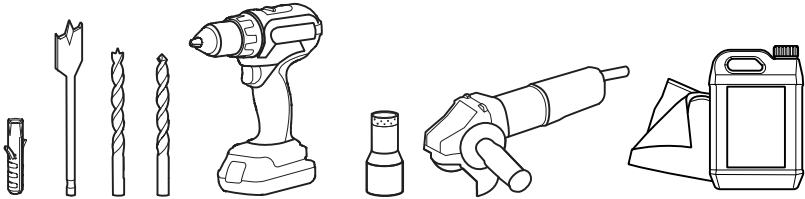

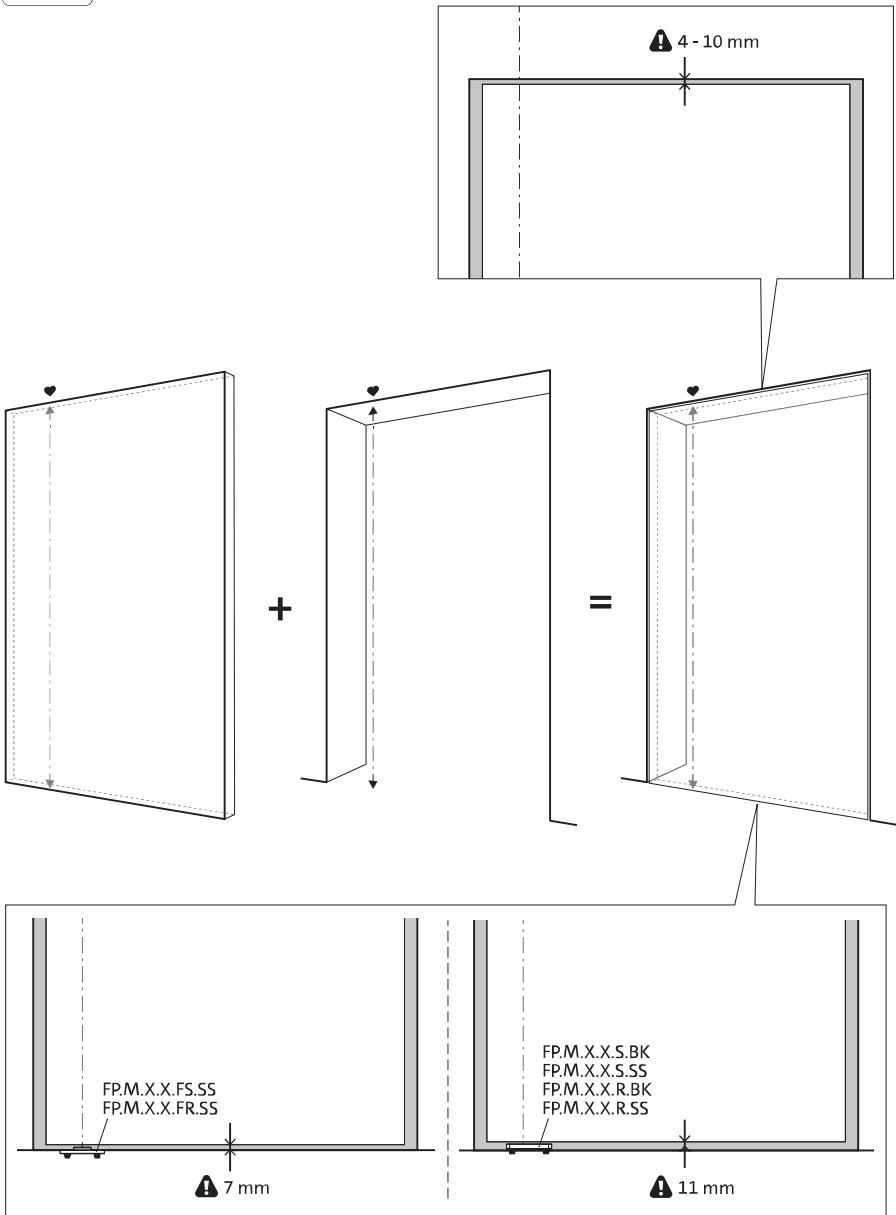

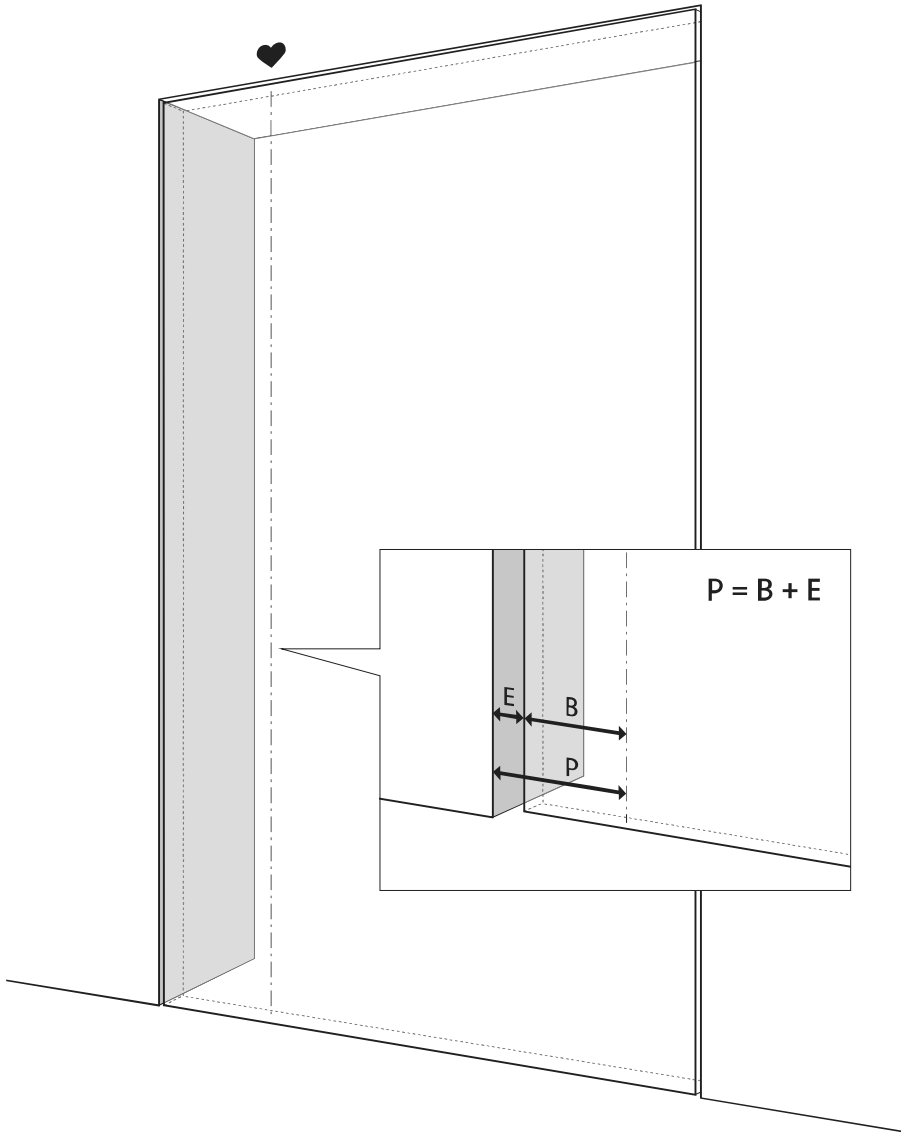

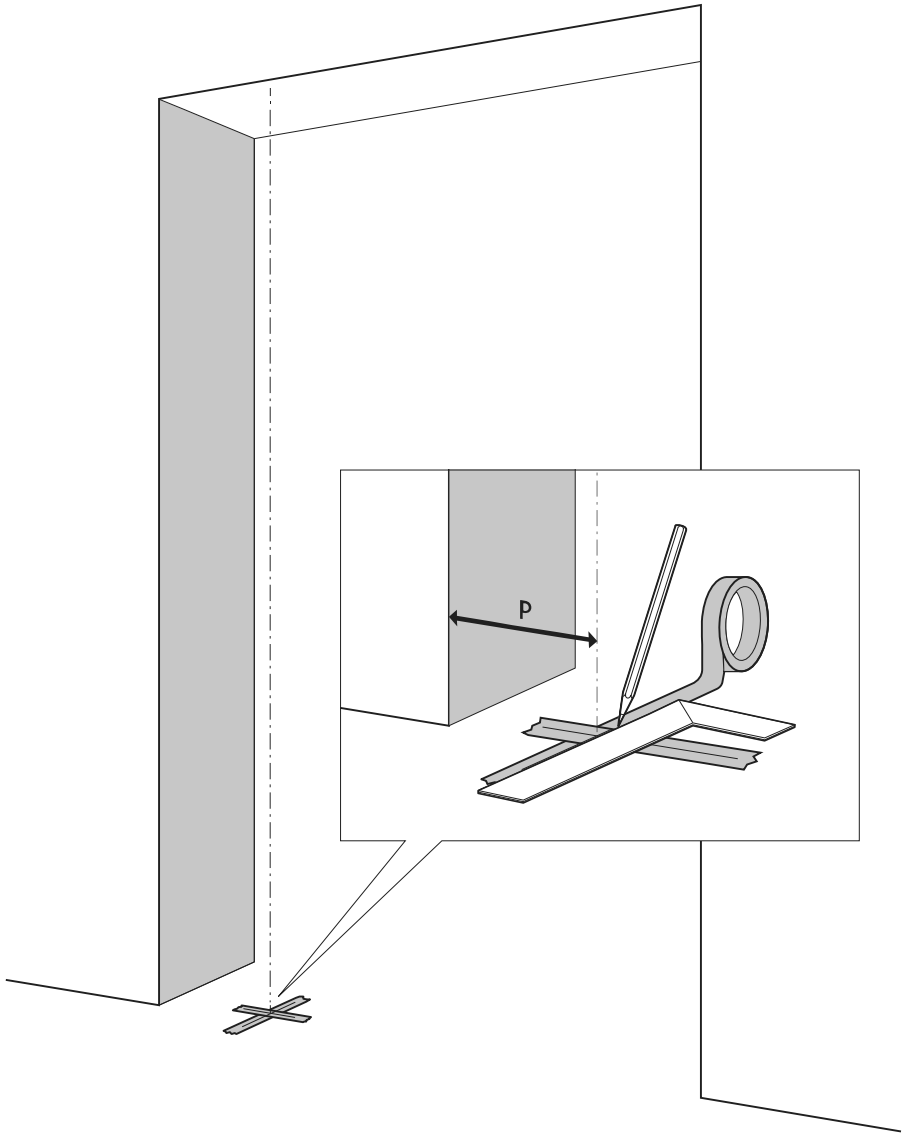

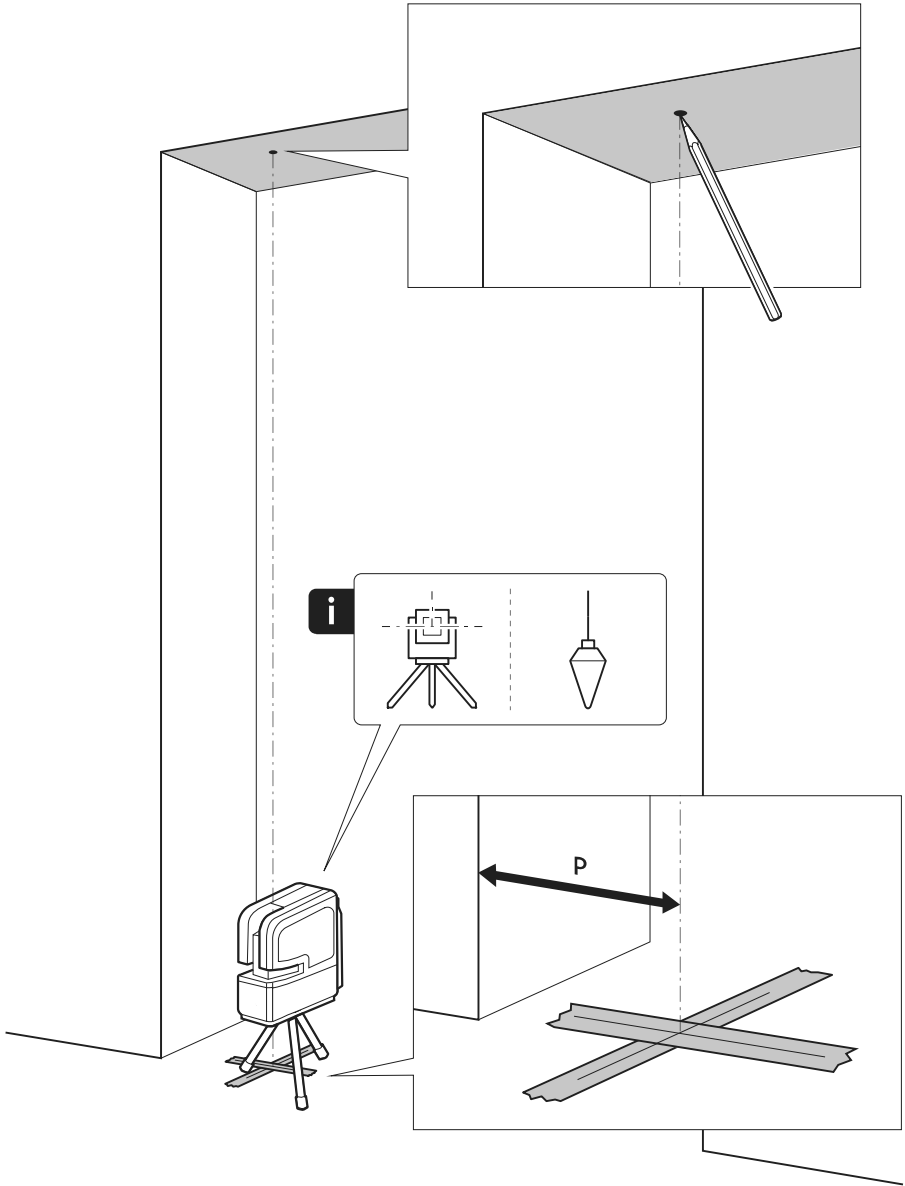
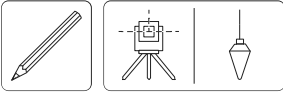

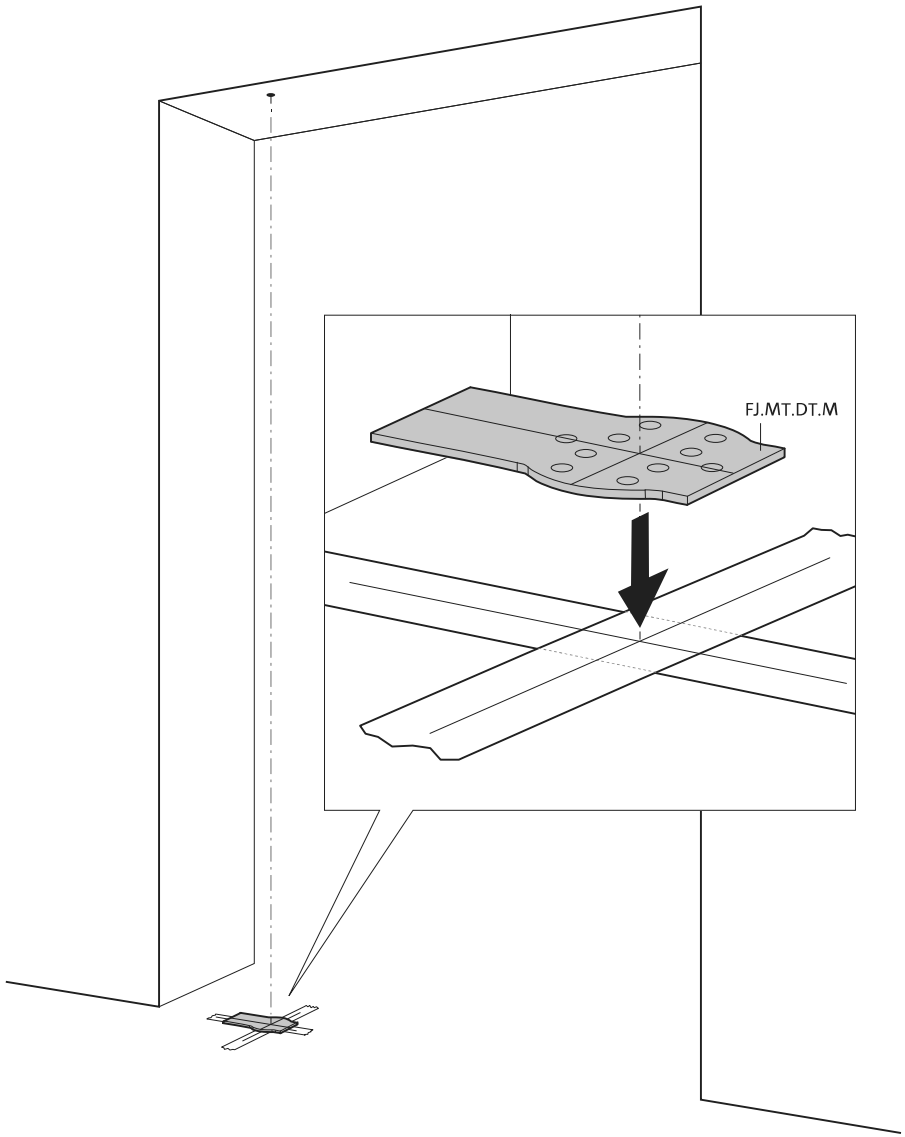

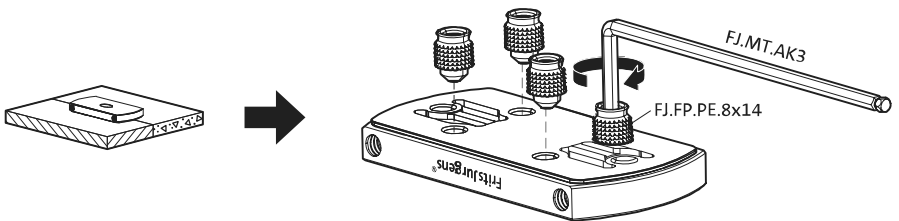
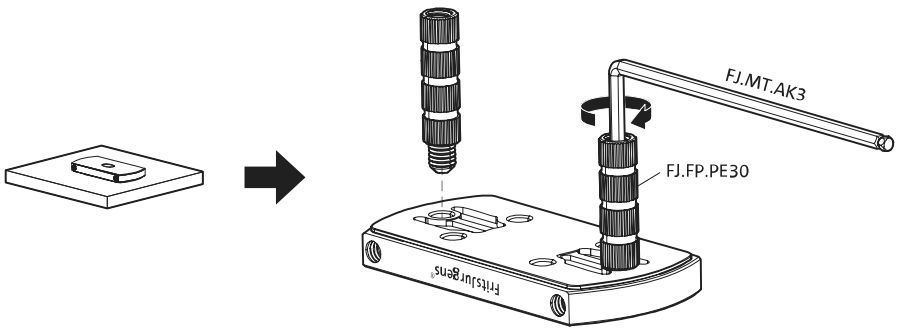
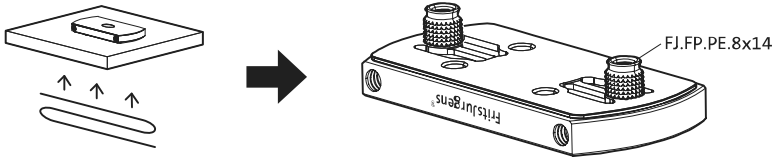

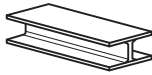

ø8 mm (5/16")

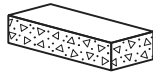

ø8 mm (5/16")

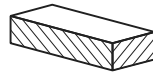

ø7.5 mm (19/64")

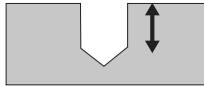

8 mm (5/16")

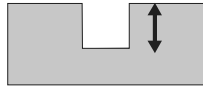

8 mm (5/16")

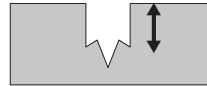

8 mm (5/16")

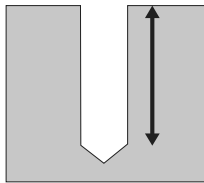
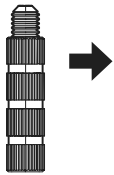

30 mm (13/16")

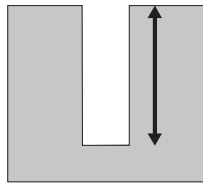

30 mm (13/16")

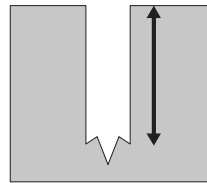

30 mm (13/16")

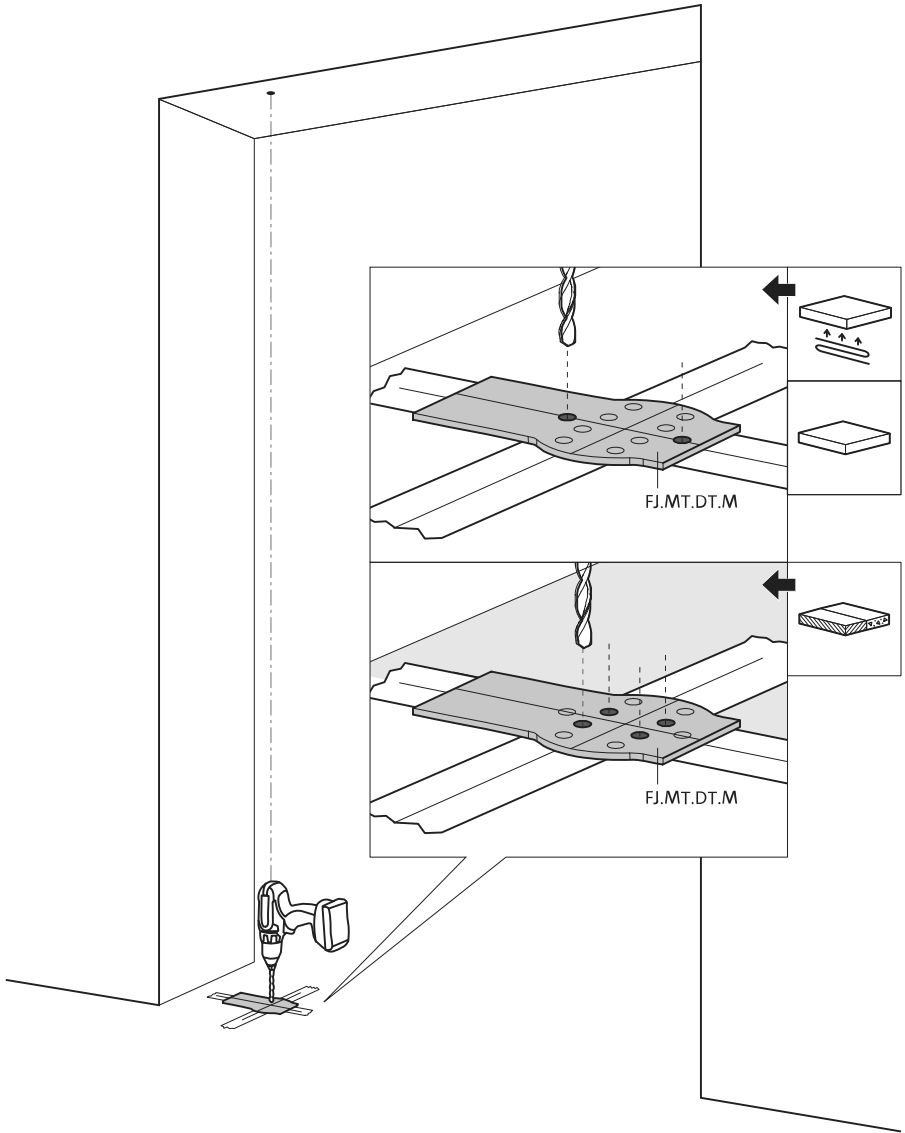

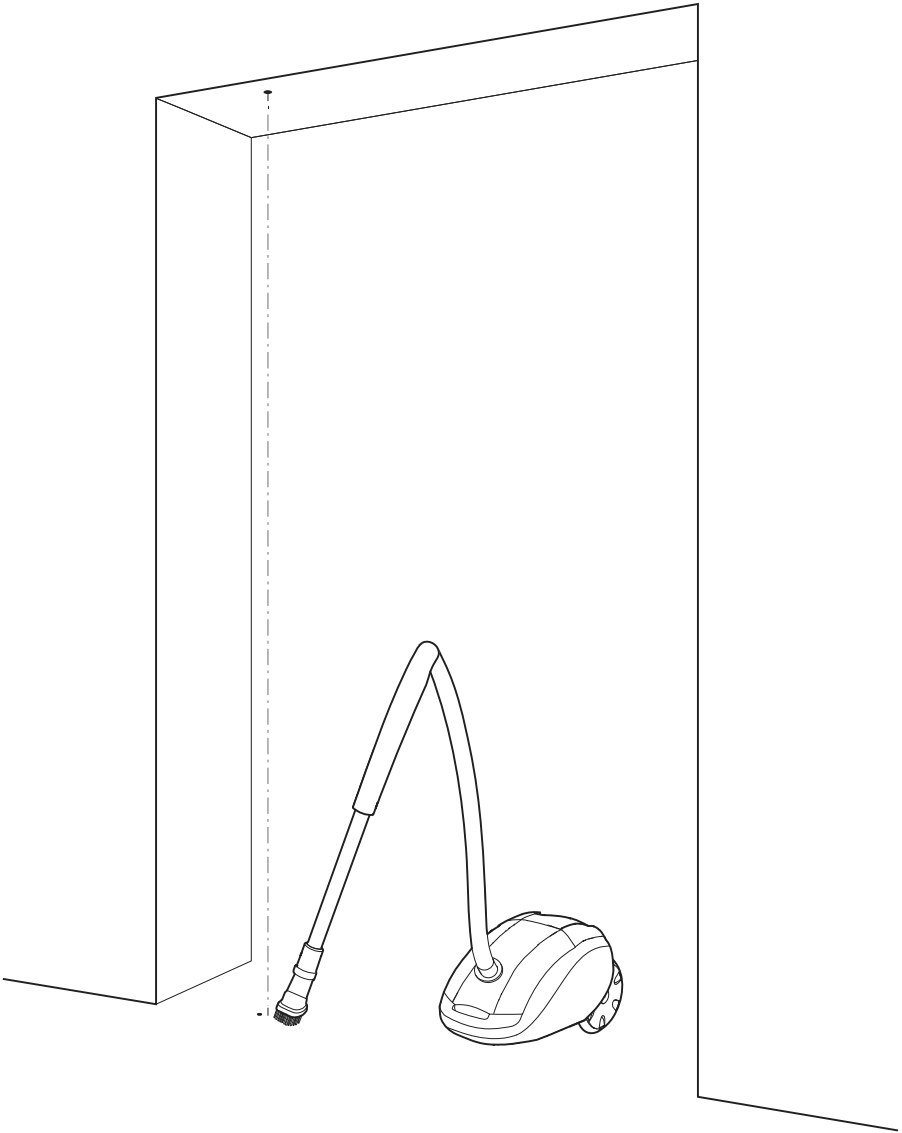



1

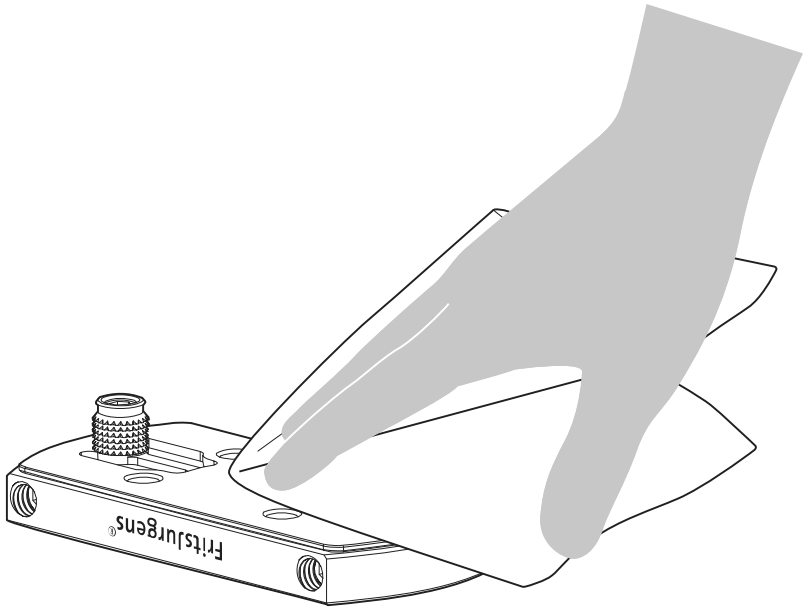

2

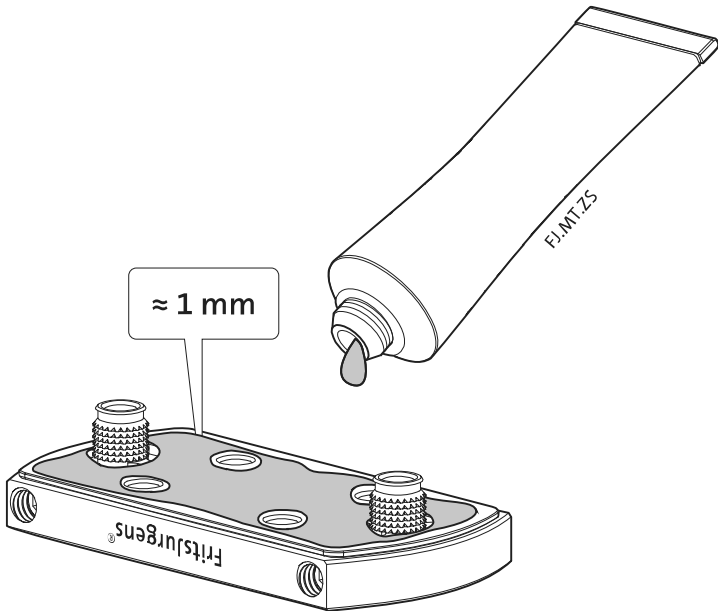

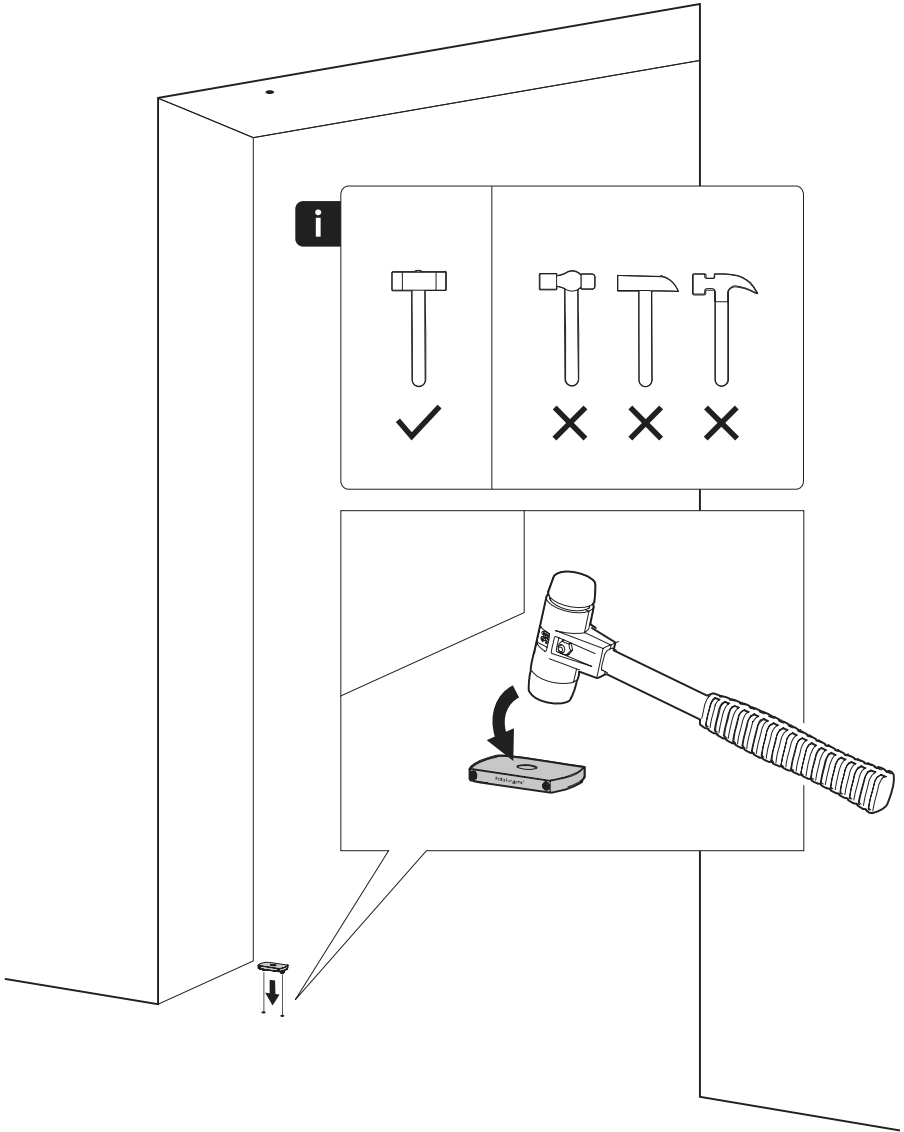

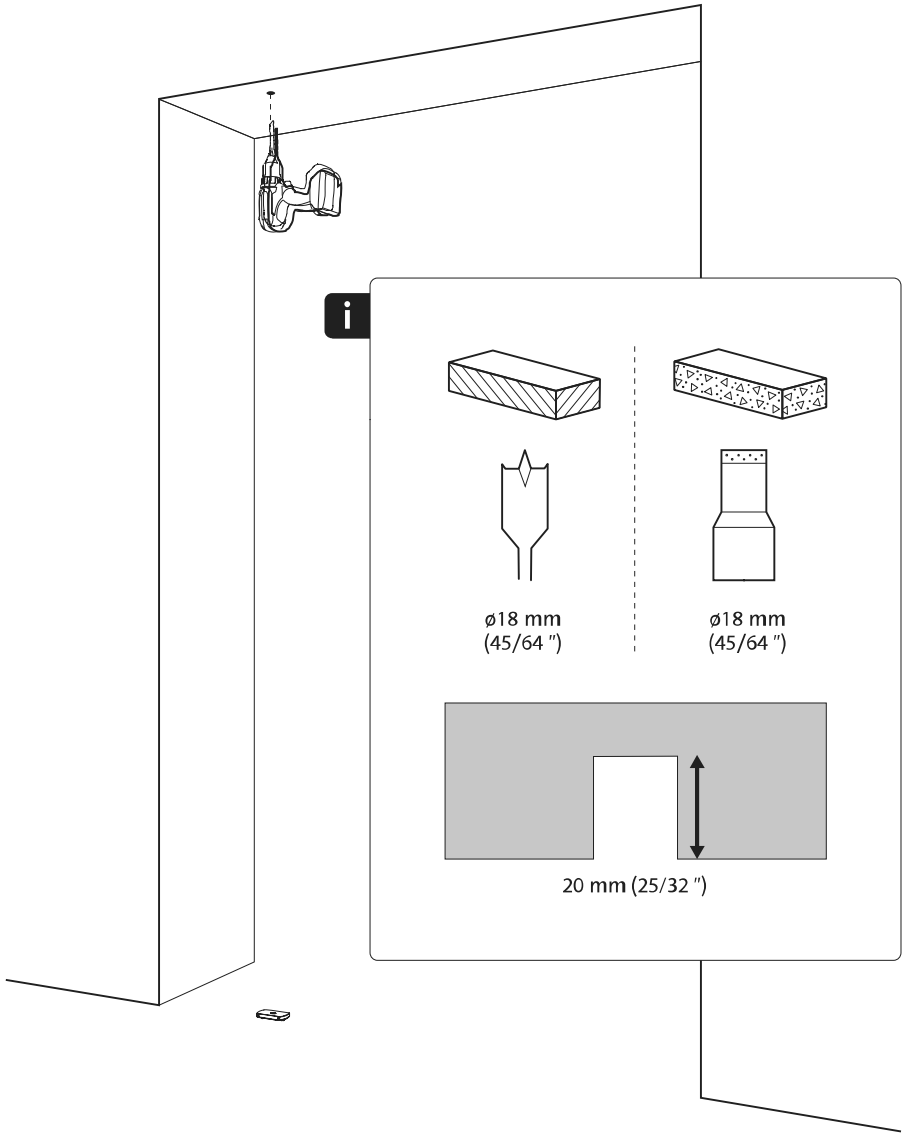
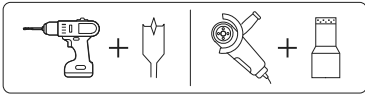



1

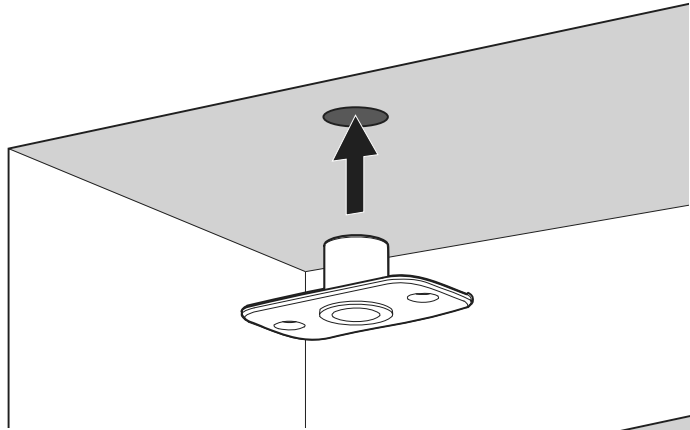

2

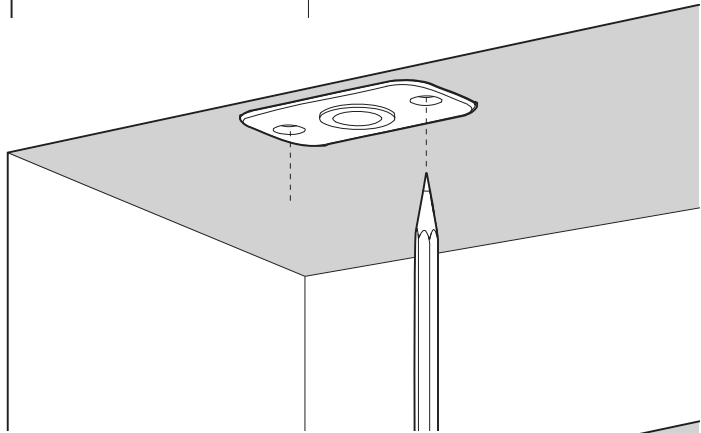

3

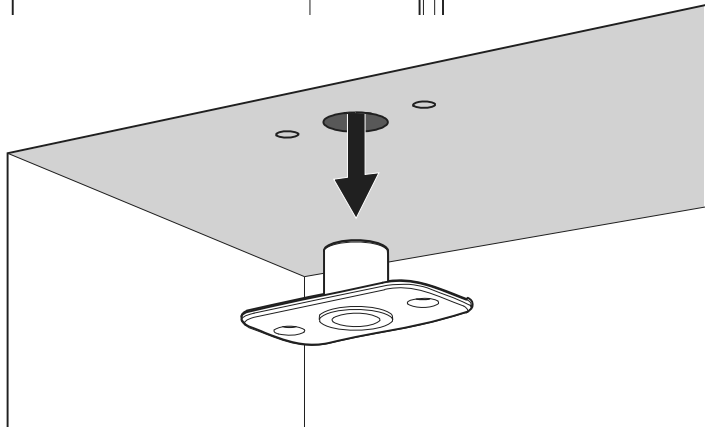



1

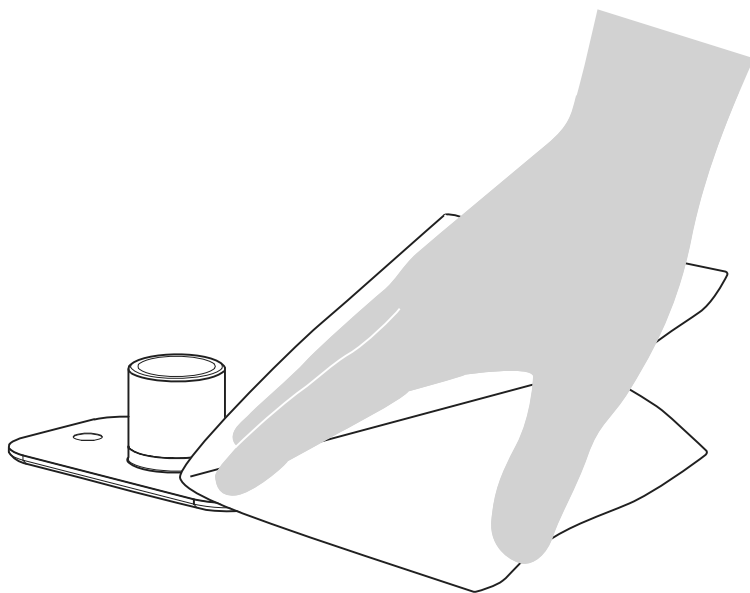

2

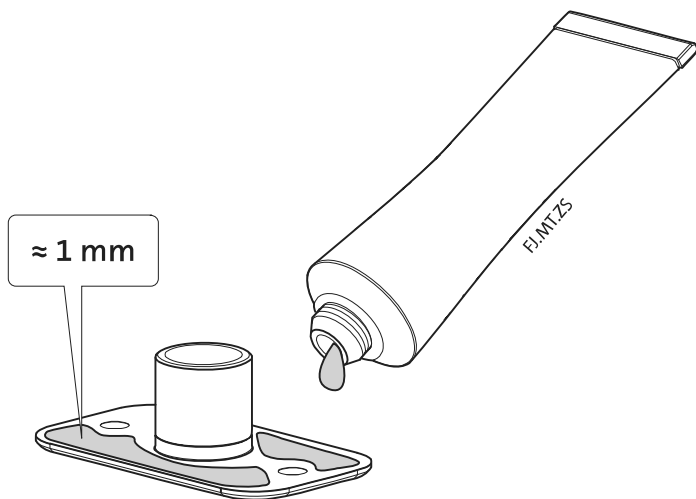

≈ 1 mm

FLIMITZS

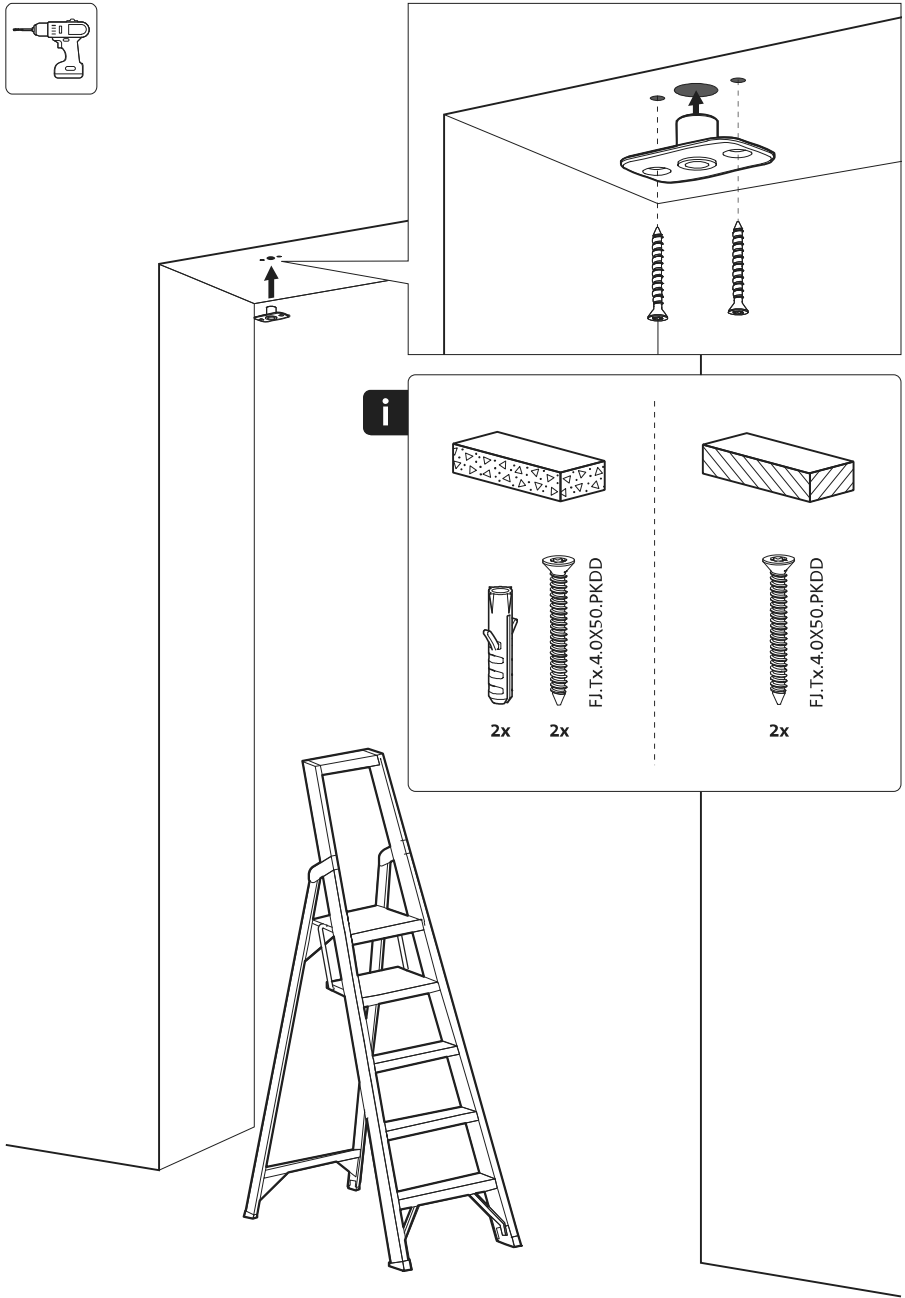

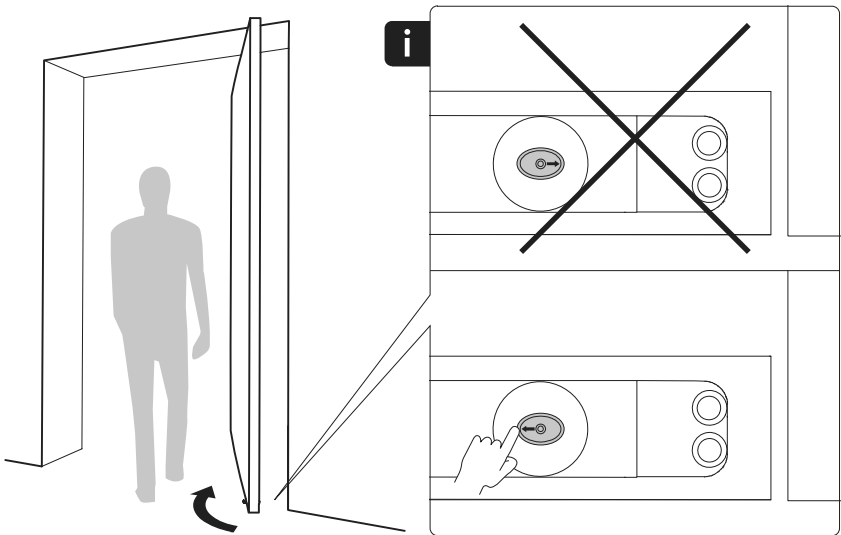
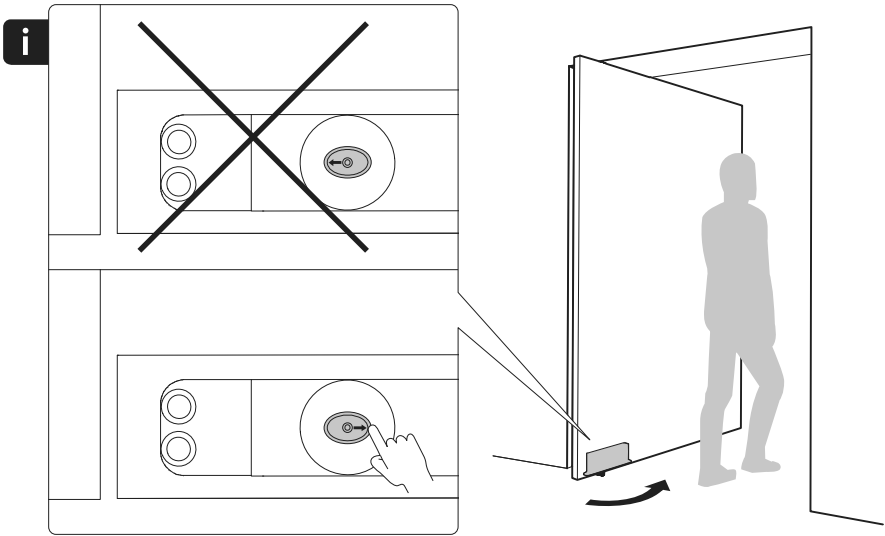

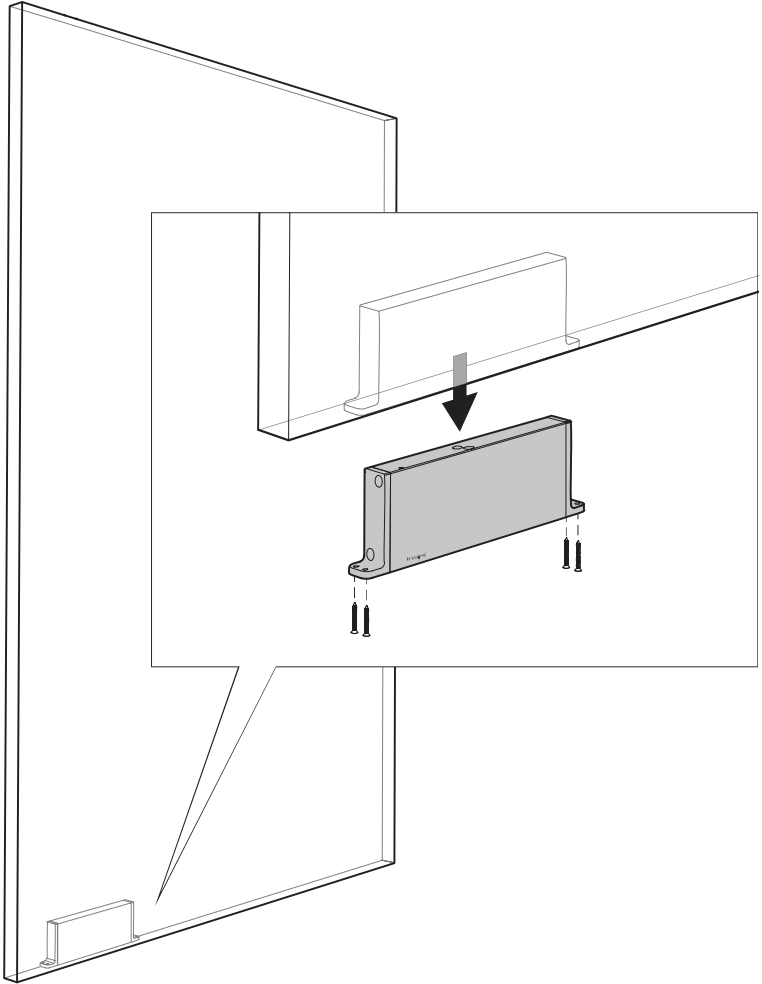

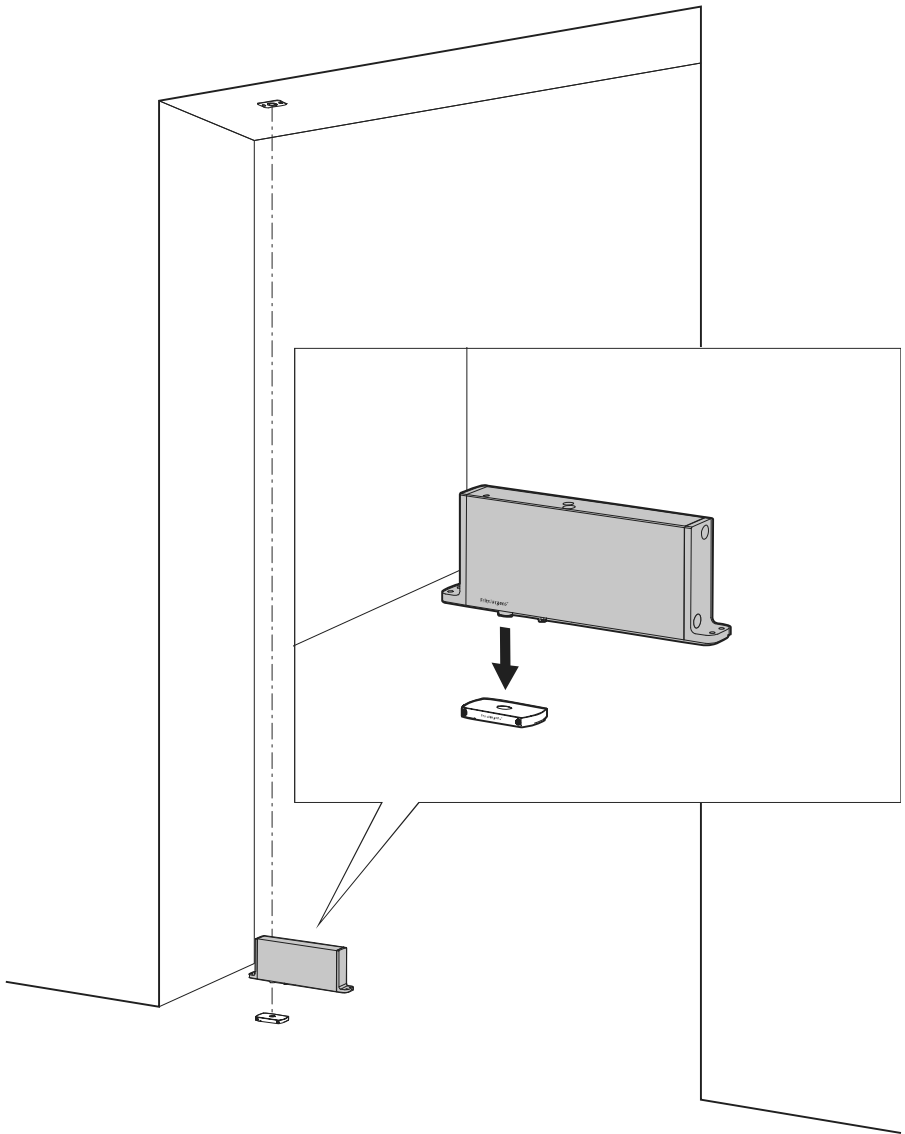

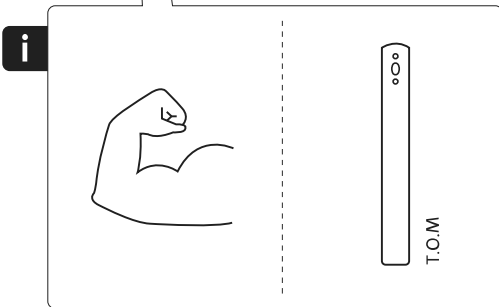
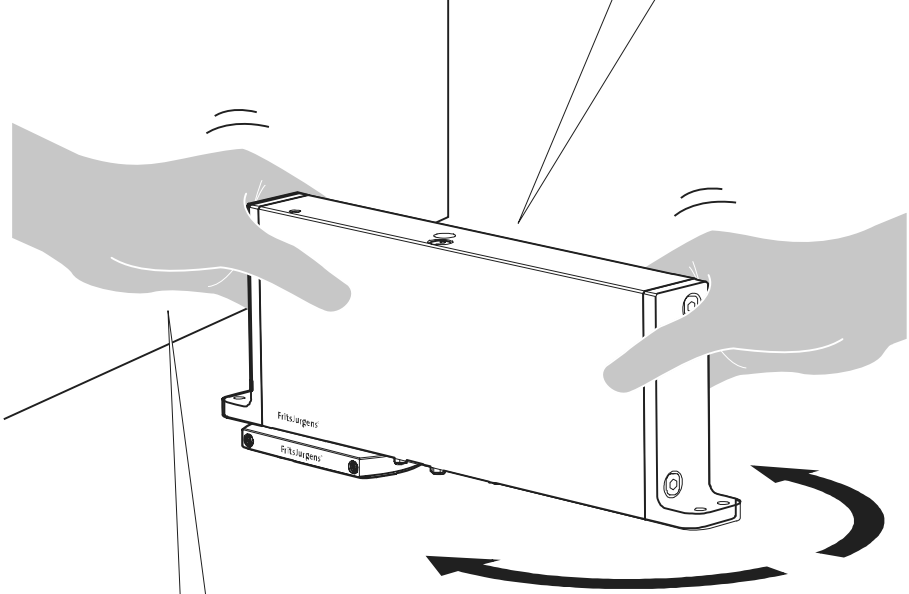
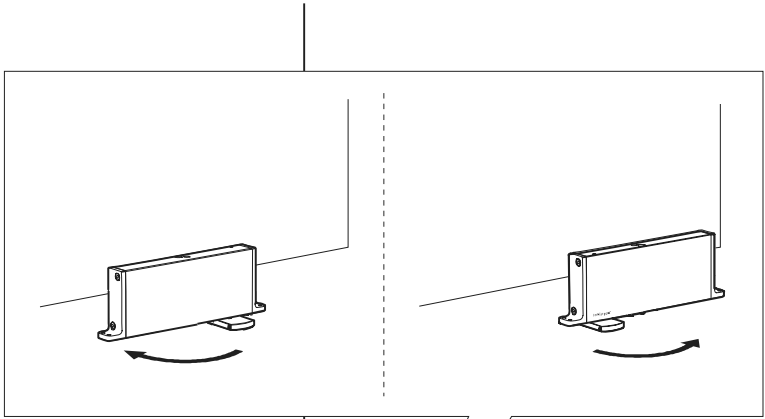

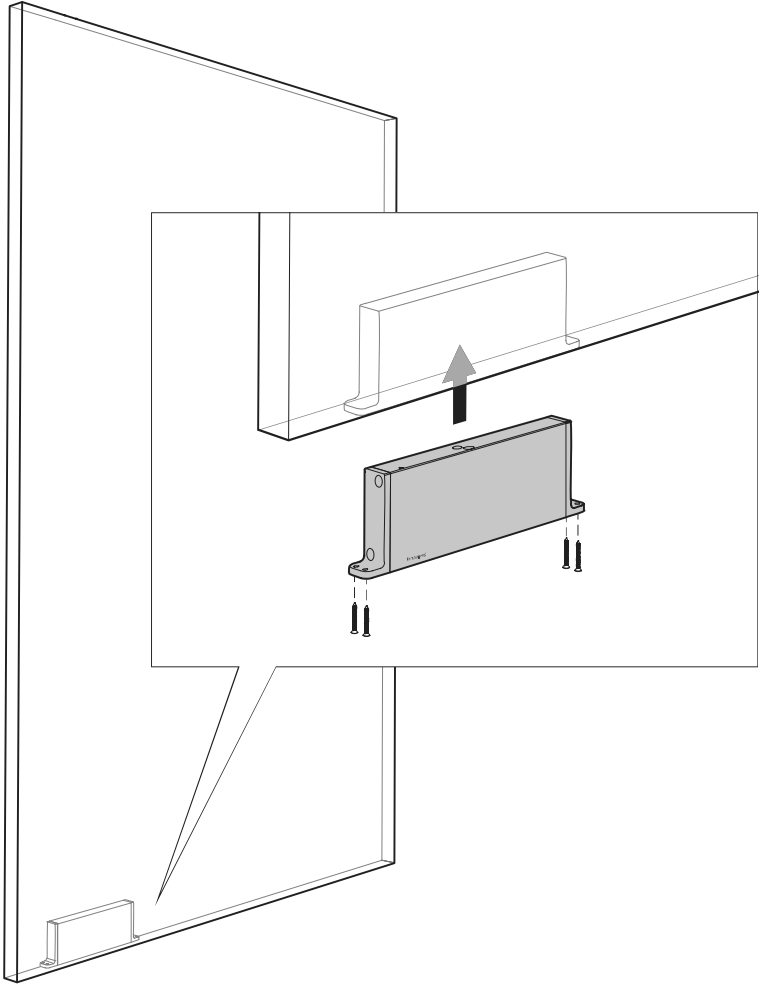

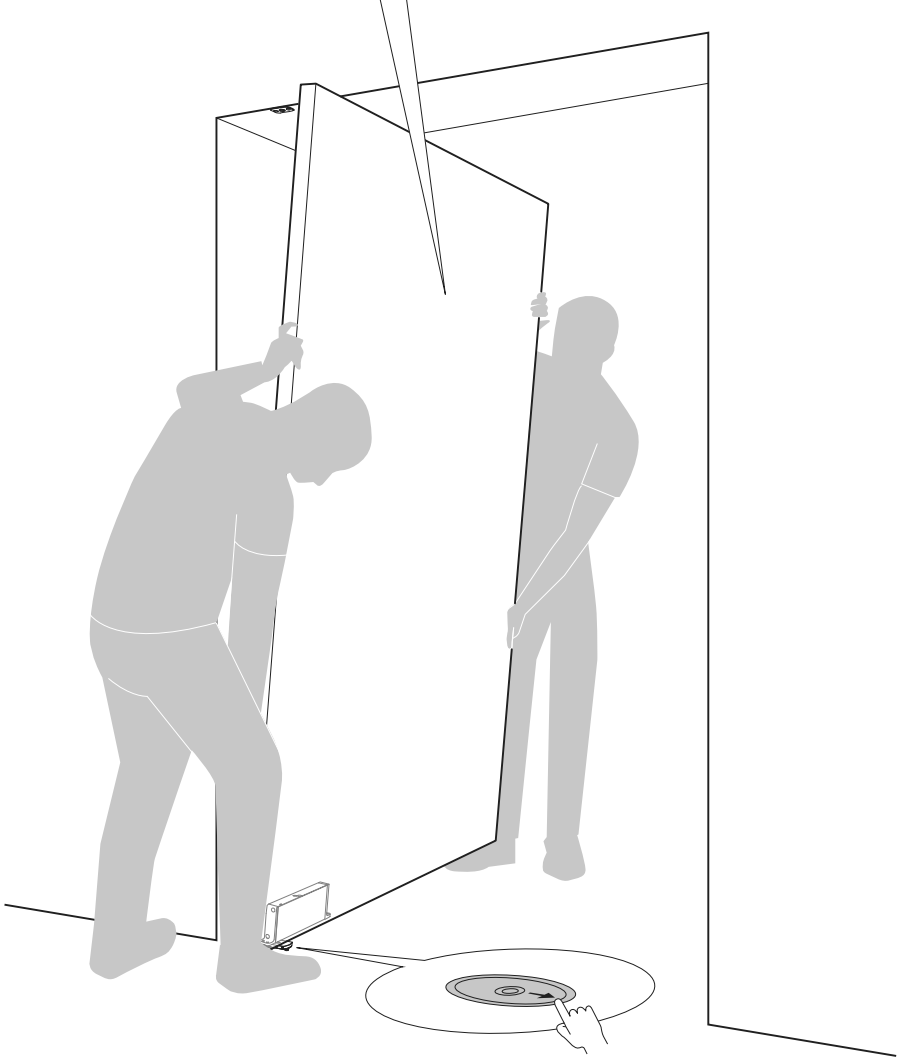
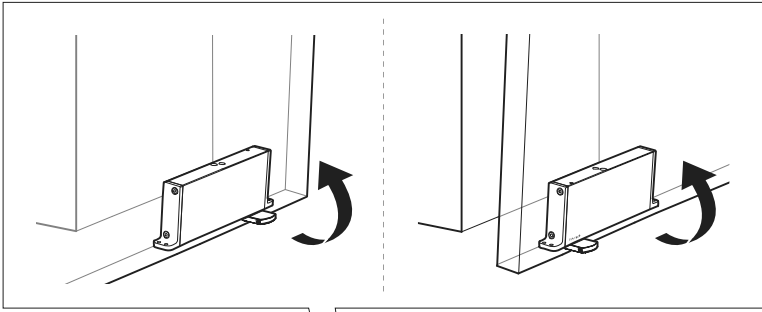

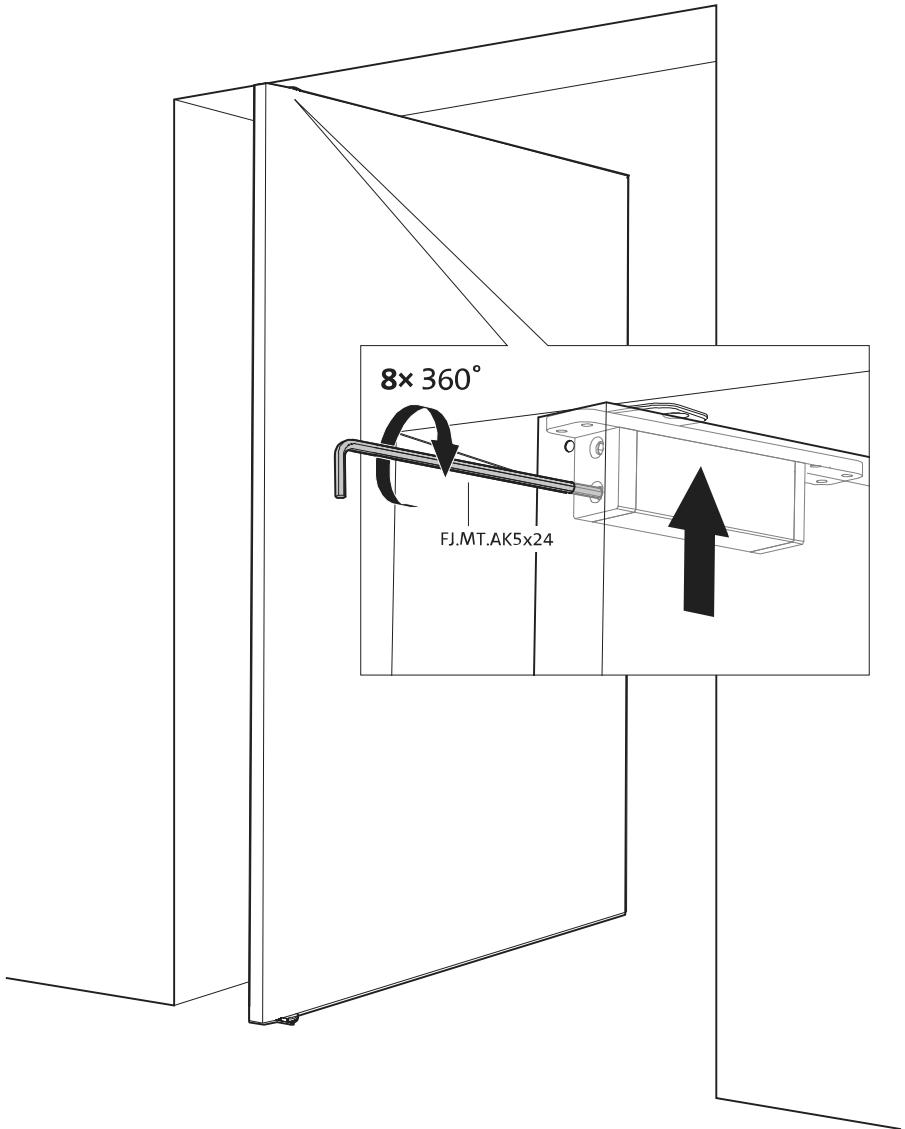
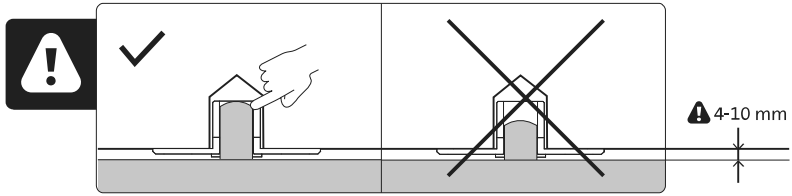

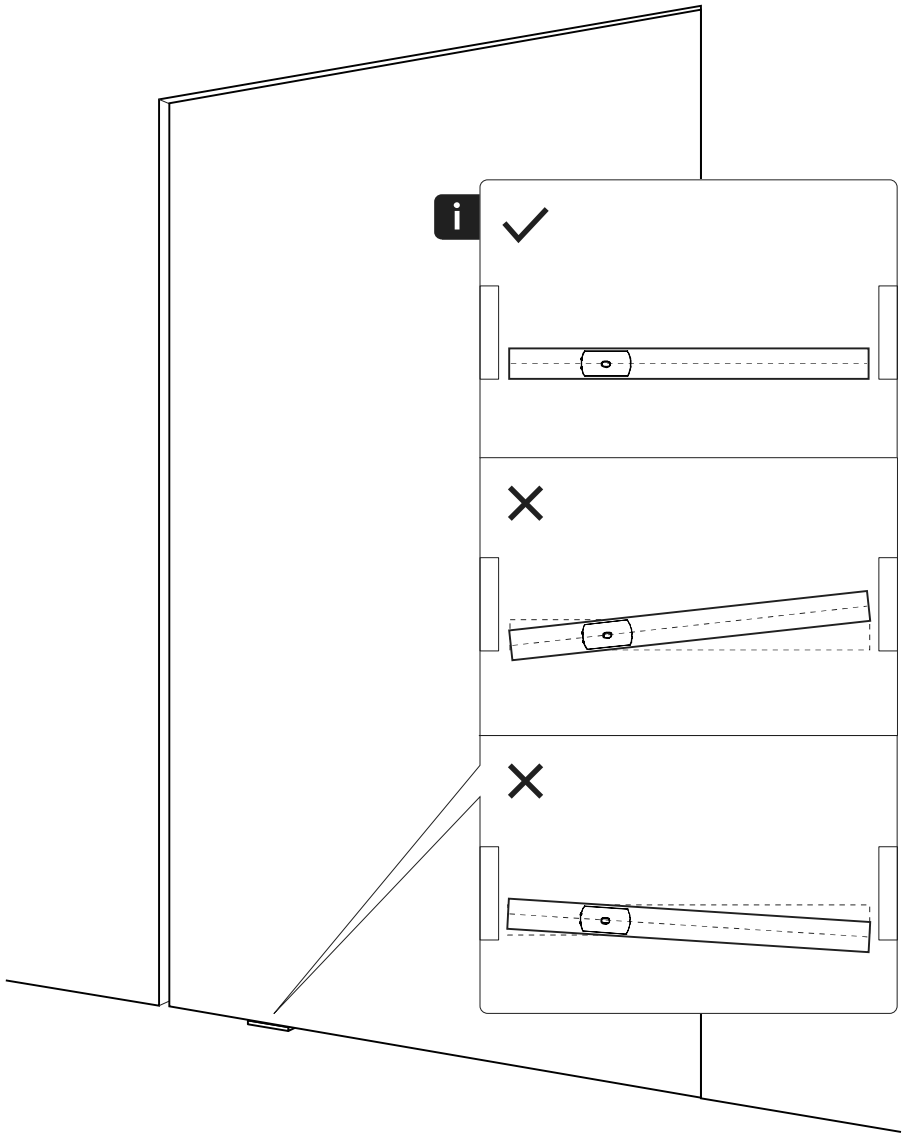

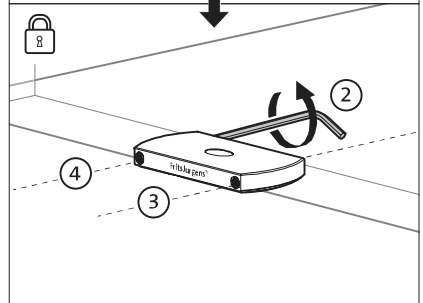
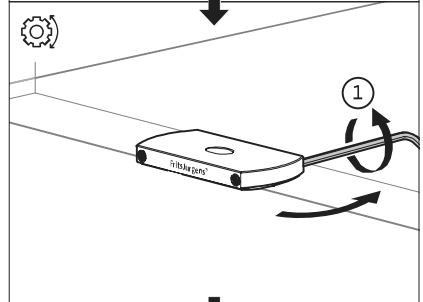
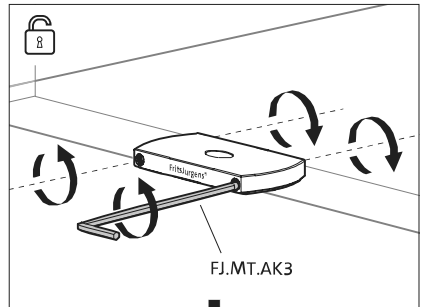
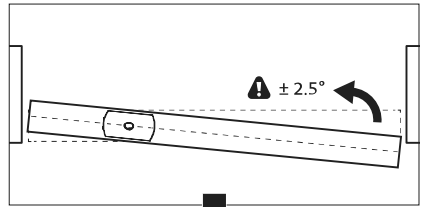
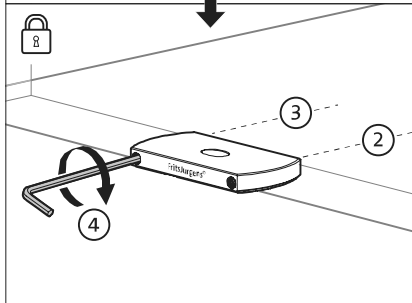
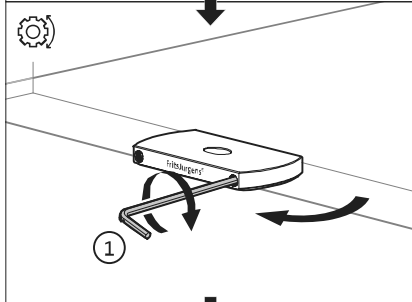
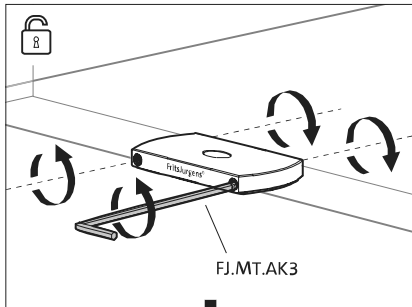
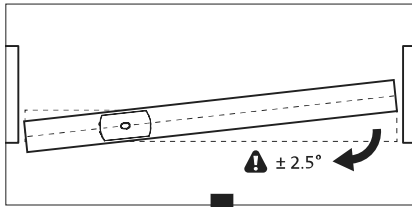

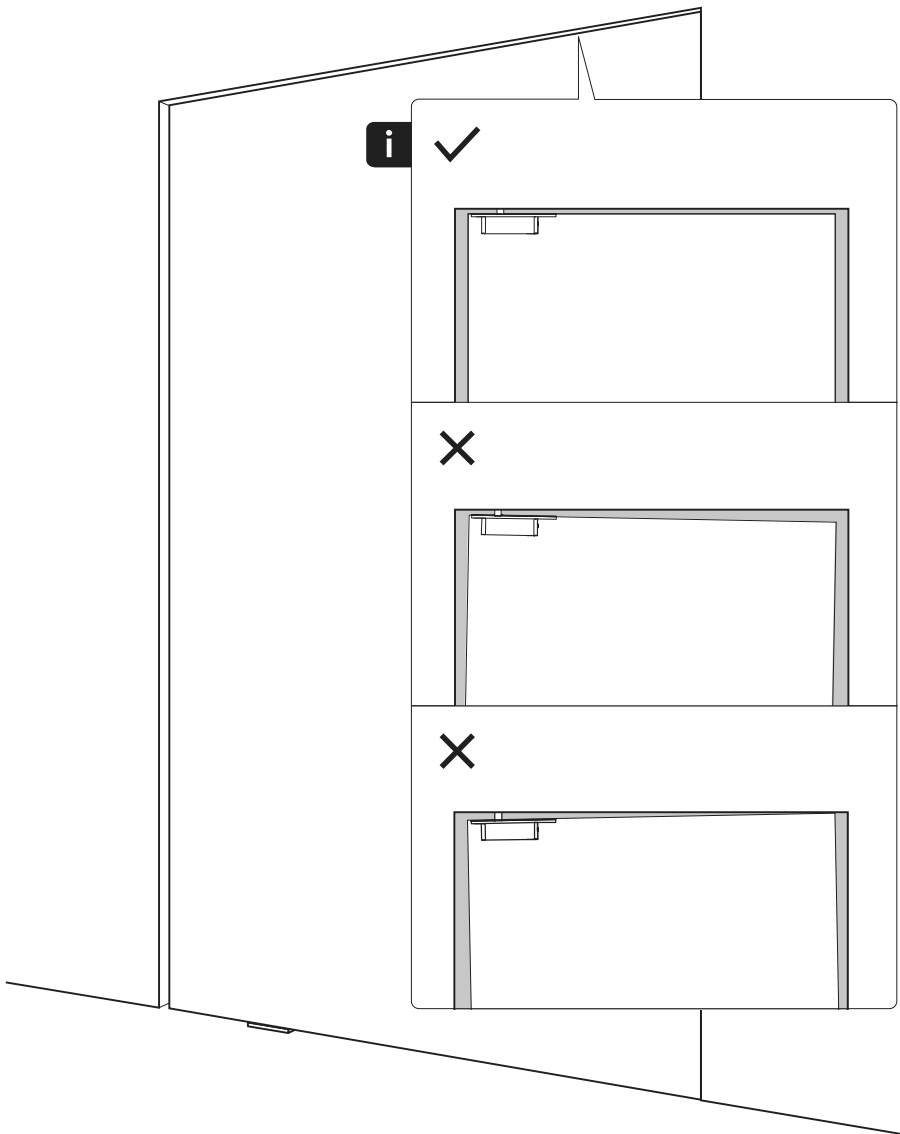

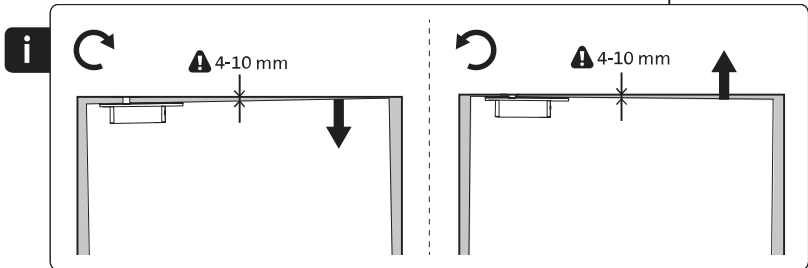
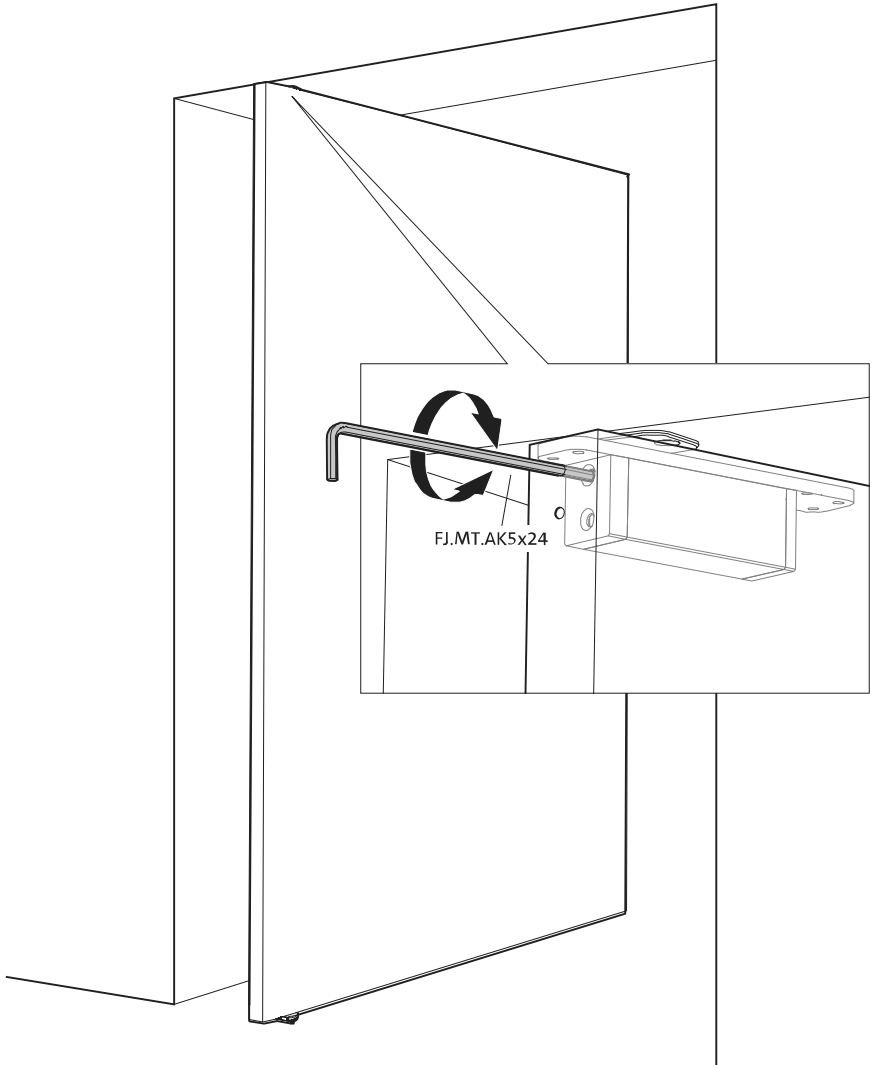

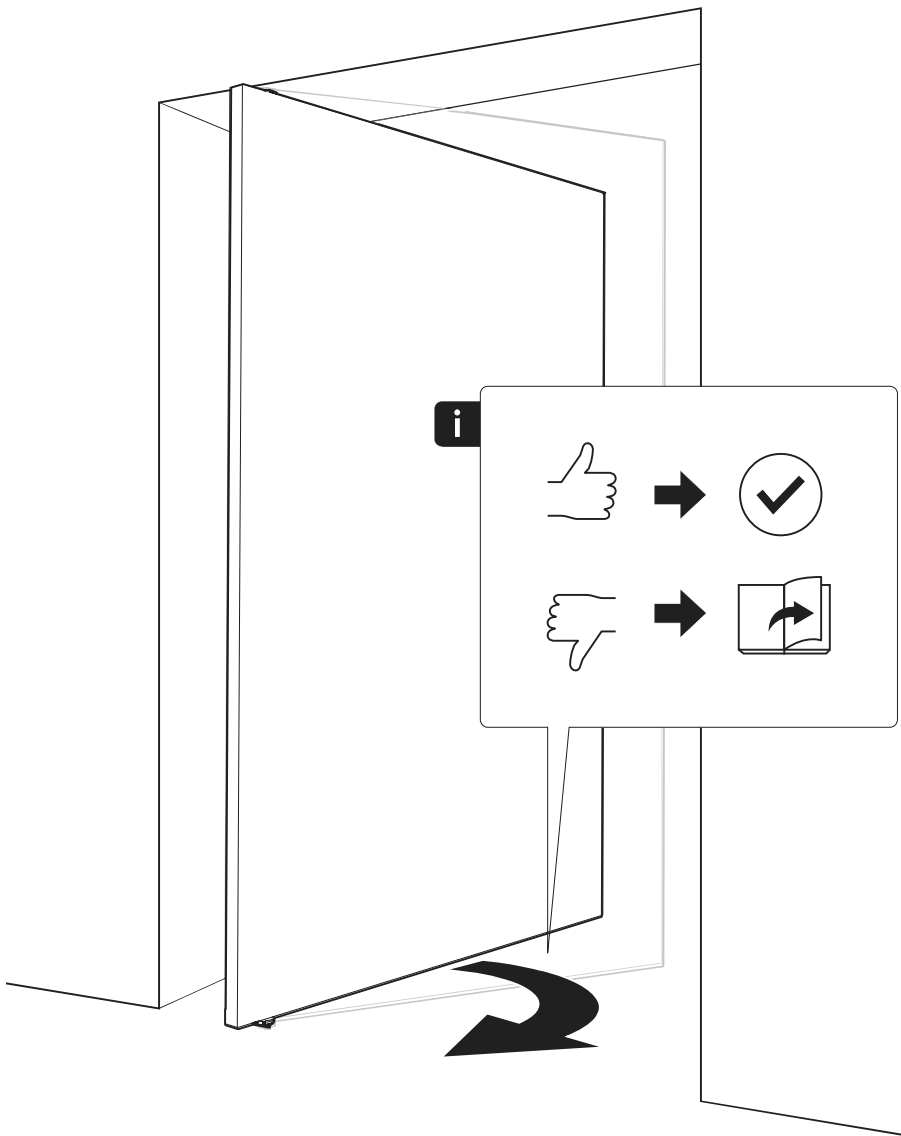

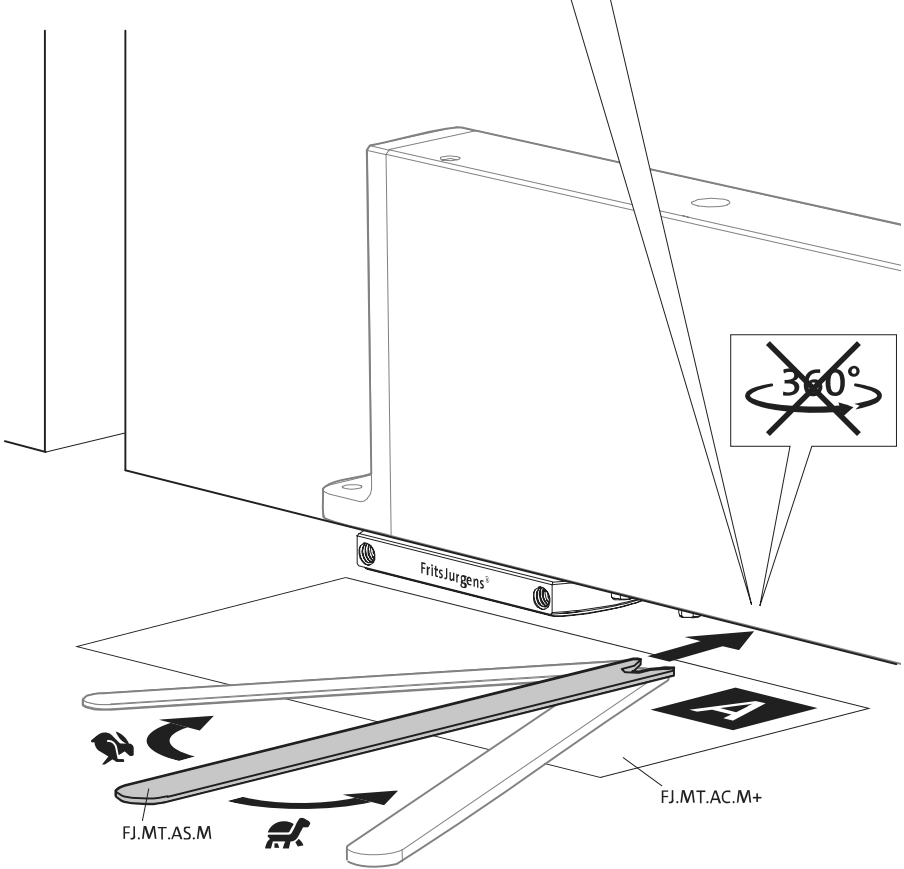
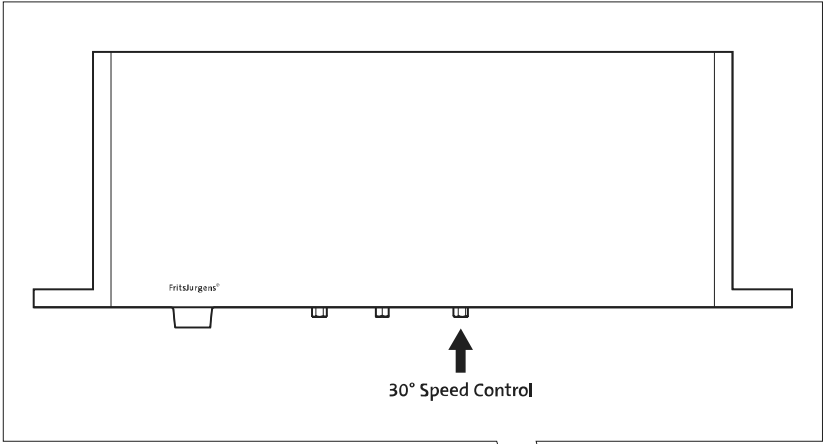

Demontageanleitung

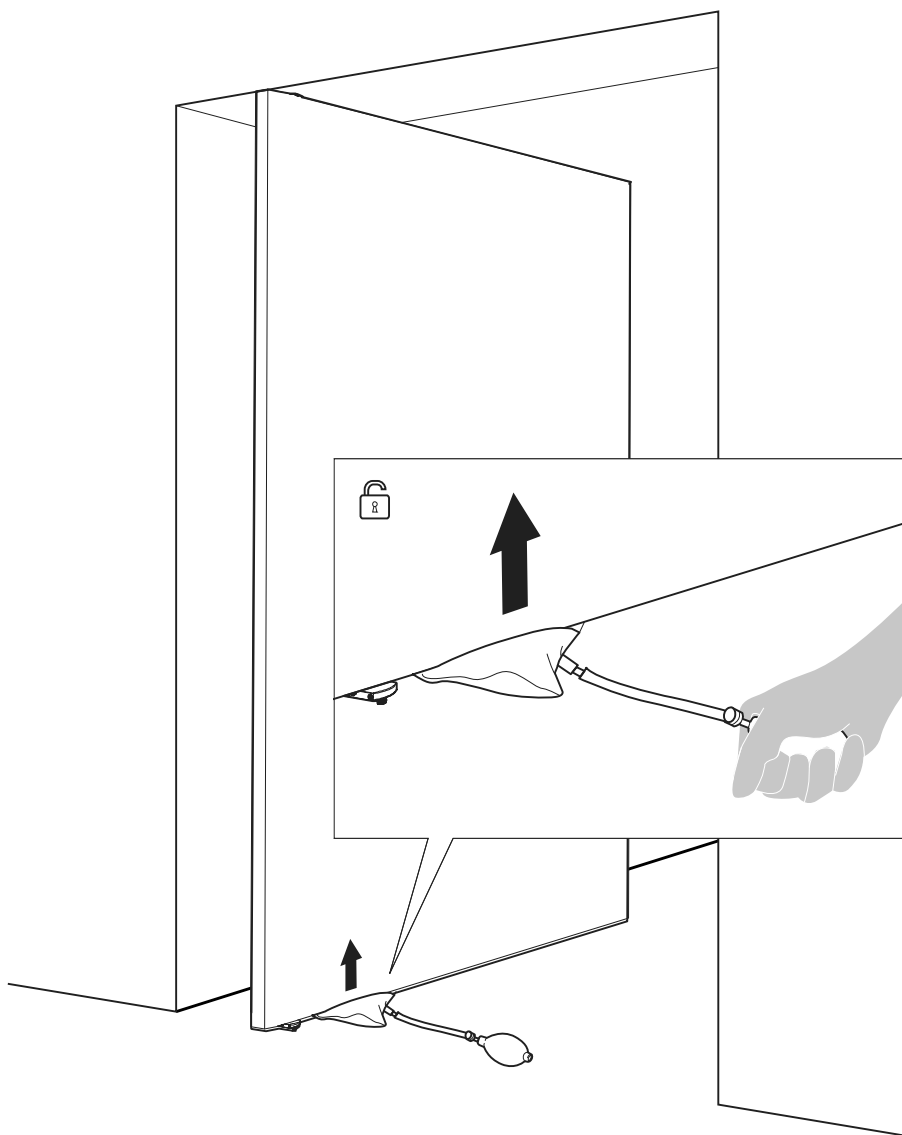

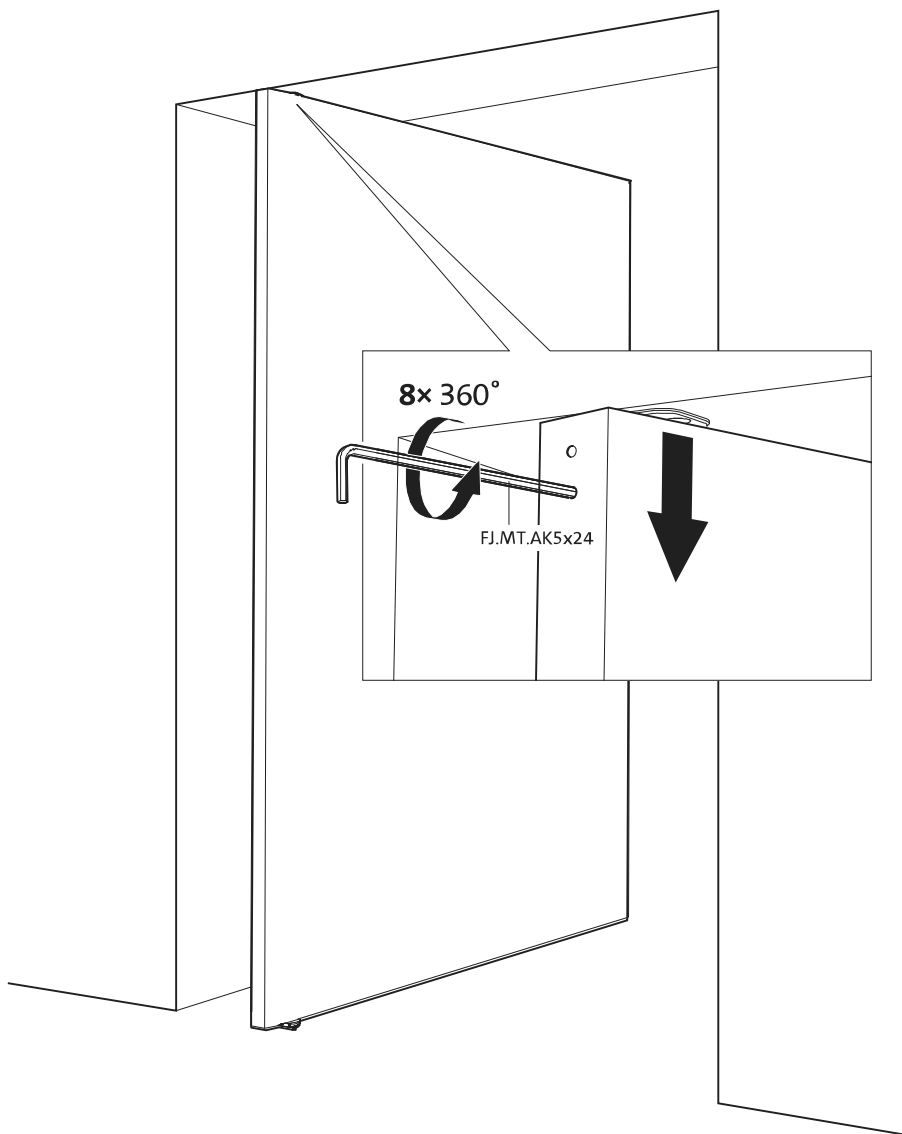

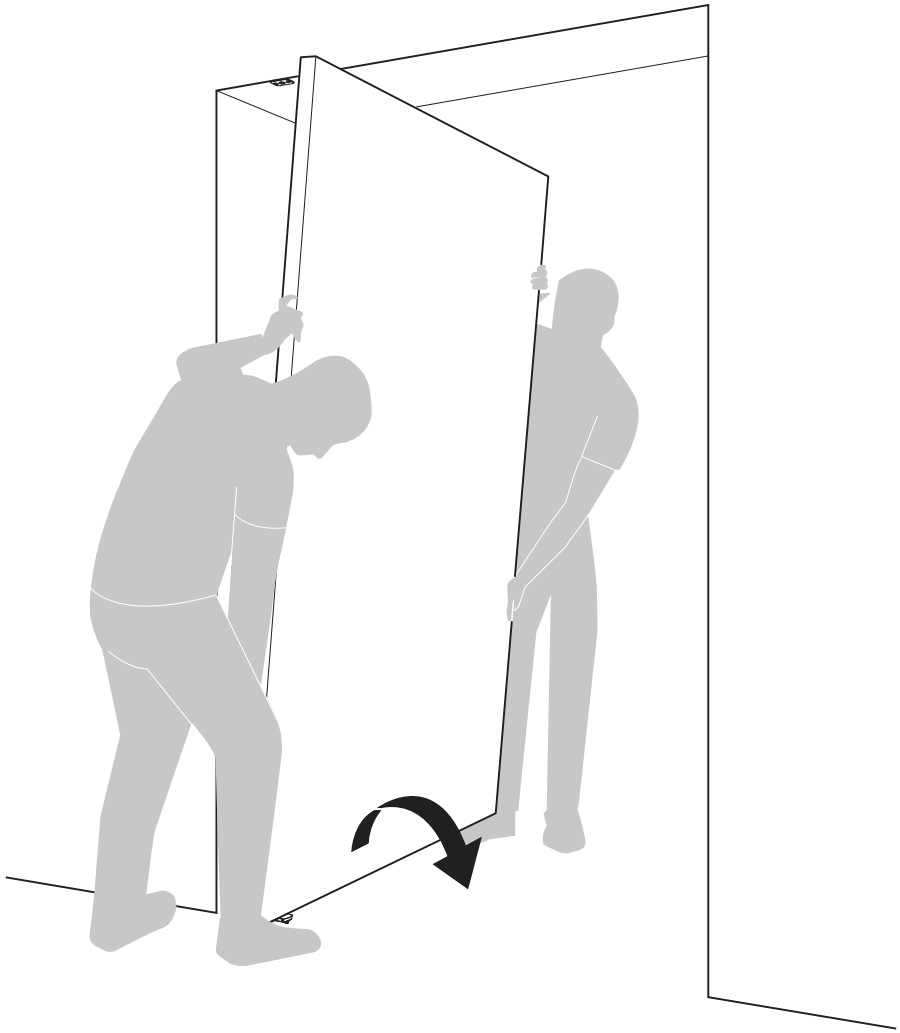

FritsJurgens International

A. Einsteinlaan 1
Die Niederlande
9615 TE Kolham
+31 598 343 410
info@fritsjurgens.com

FritsJurgens Dubai Branch

DLC-OP-A2-4-0029
Dubai South
Dubai
Vereinigte Arabische Emirate
+971 4 820 8106
+971 58 137 2611
dubai@fritsjurgens.com
fritsjurgens.com

Copyright © FritsJurgens®
B.P.M.70.C.X.XX



