

System 3

Milling and mounting manual

FritsJurgens Set - 70 mm Class G - invisible

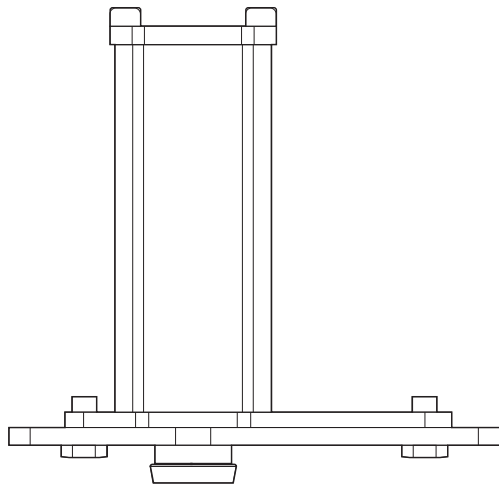

FritsJurgens®

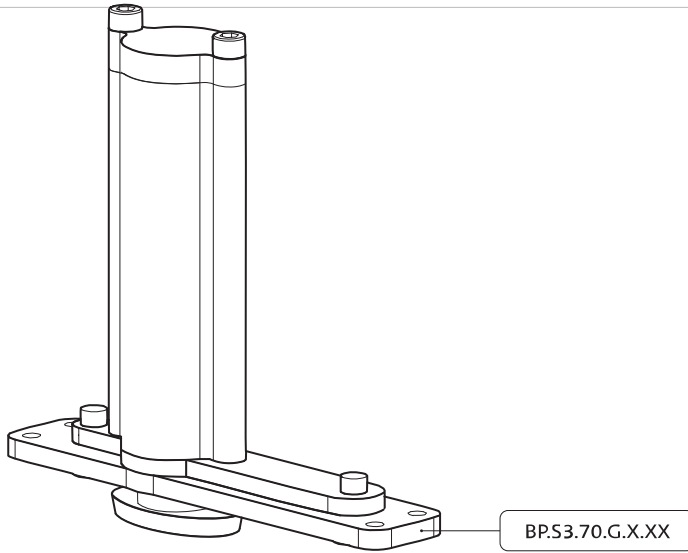

Milling instructions

BP.S3.70.G.X.XX

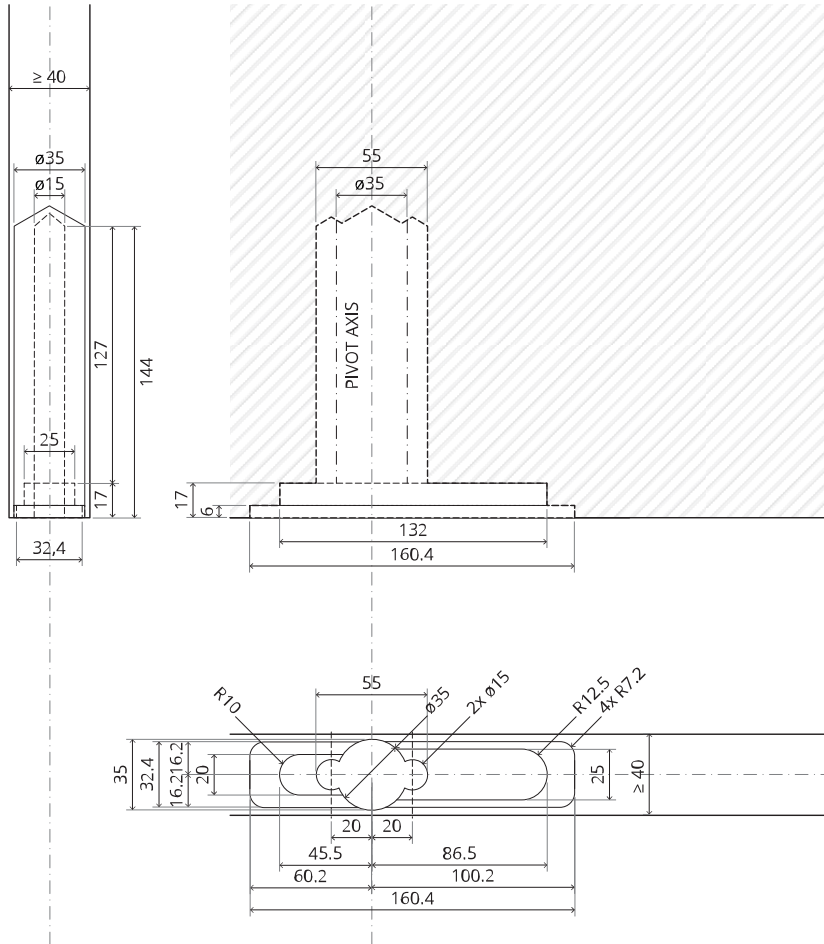

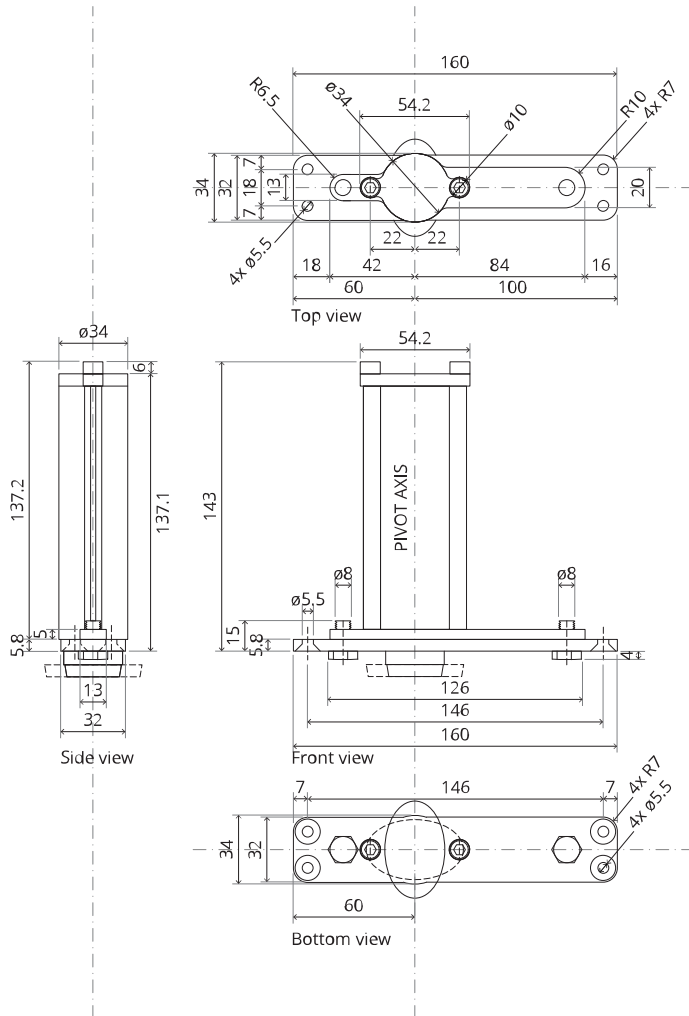

TP.X.70.G.X.XX

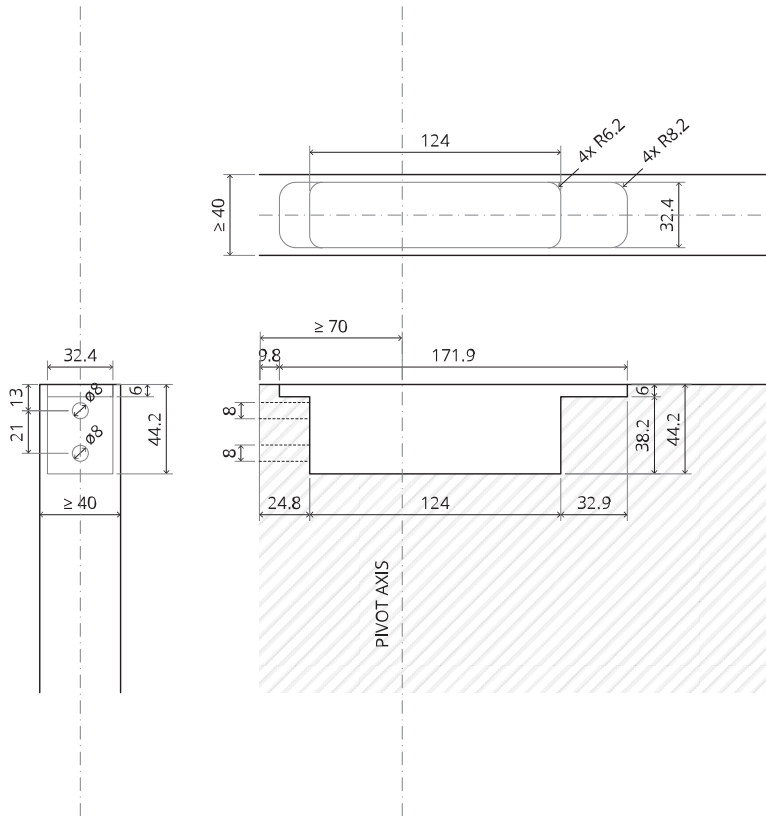

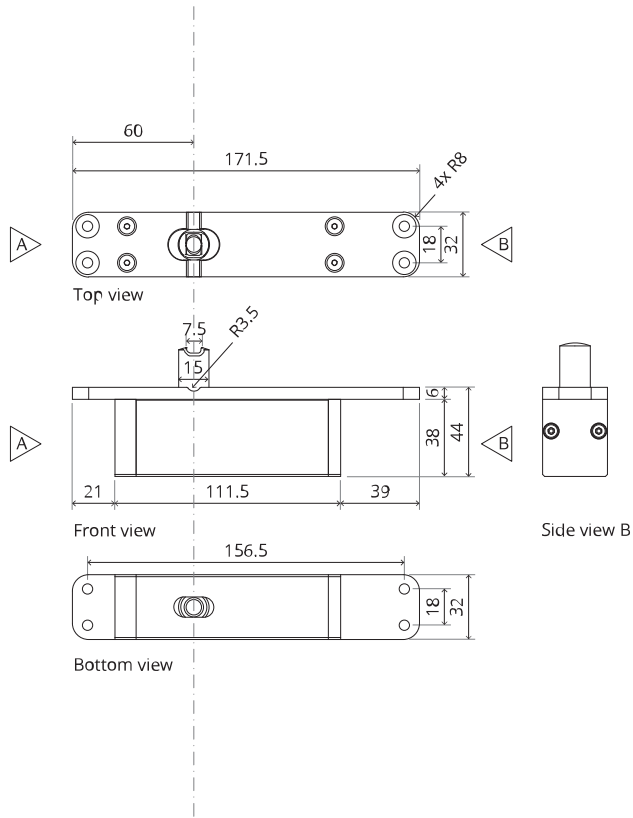
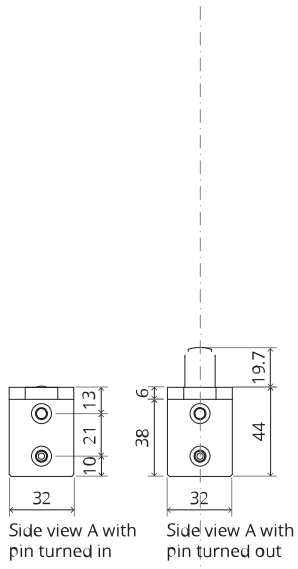

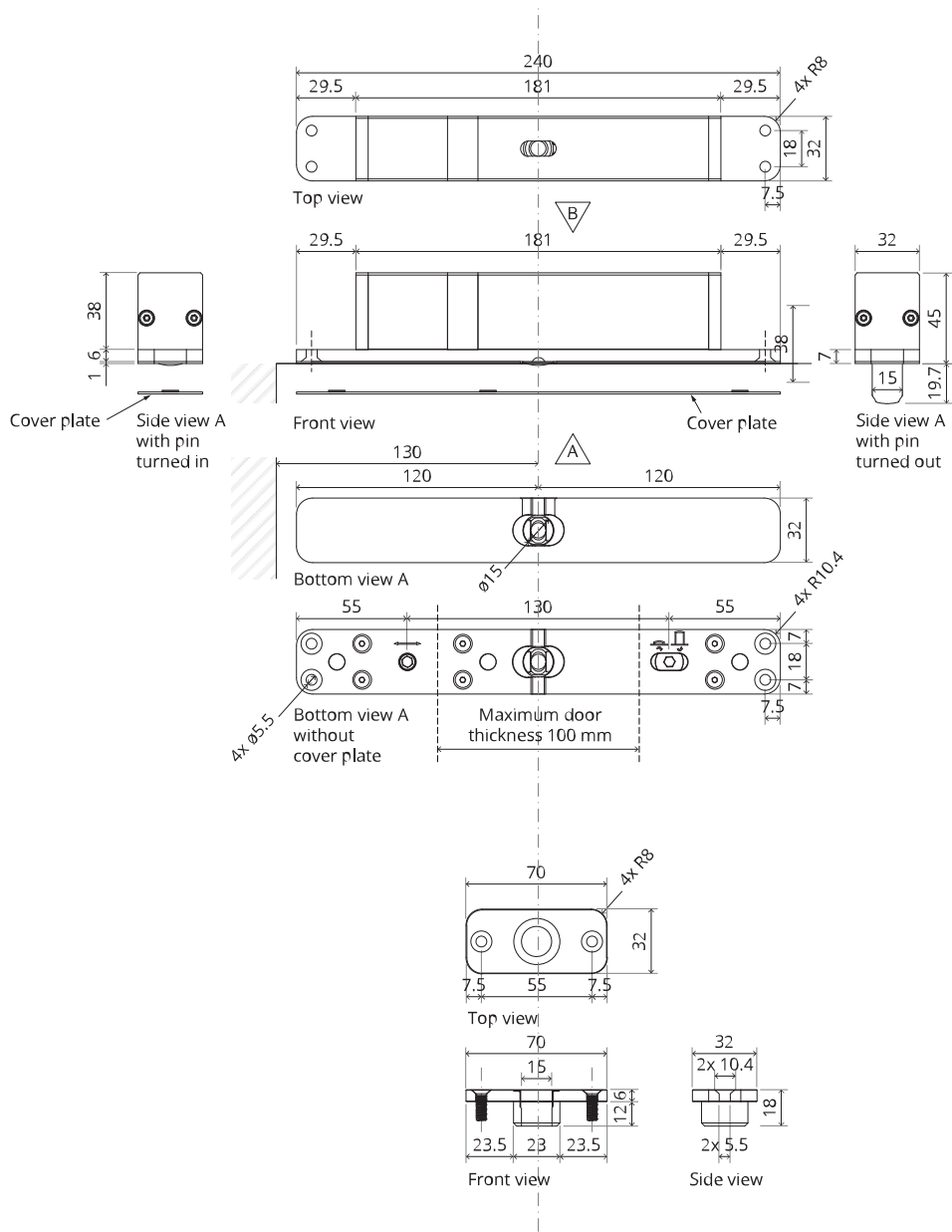

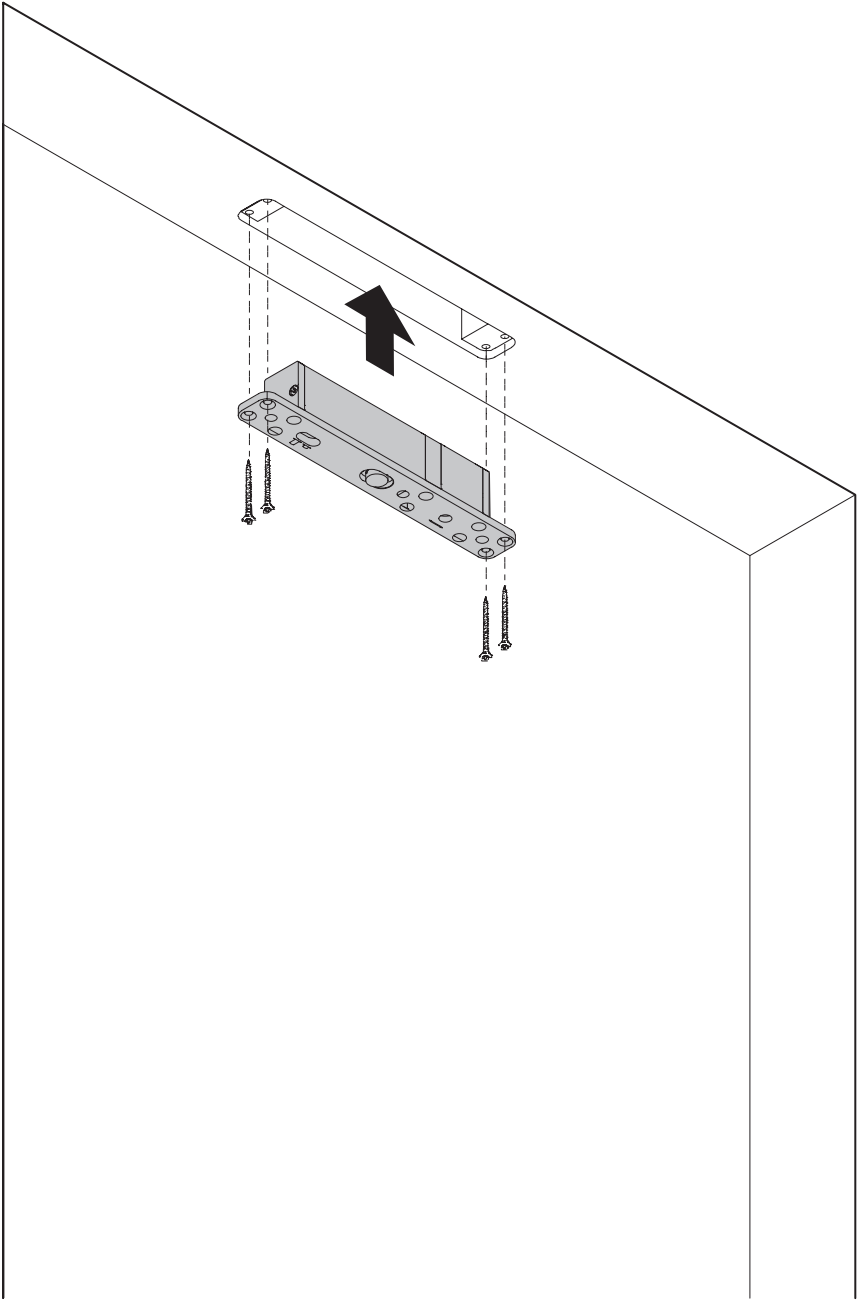

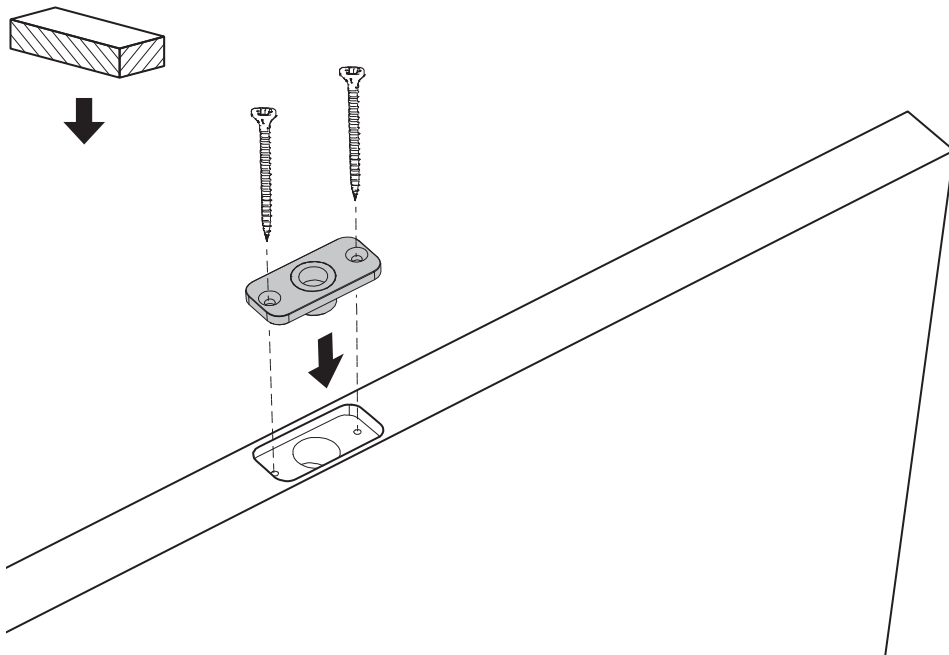
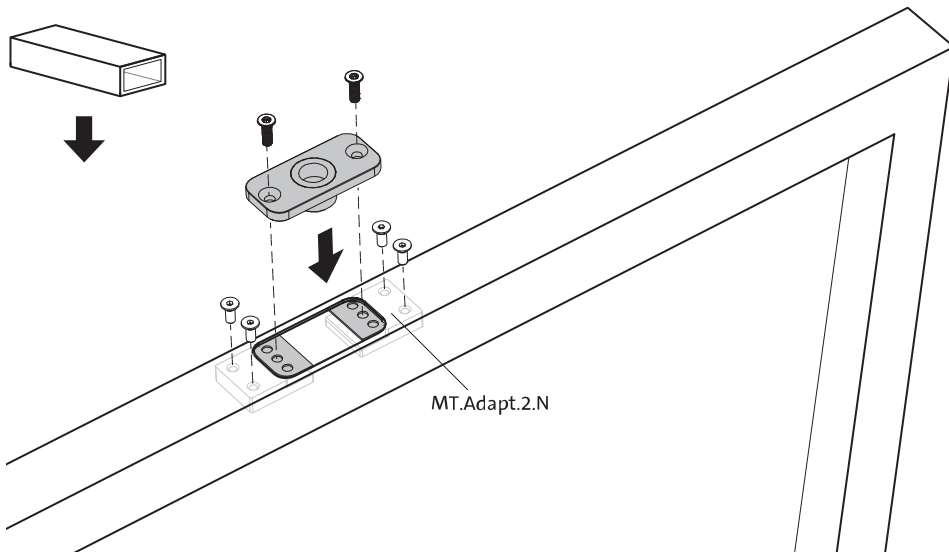

Mounting instructions

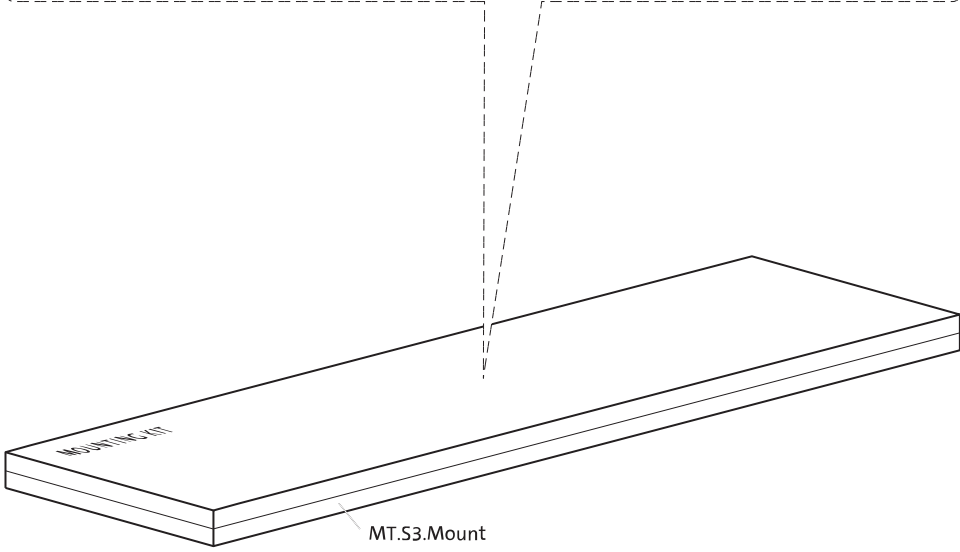
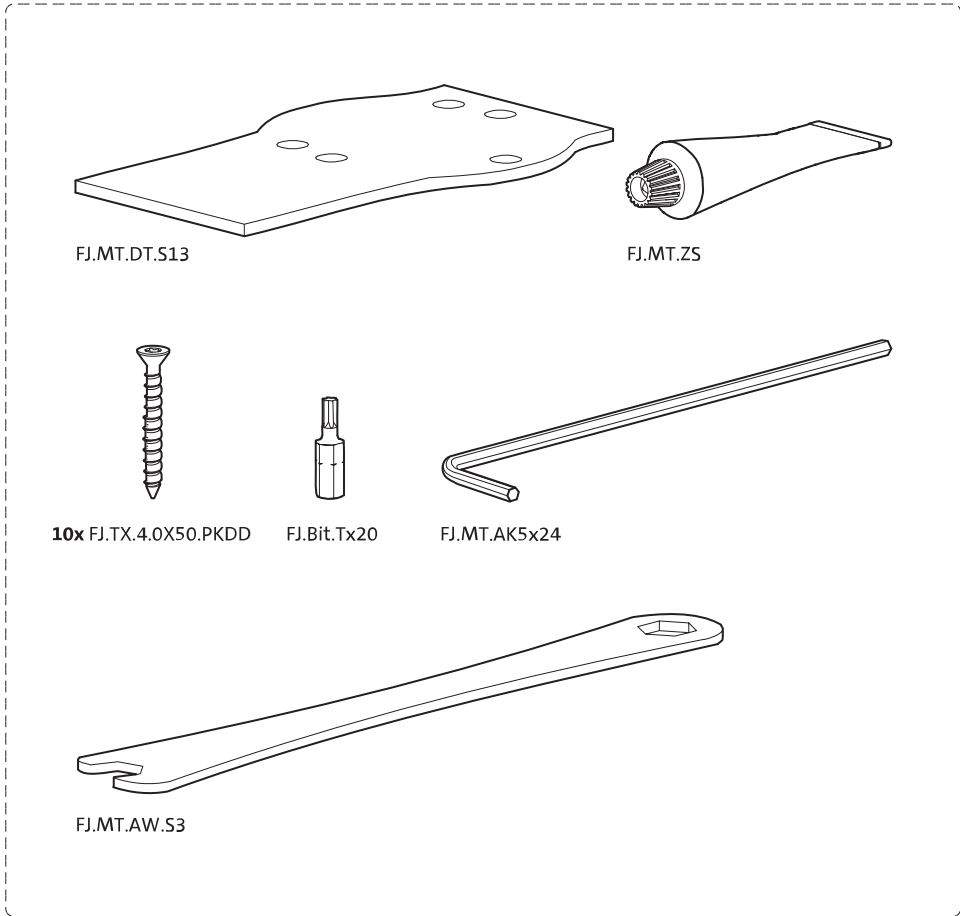

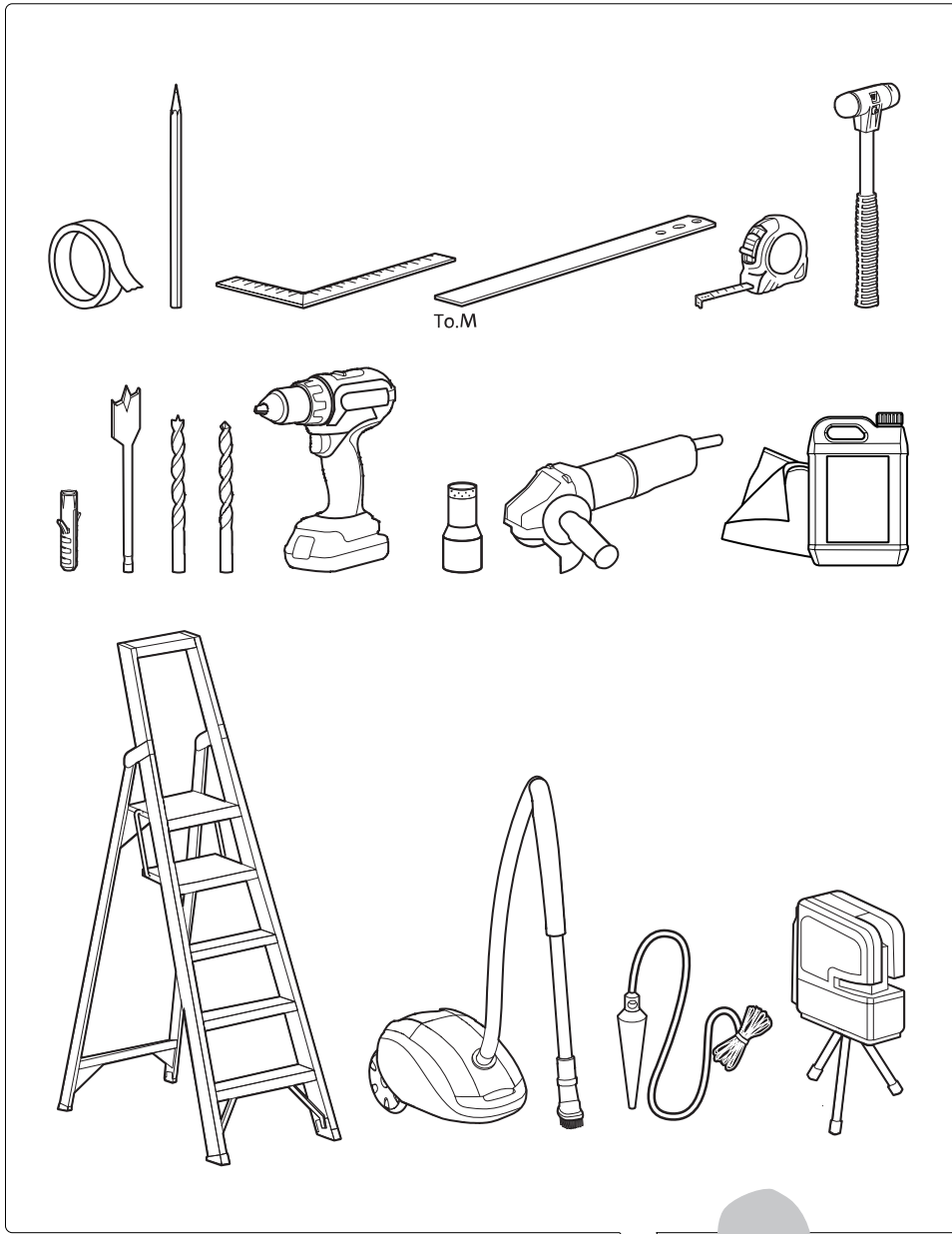

To.M

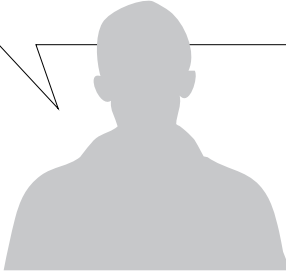

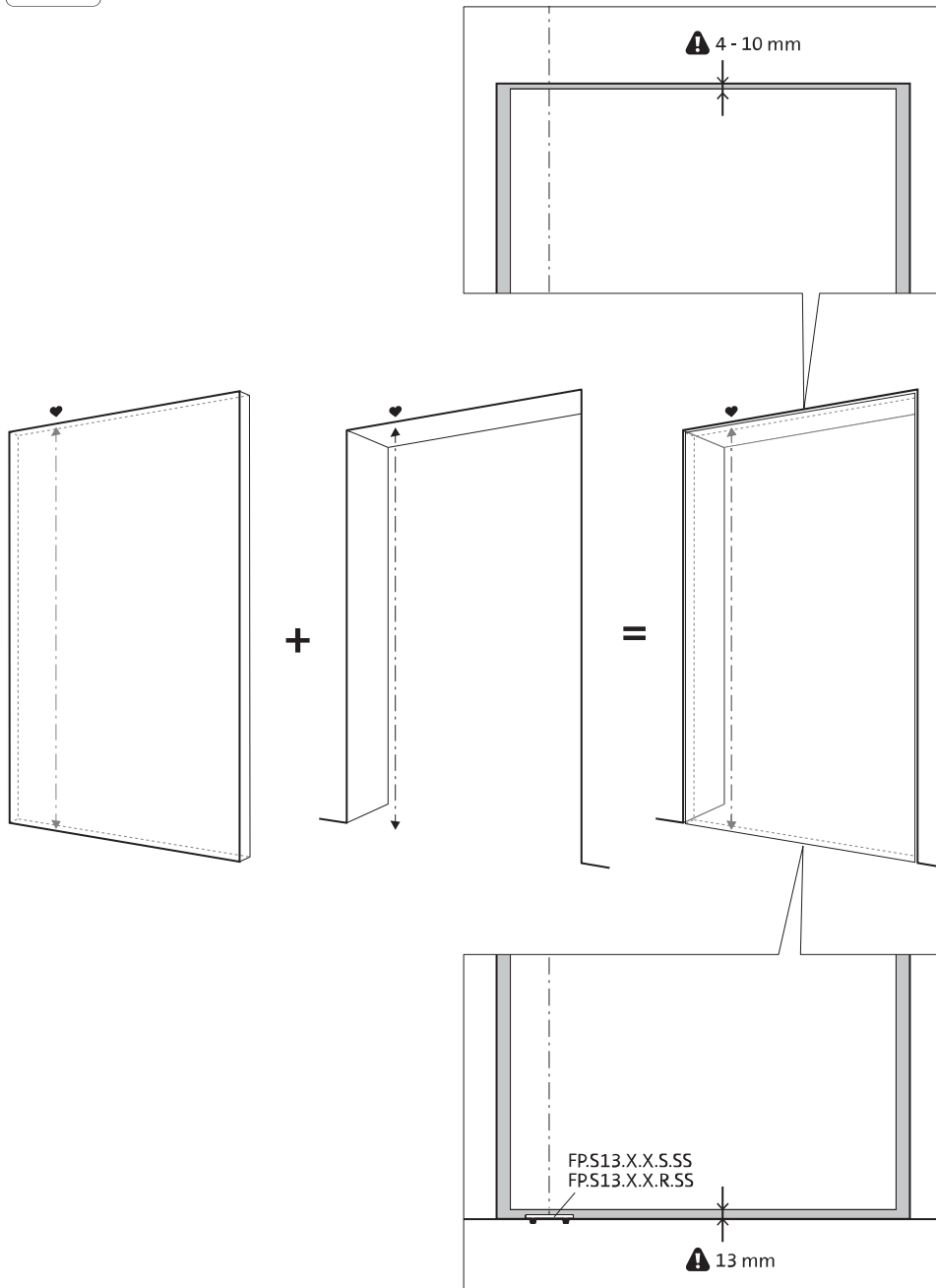

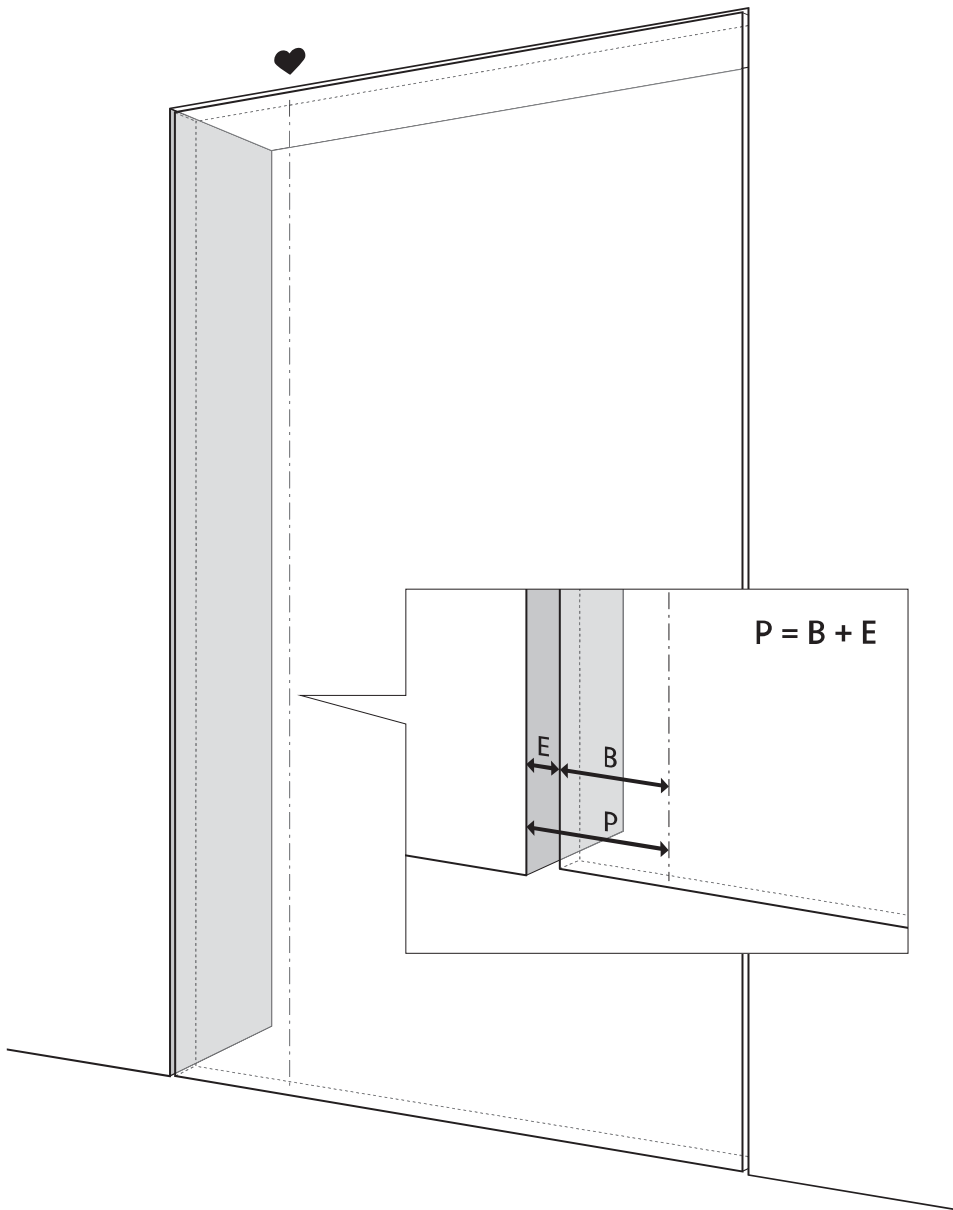

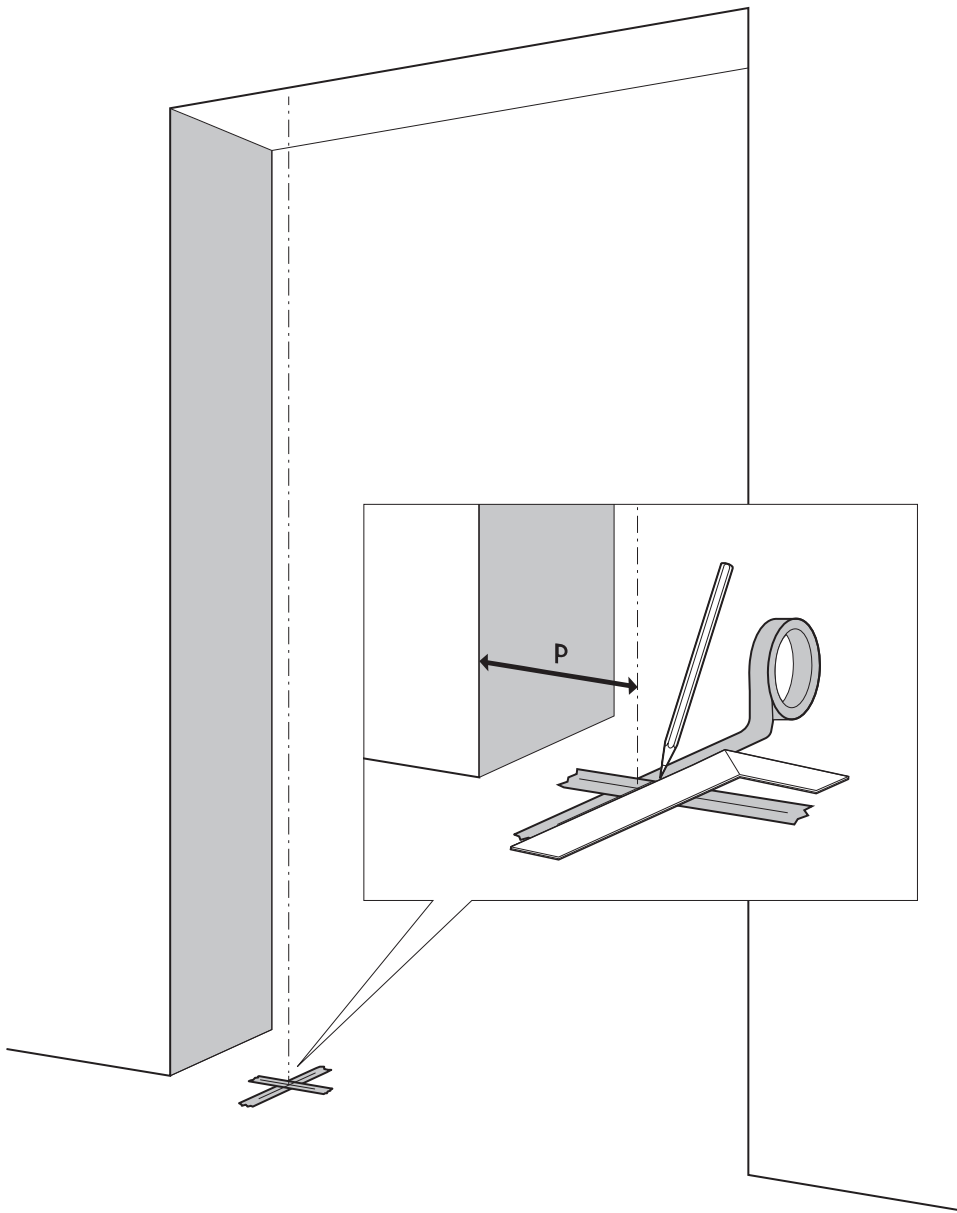

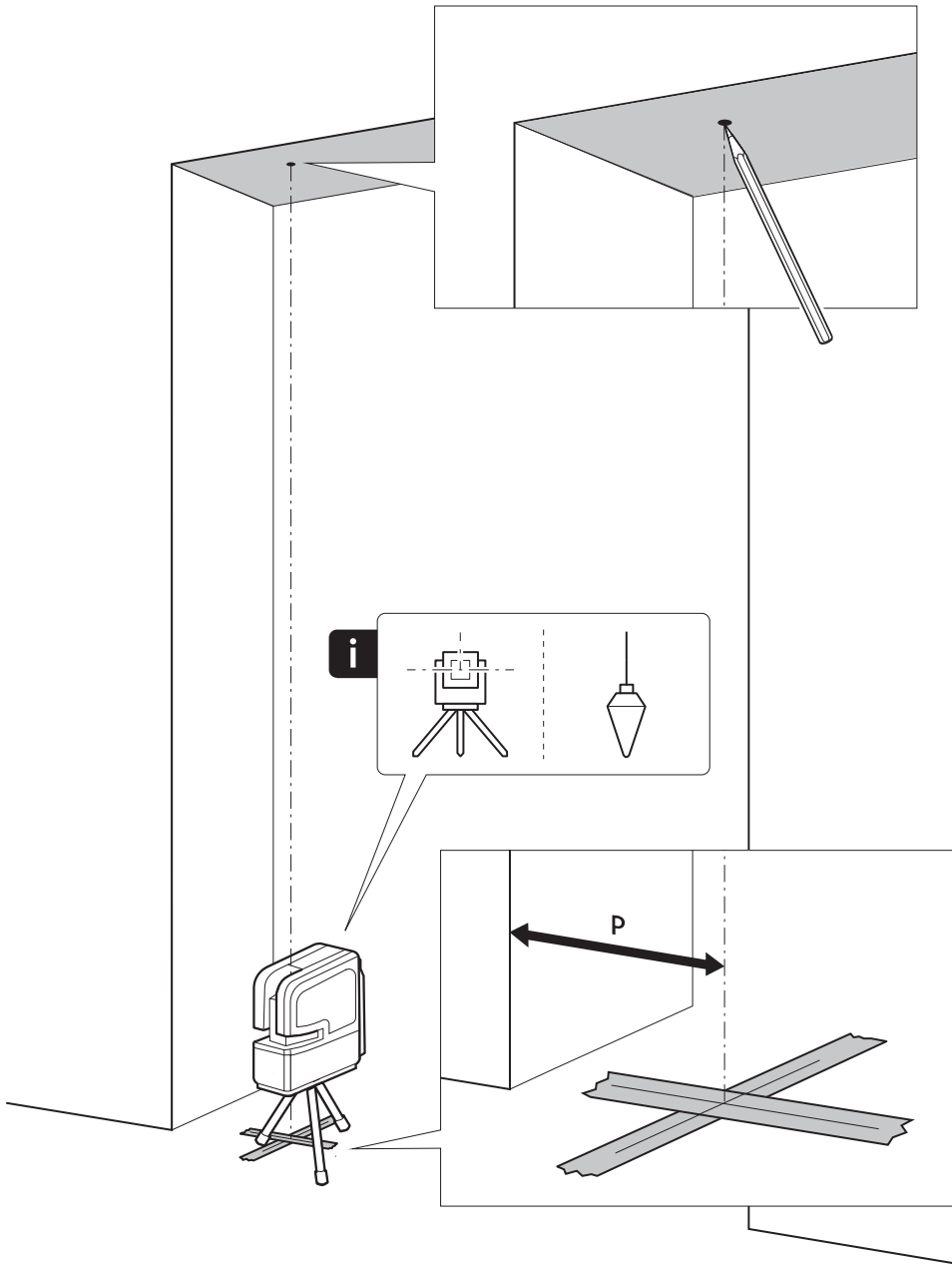
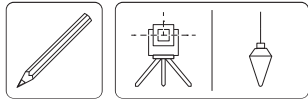

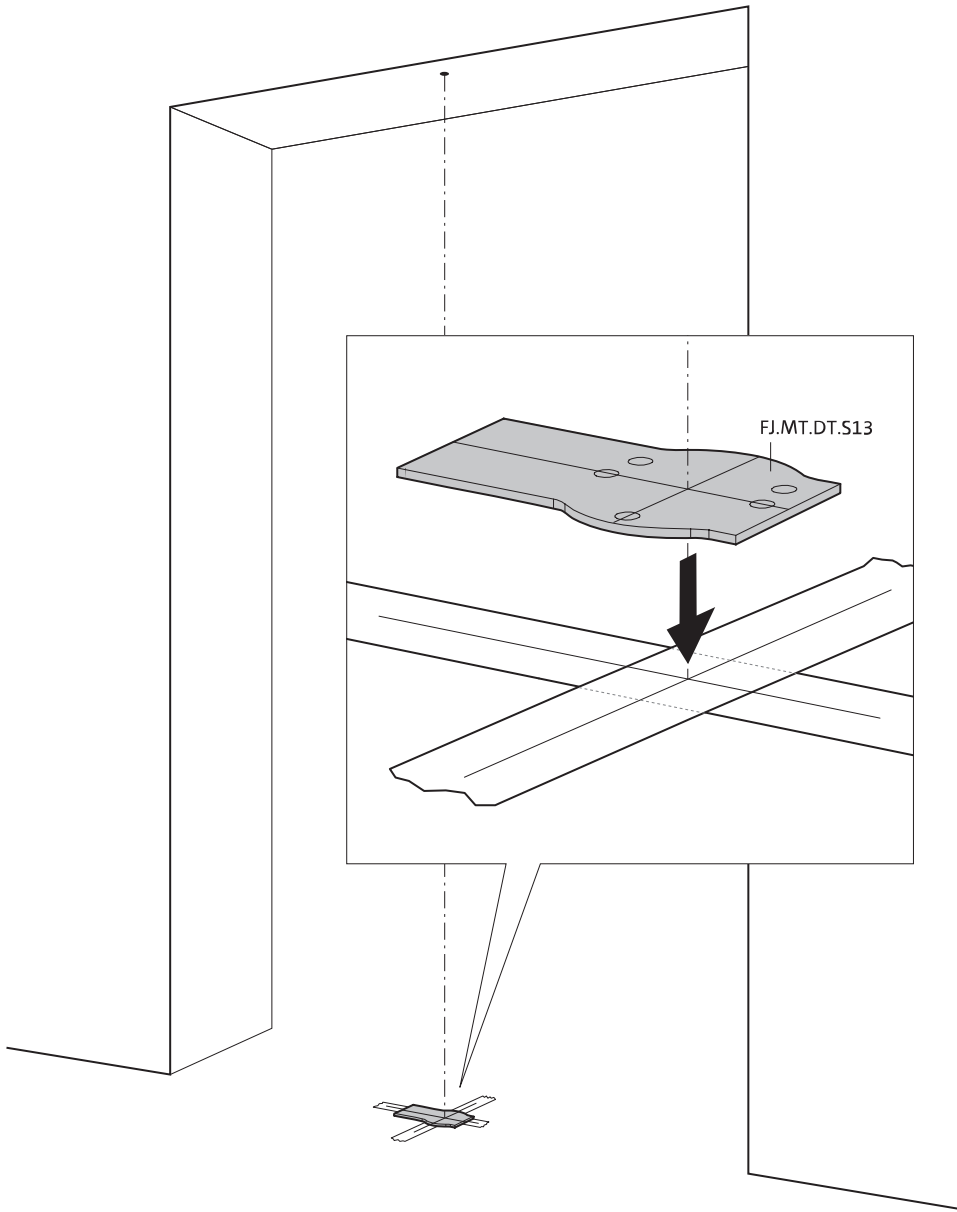



ø8 mm (5/16")

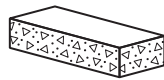

ø8 mm (5/16")

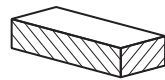

ø7.5 mm (19/64")

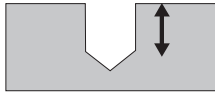

8 mm (5/16")

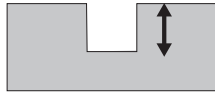

8 mm (5/16")

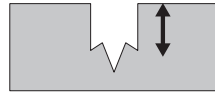

8 mm (5/16")

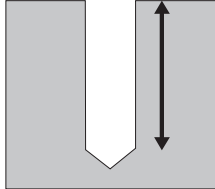

30 mm (13/16")

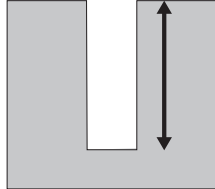

30 mm (13/16")

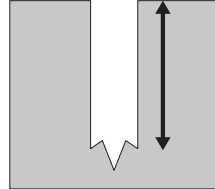

30 mm (13/16")

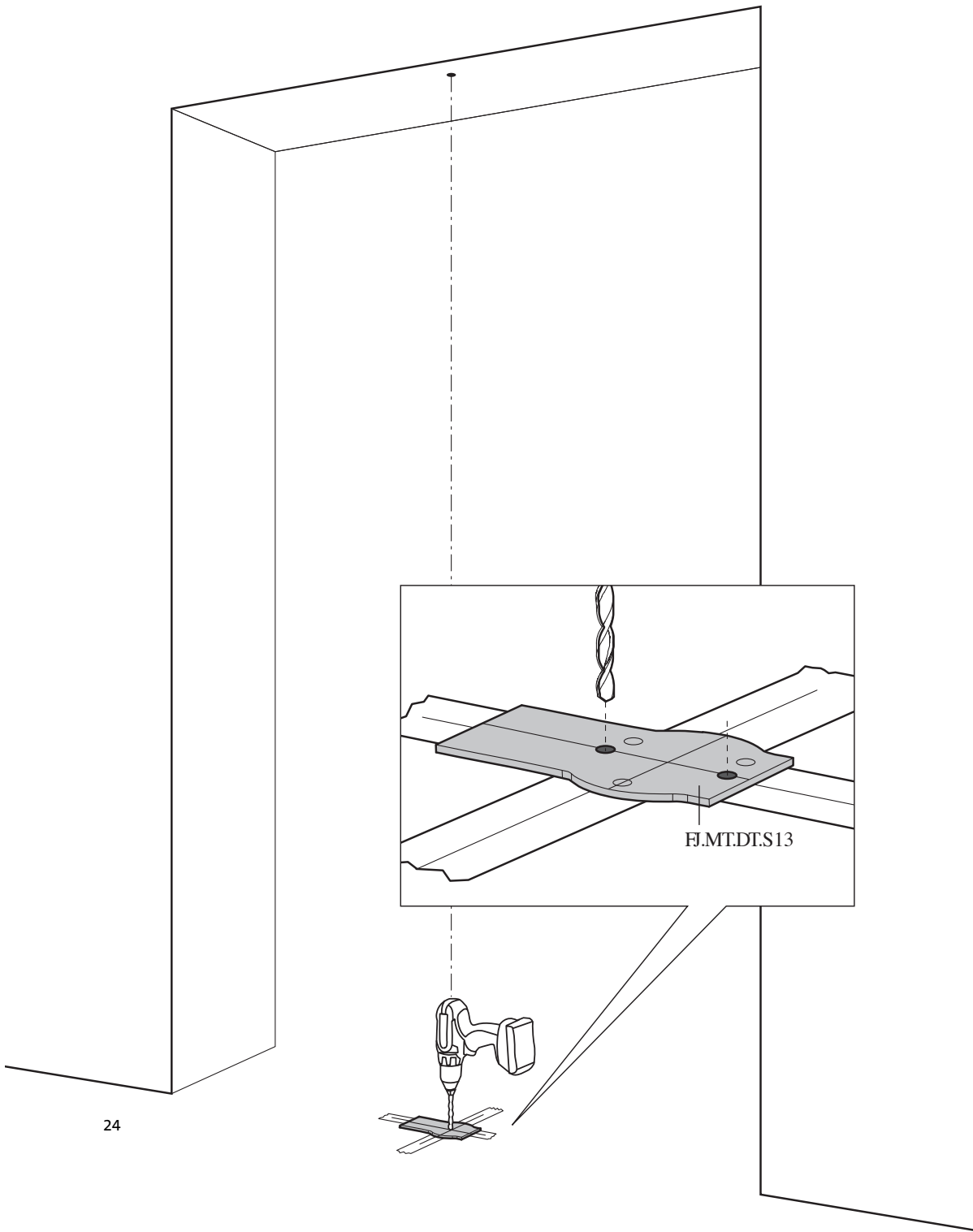
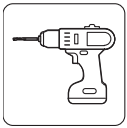

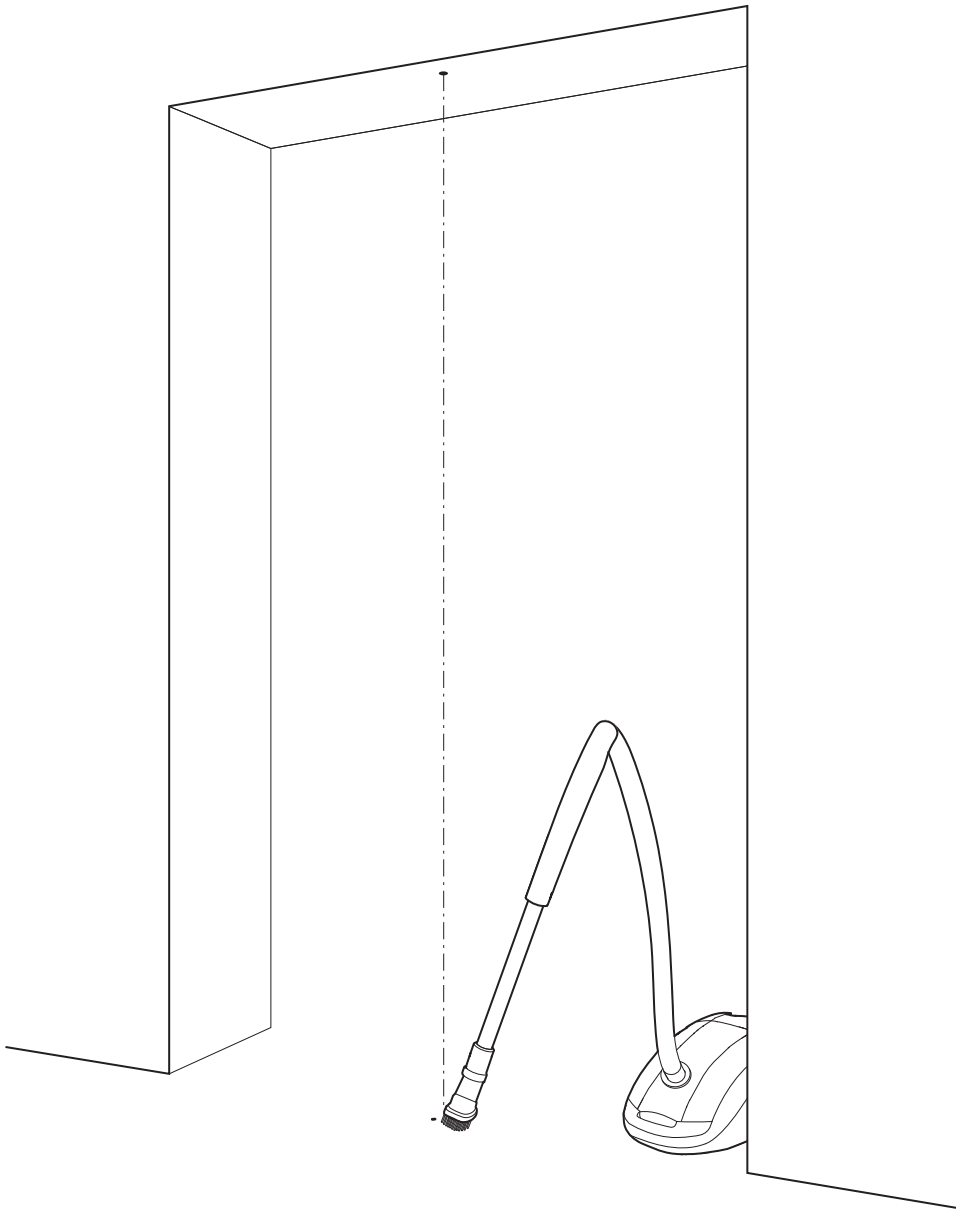



1

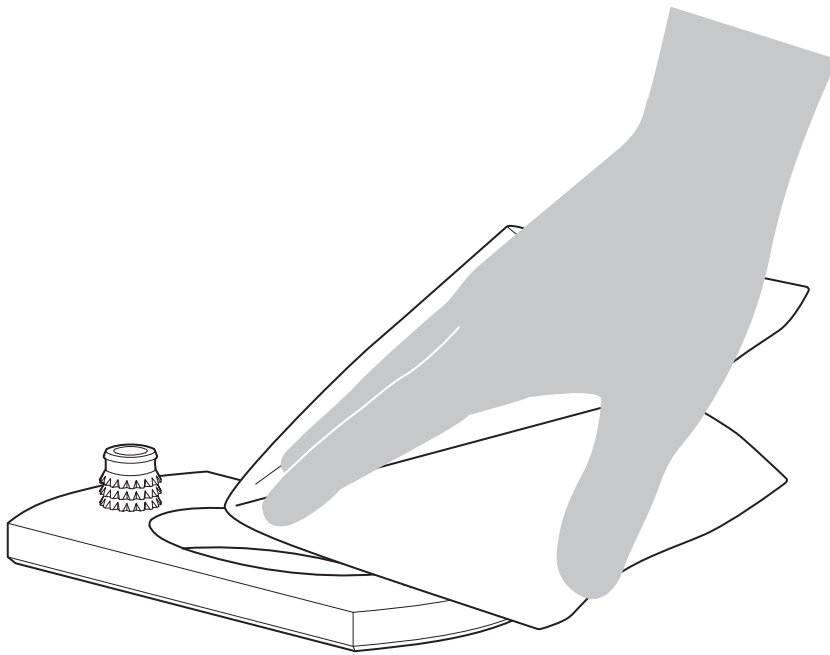

2

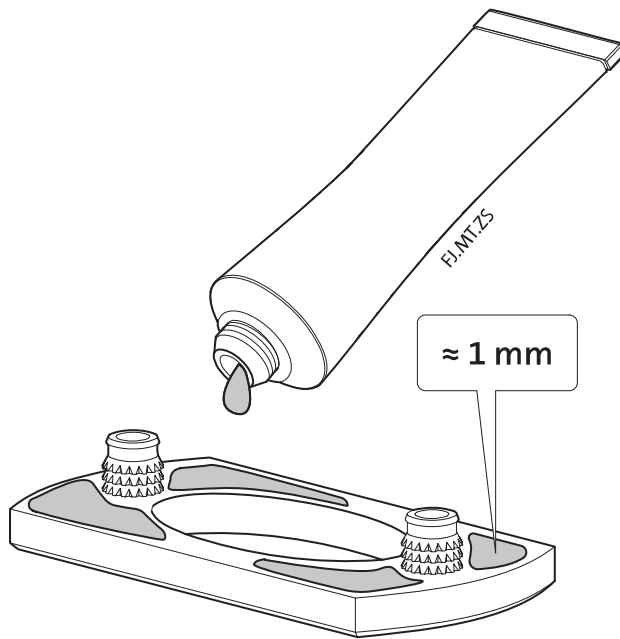

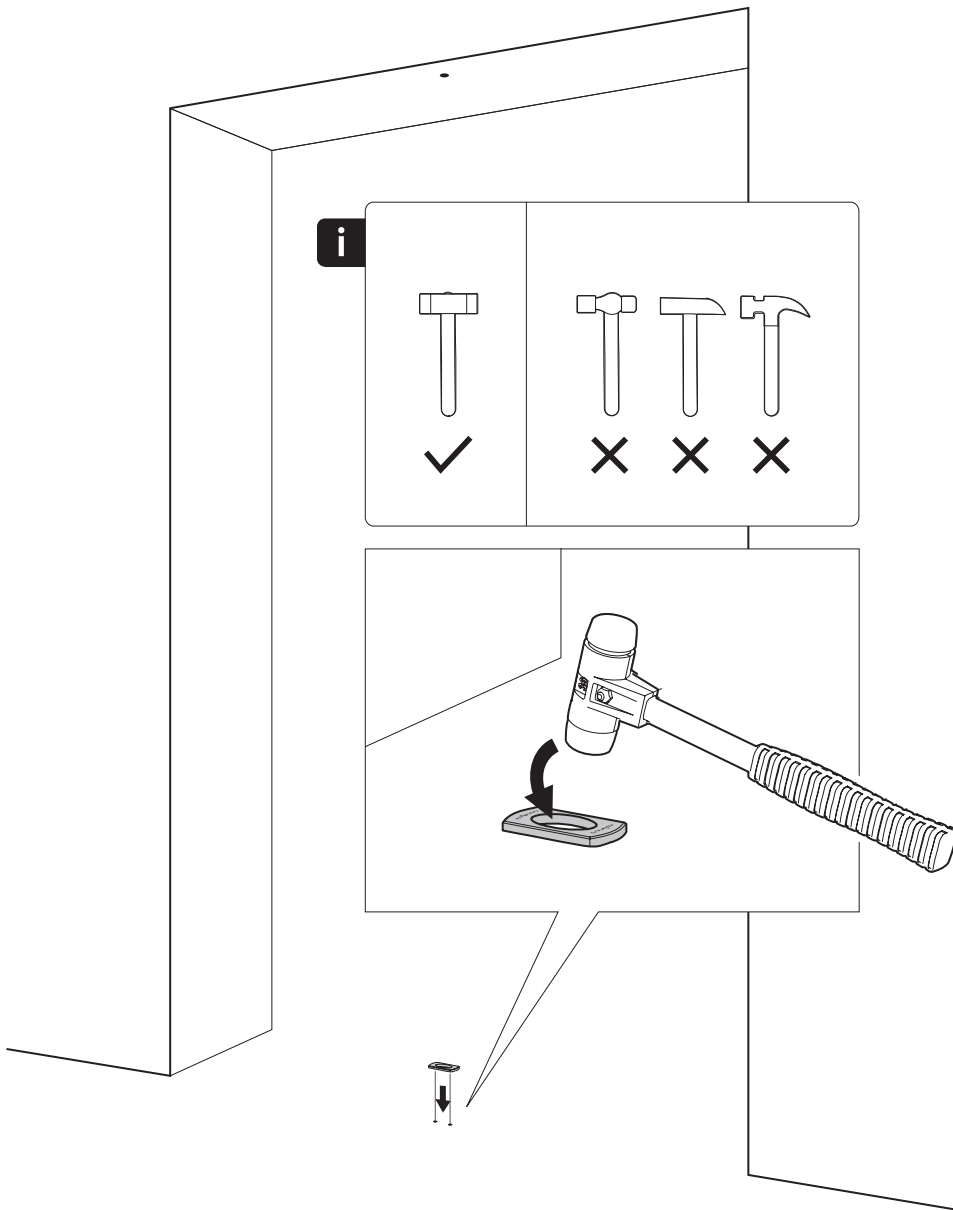
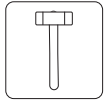

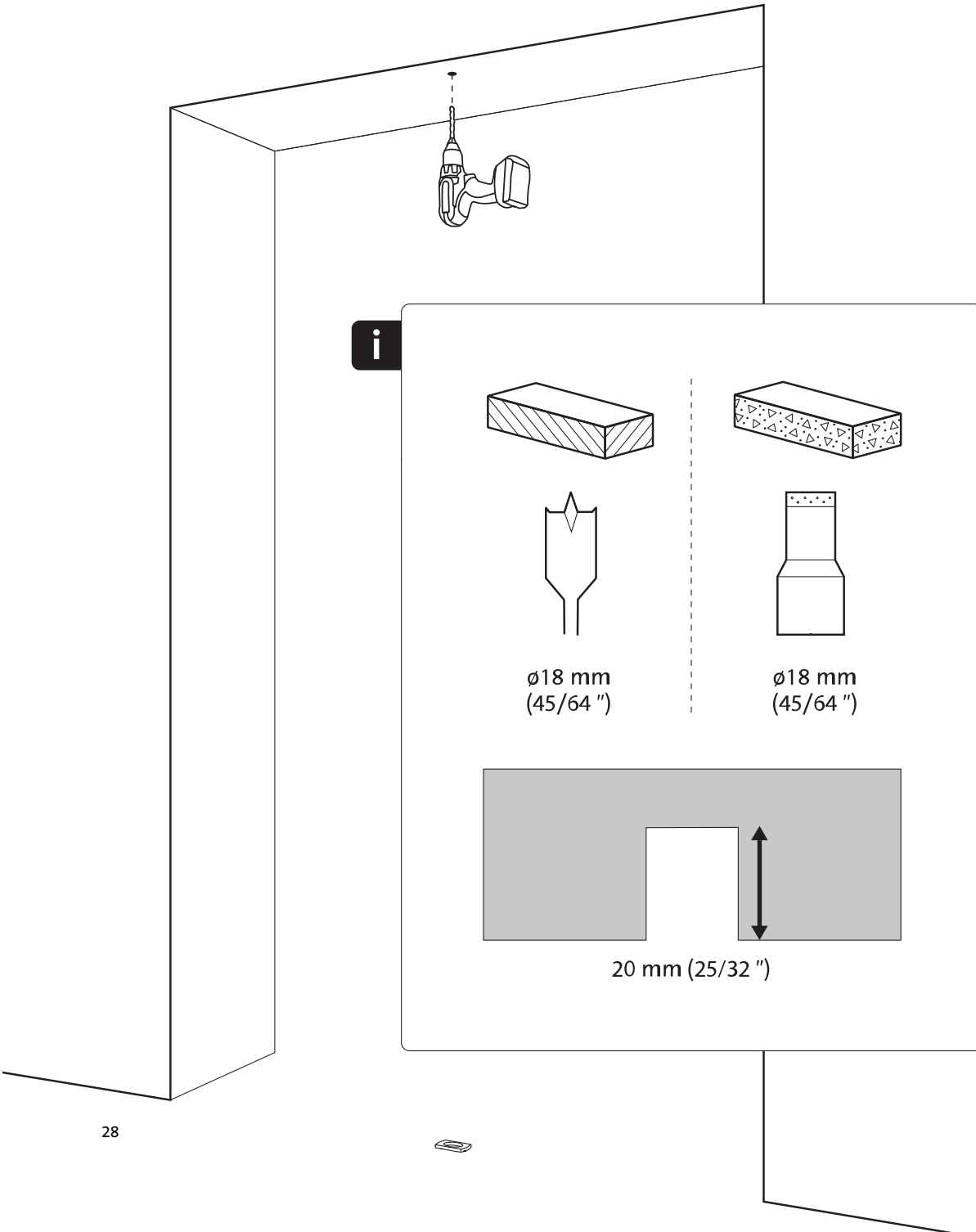
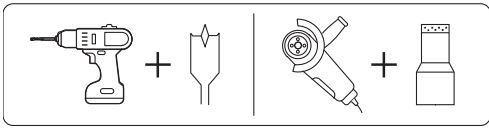



1

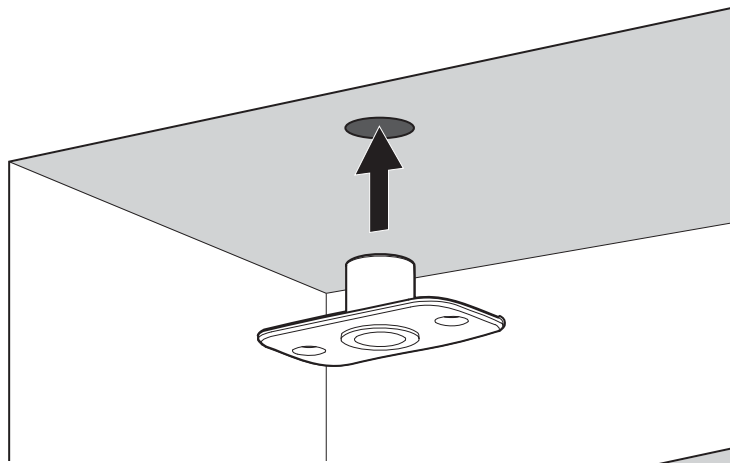

2

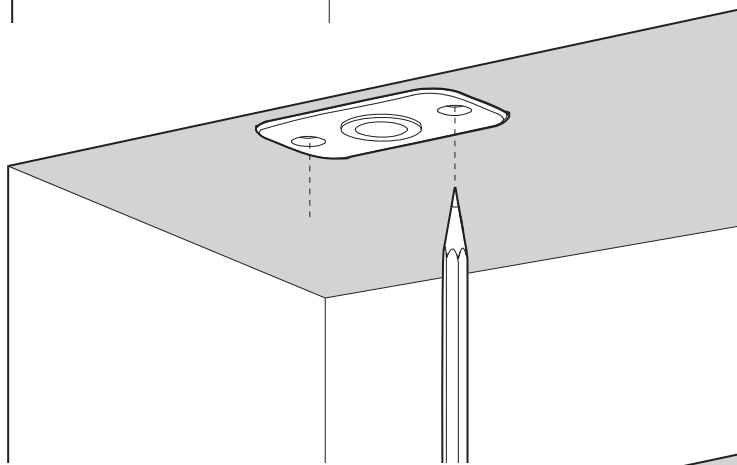

3

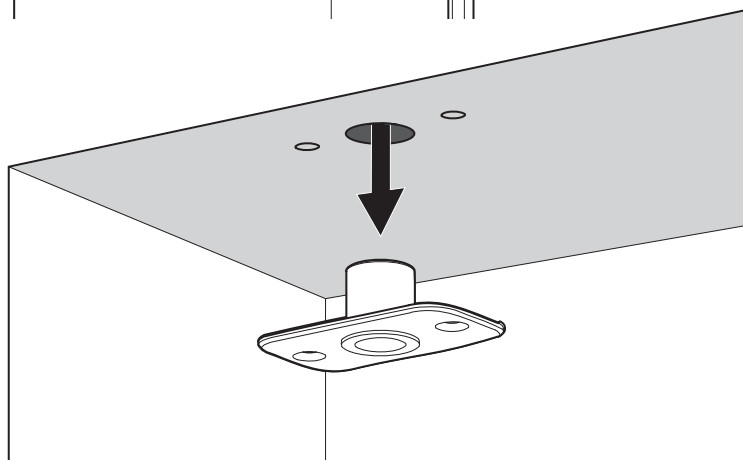



1

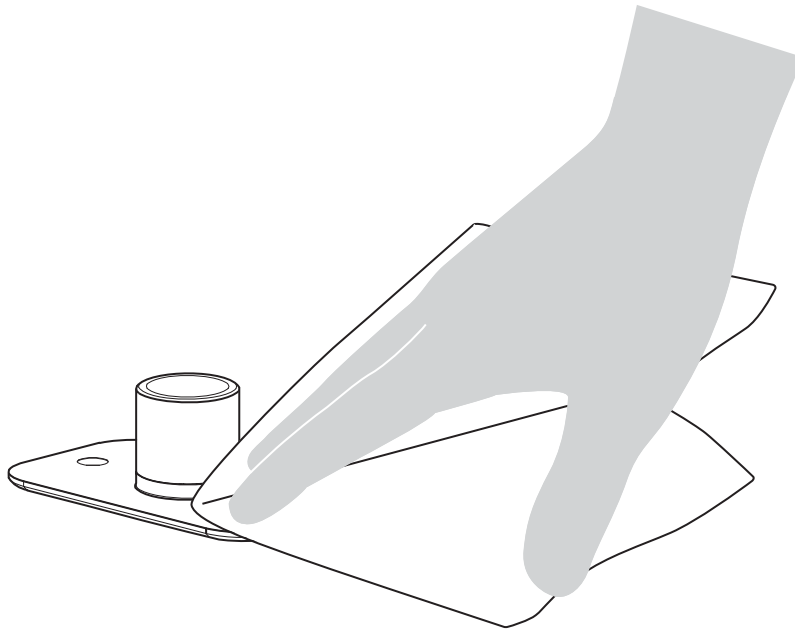

2

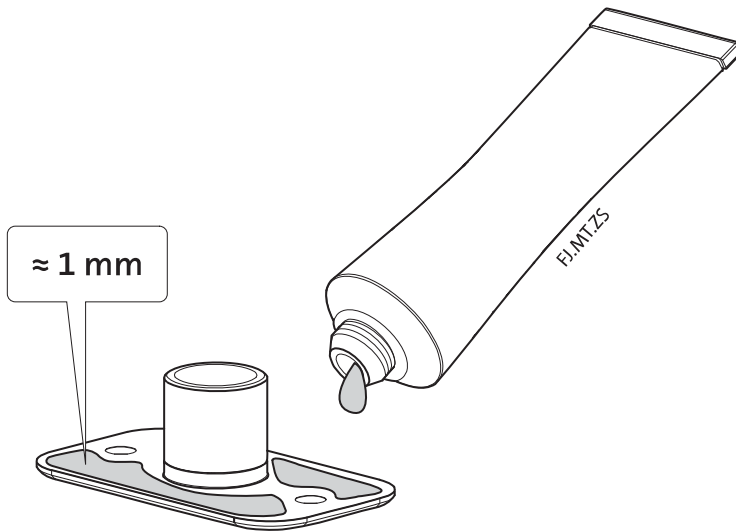

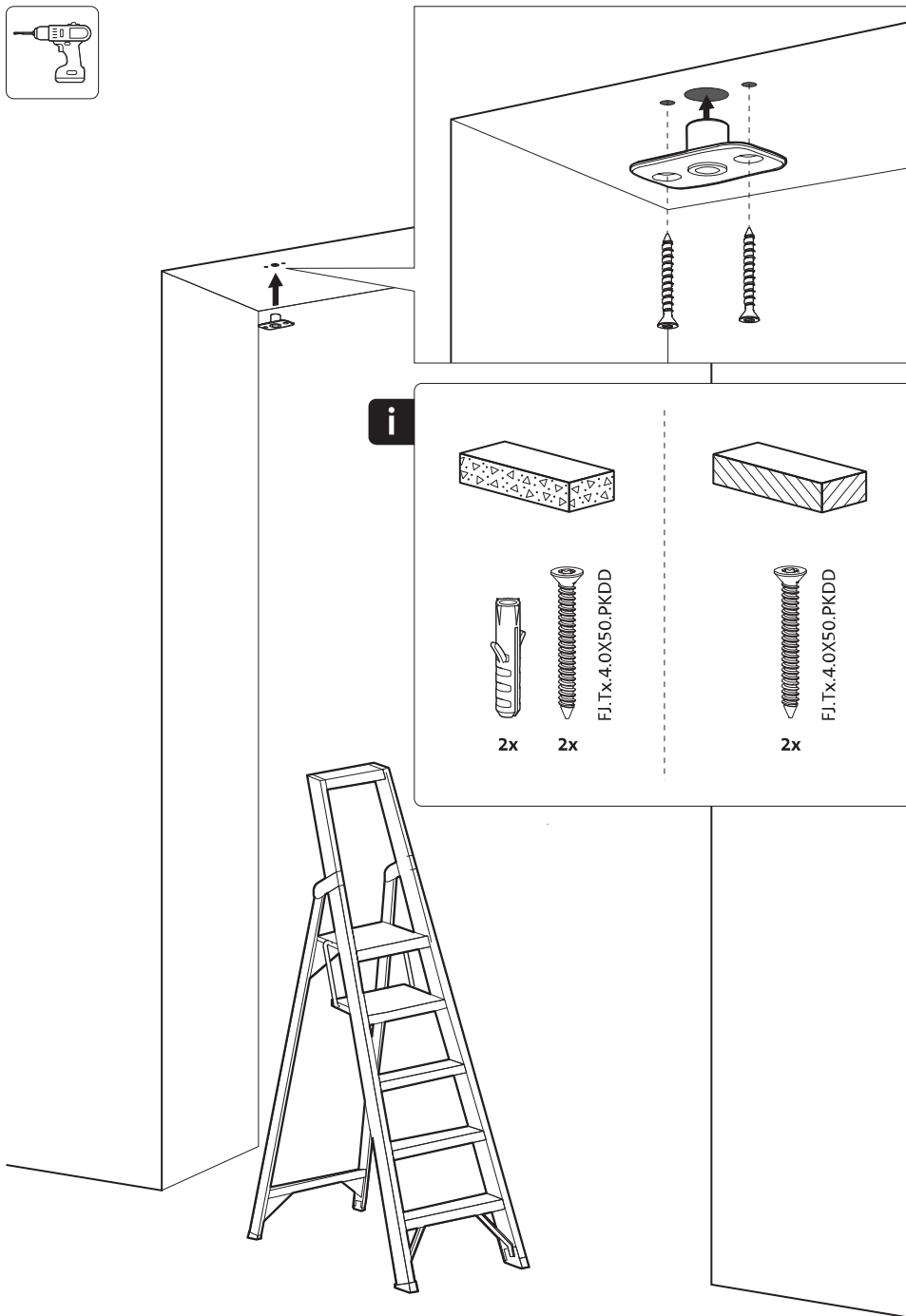

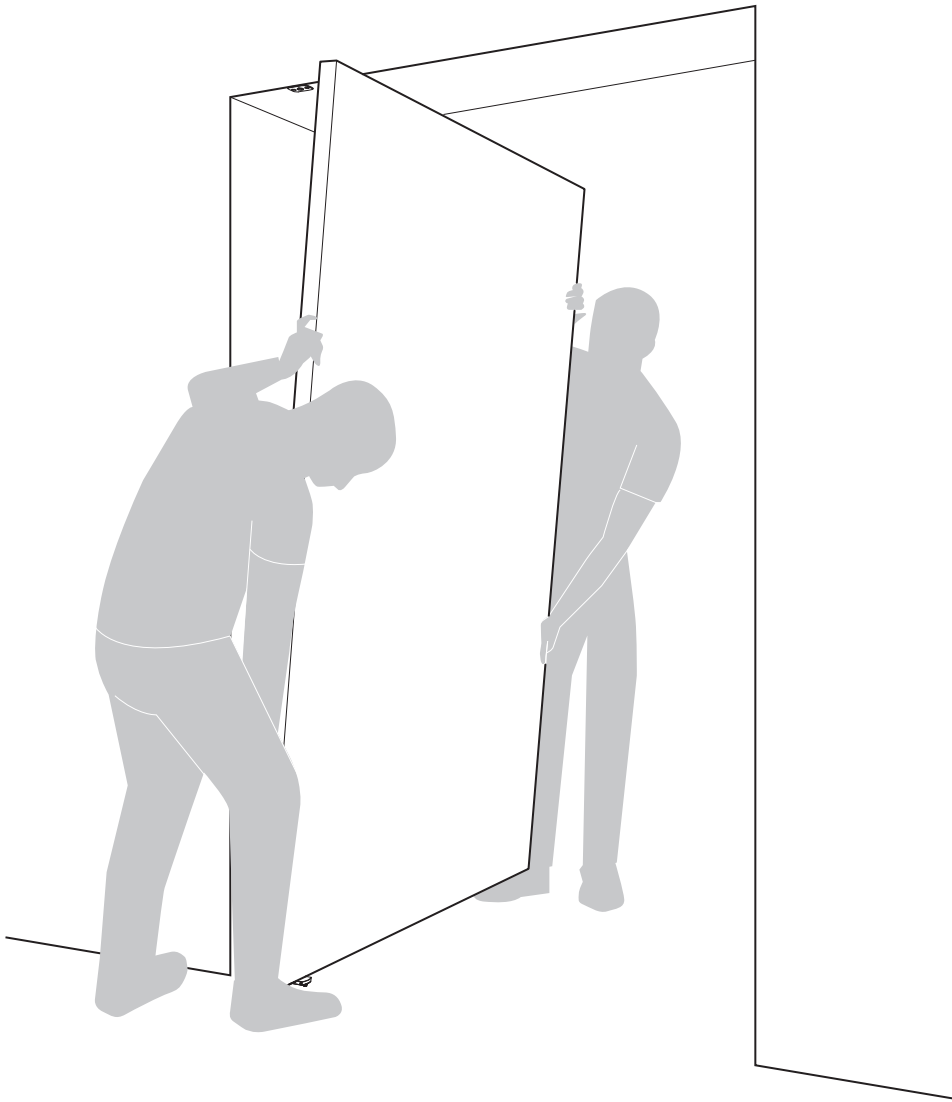

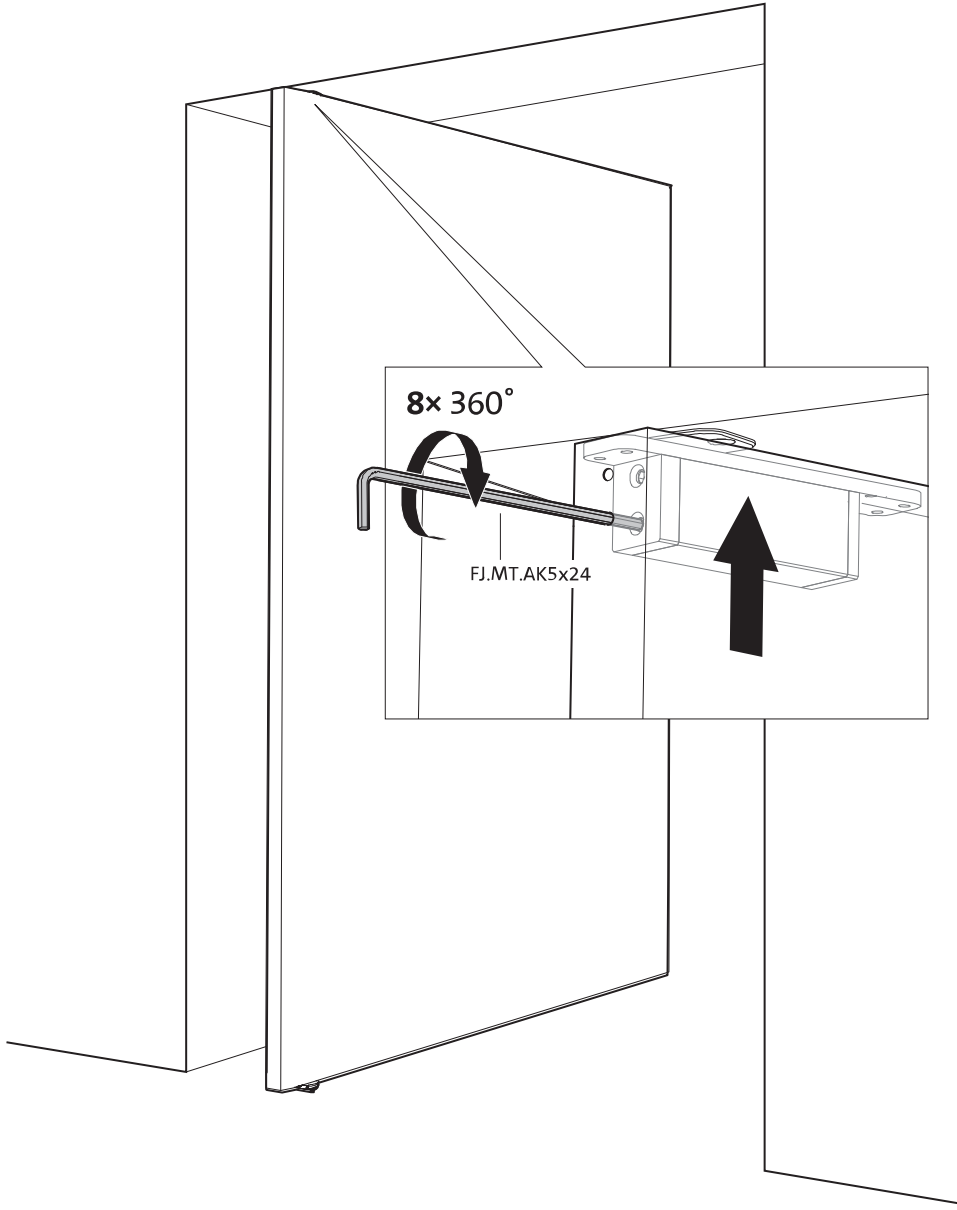
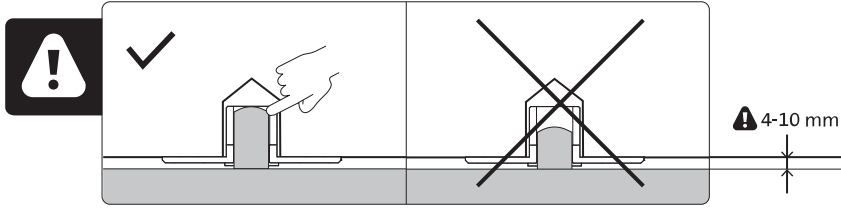

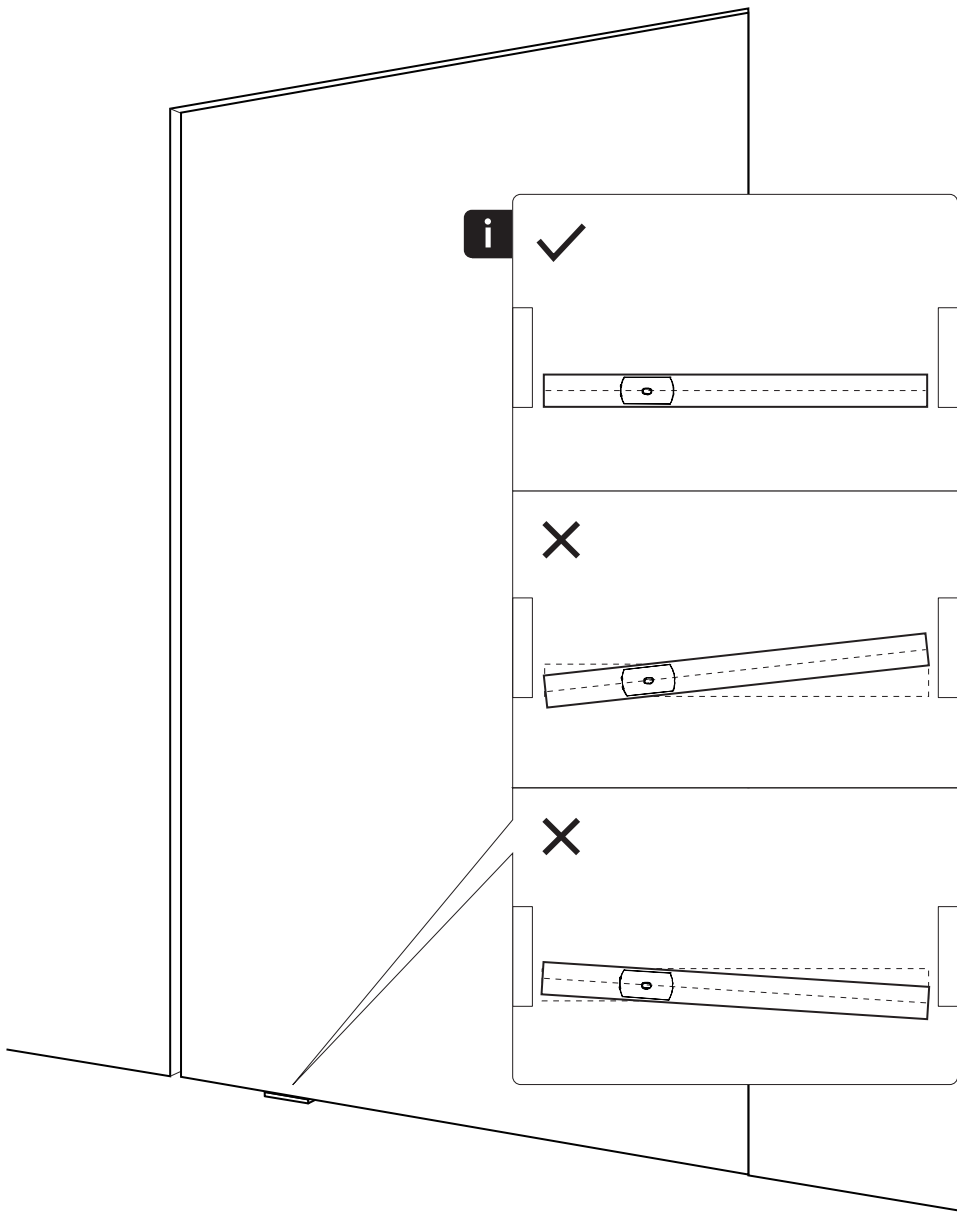

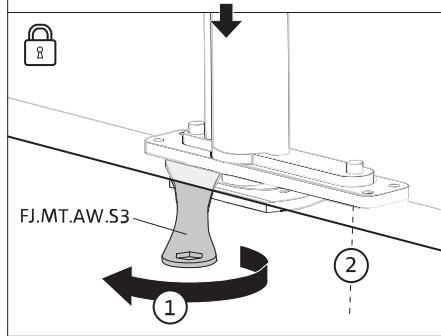
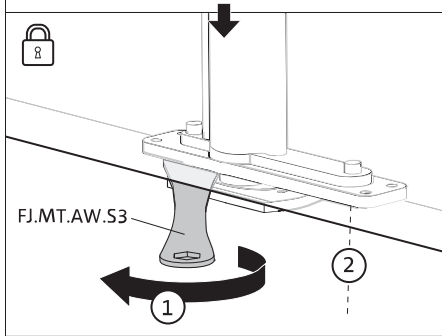
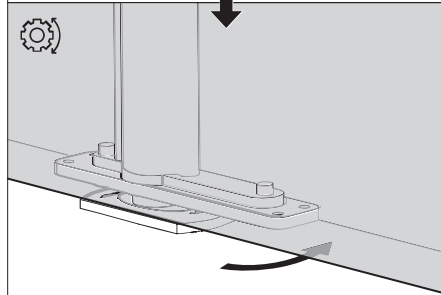
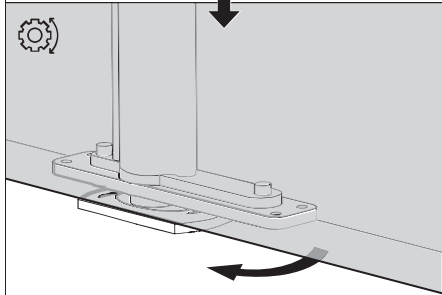
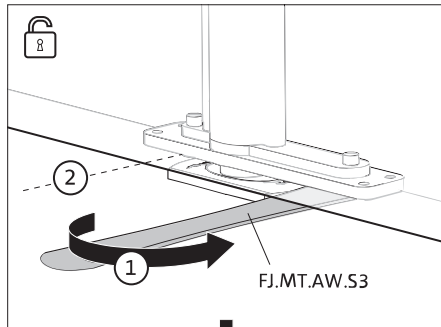
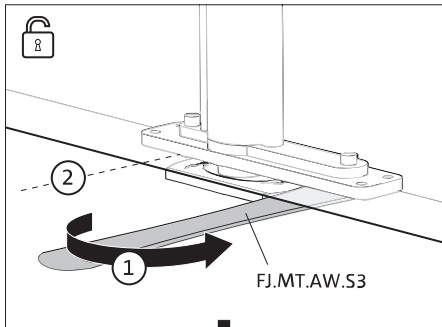
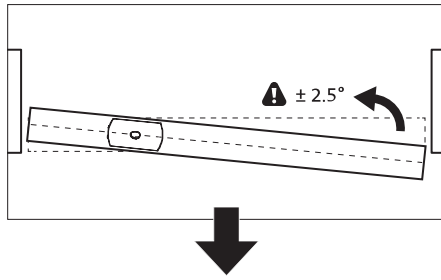
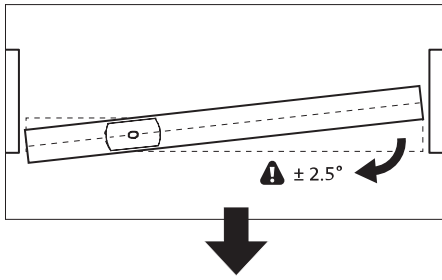

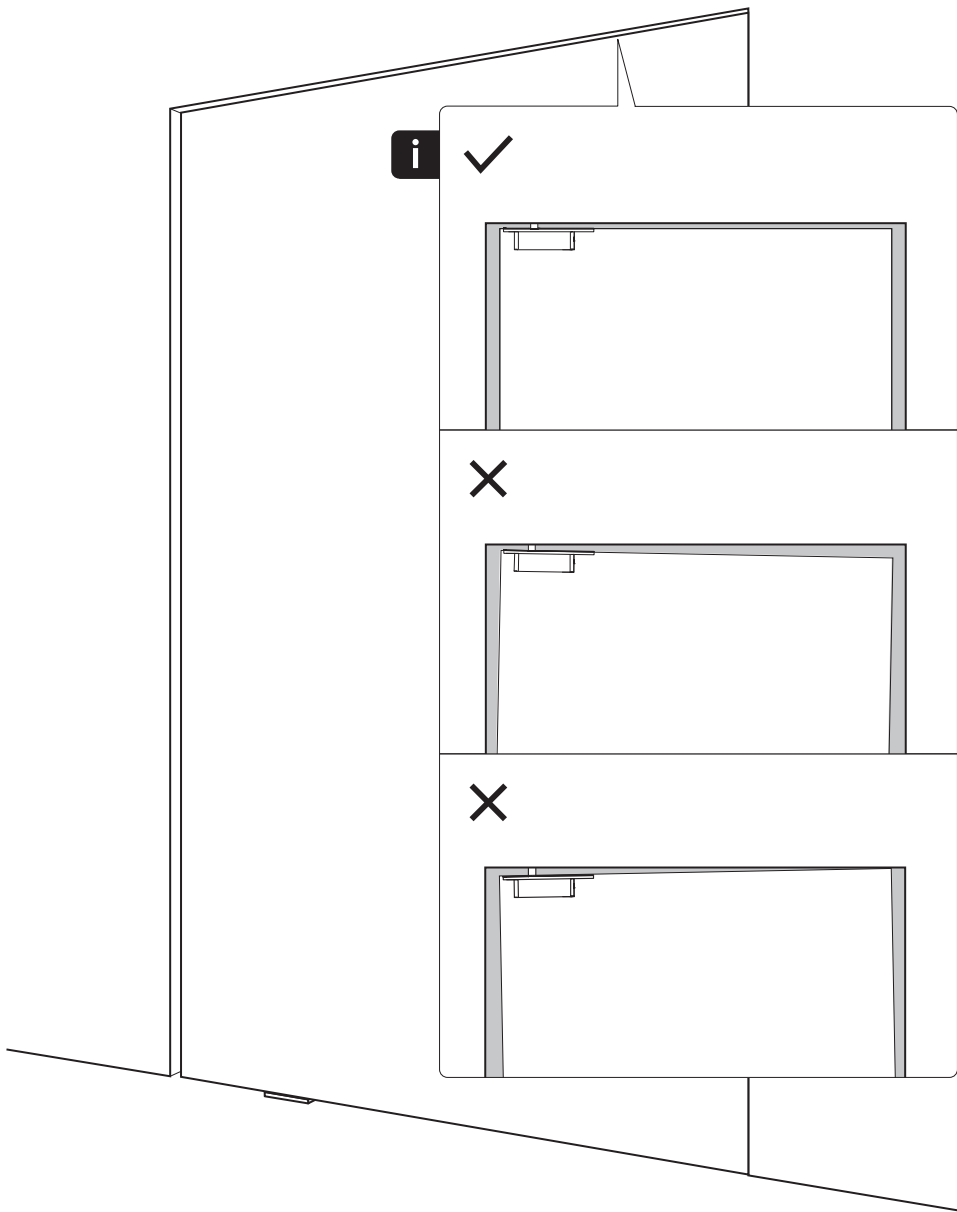

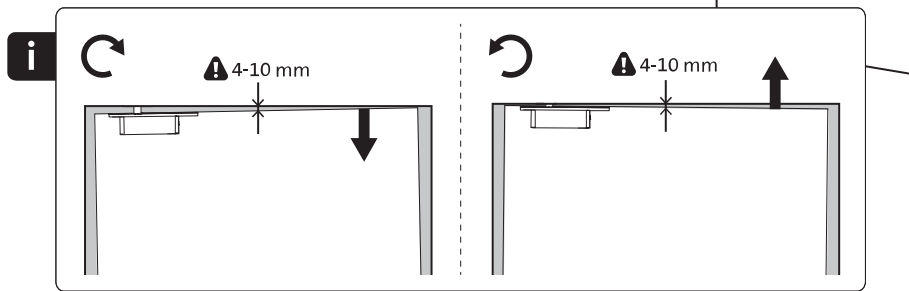
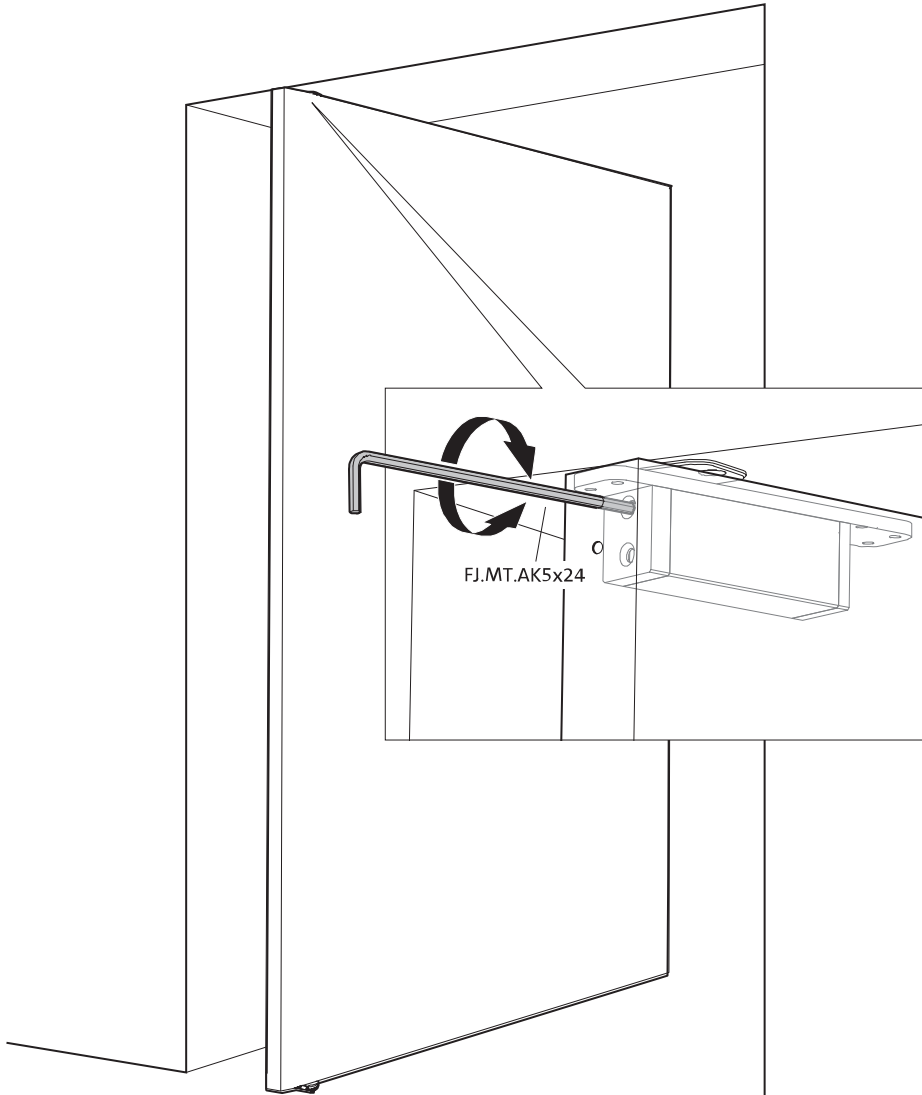

Disassembly instructions

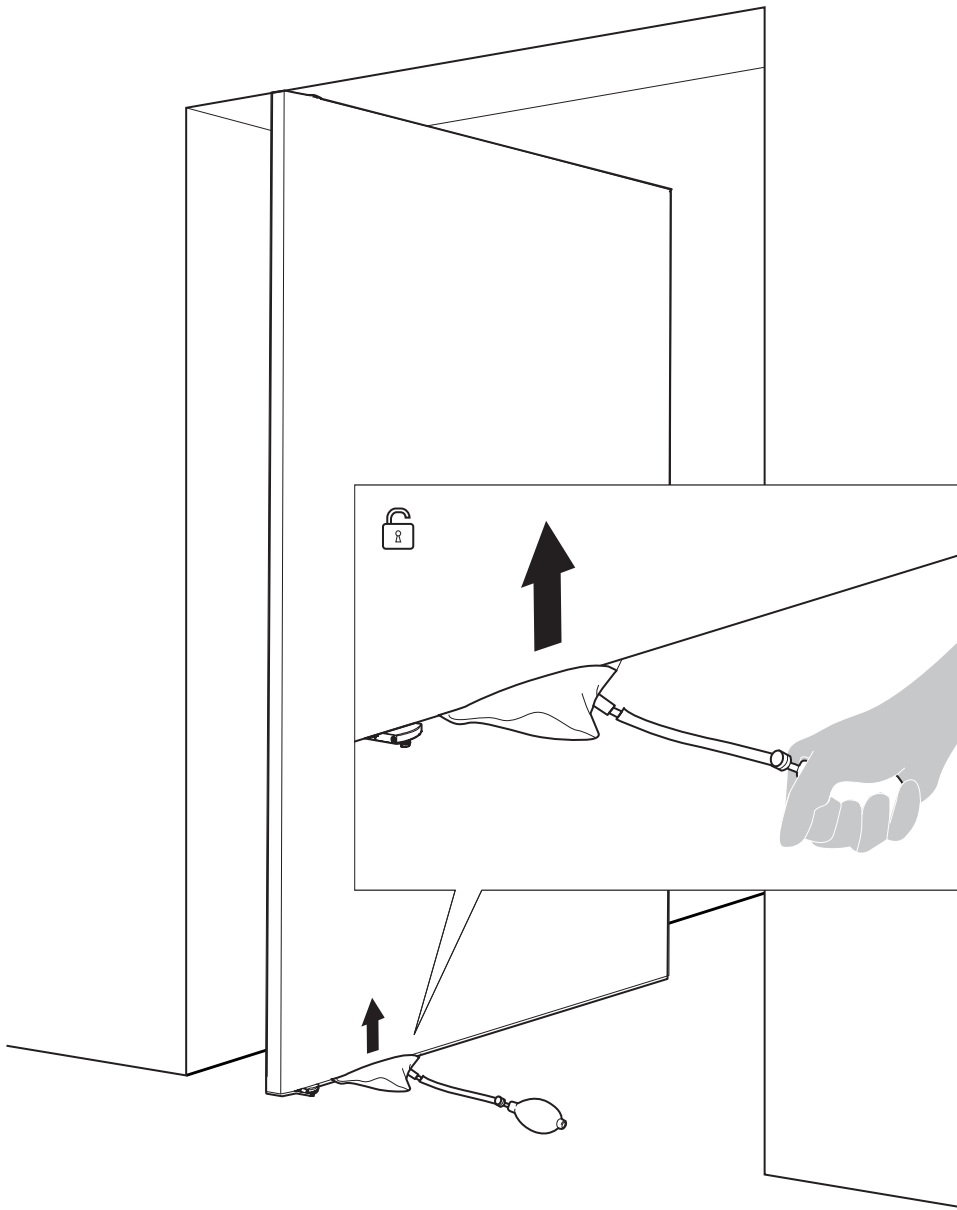

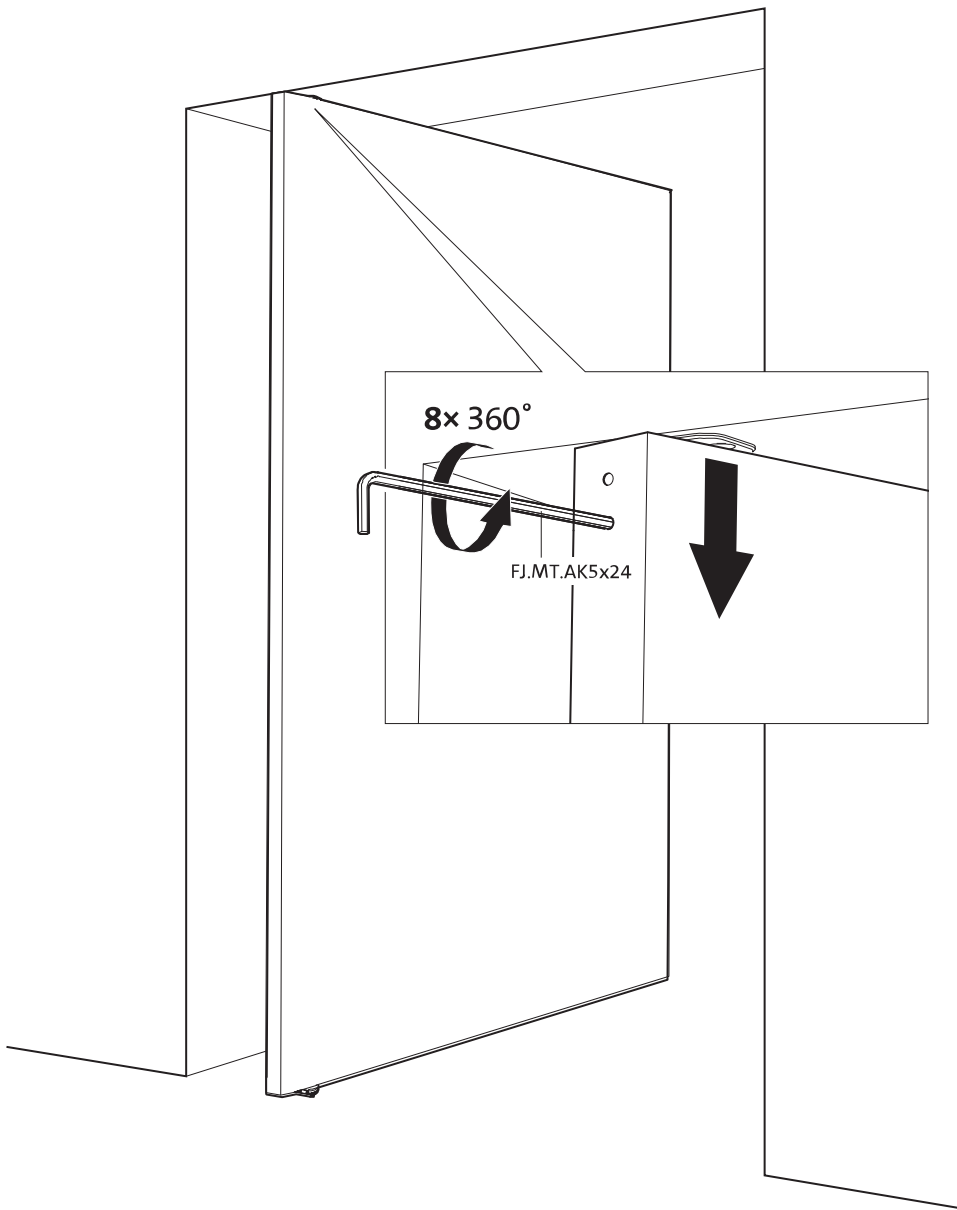

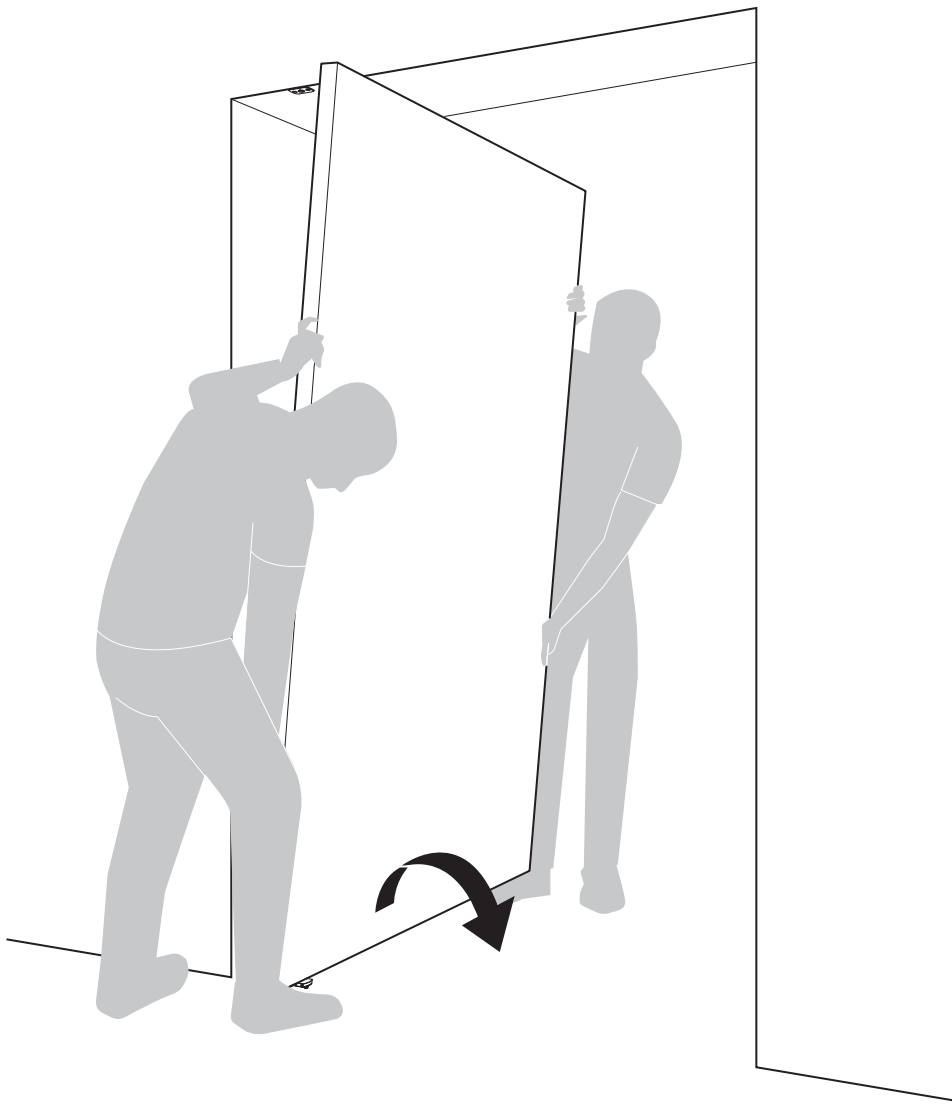

FritsJurgens International

A. Einsteinlaan 1
The Netherlands
9615 TE Kolham
+31 598 343 410
info@fritsjurgens.com

FritsJurgens Dubai Branch

DLC-OP-A2-4-0029
Dubai South
Dubai
United Arab Emirates
+971 4 820 8106
+971 58 137 2611
dubai@fritsjurgens.com
fritsjurgens.com

Copyright © FritsJurgens®
BPS3.70.G.X.XX

