

# System M

## Milling and mounting manual

FritsJurgens Set - 70 mm Class C - invisible

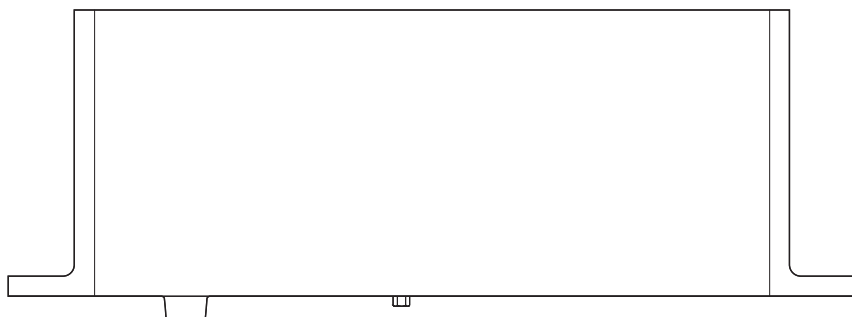

FritsJurgens®



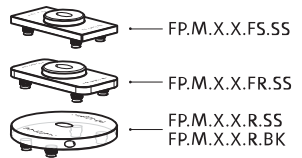
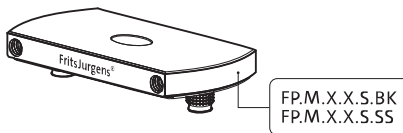
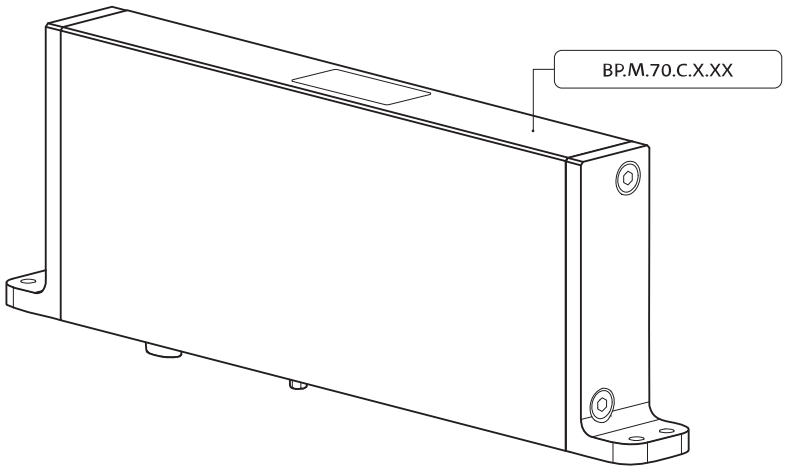
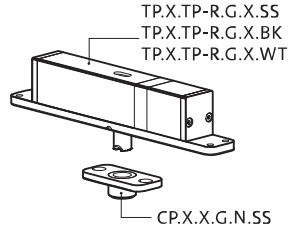
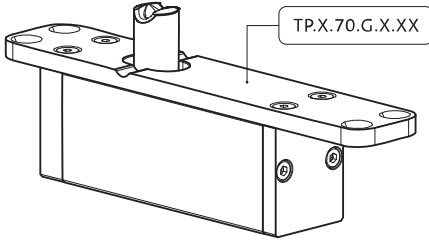
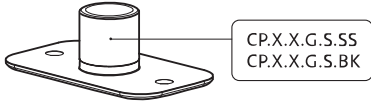



# Milling instructions

# BP.M.70.C.X.XX

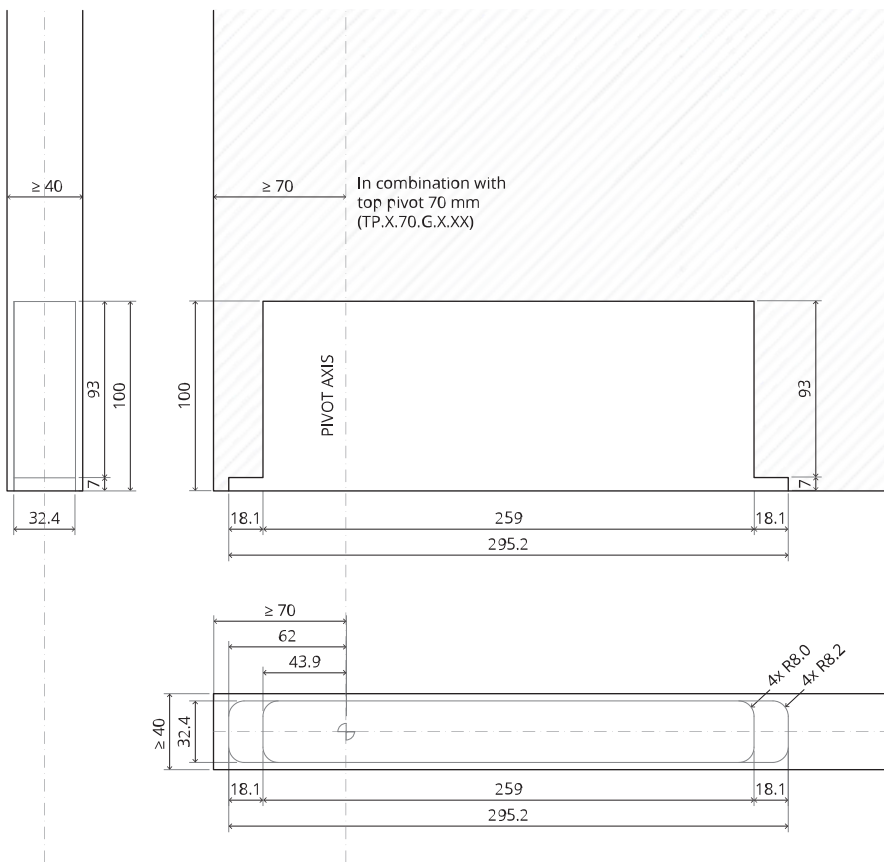

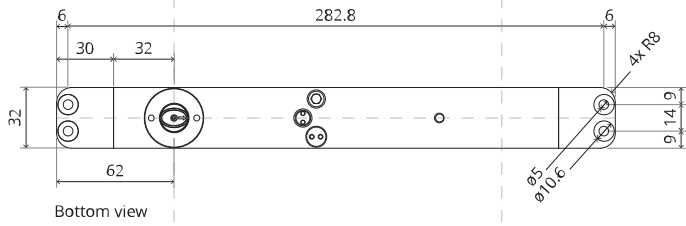
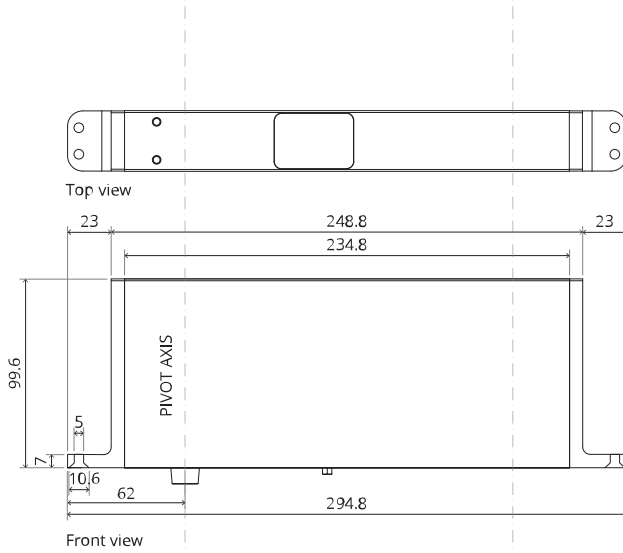
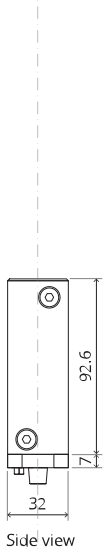

# TP.X.70.G.X.XX

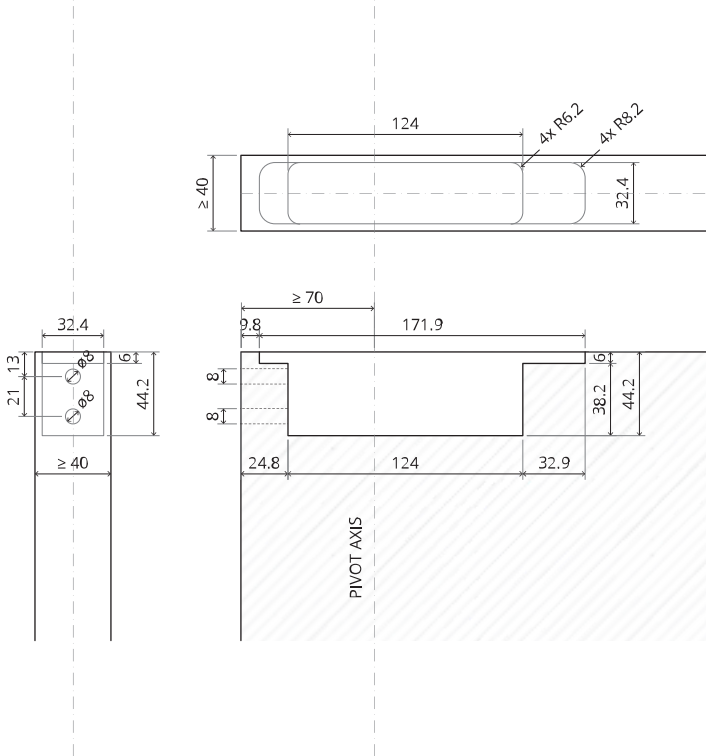



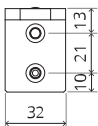

Side view A with pin turned in

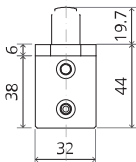

Side view A with pin turned out

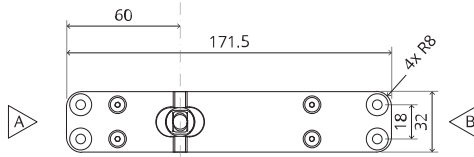

Top view

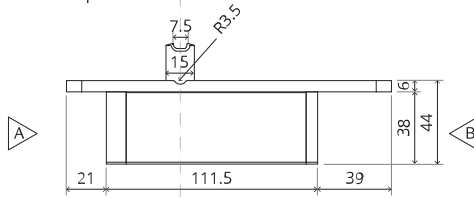

Front view

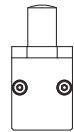

Side view B

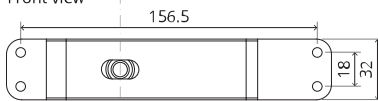

Bottom view

# TP.X.TP-R.G.X.

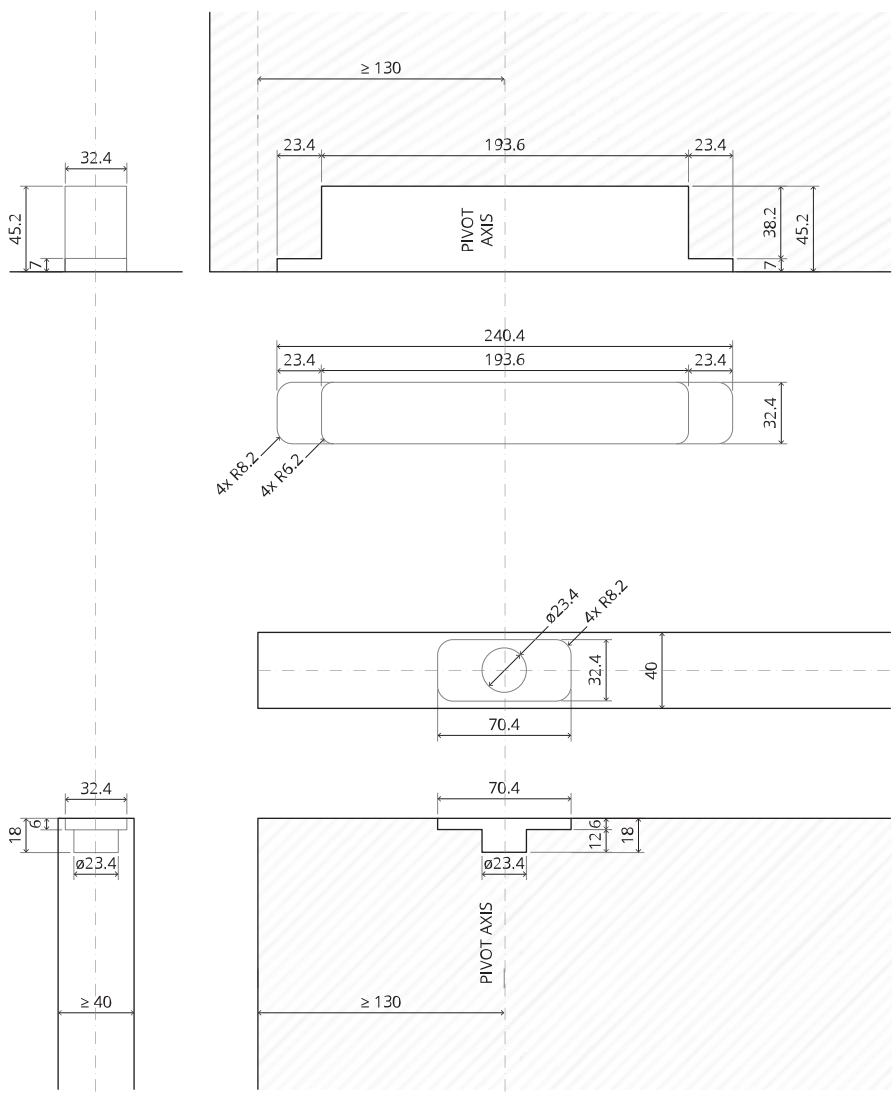

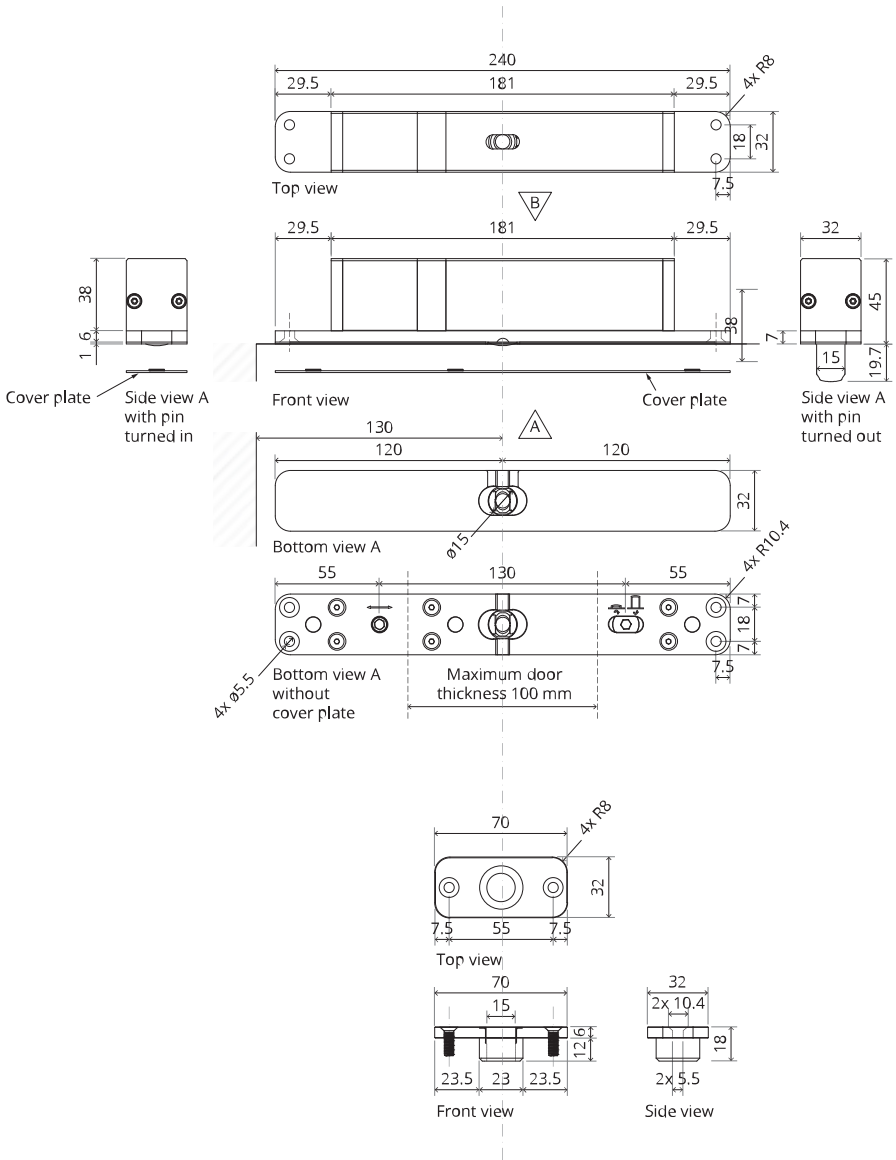

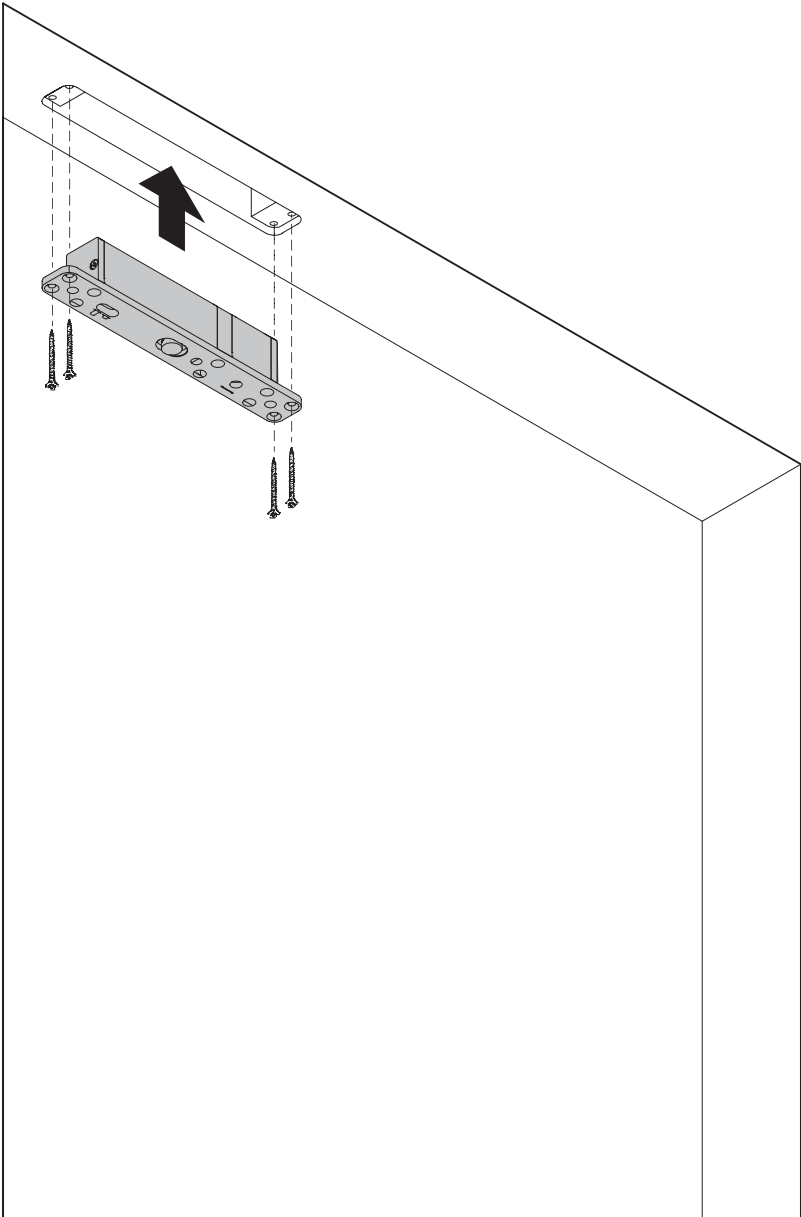

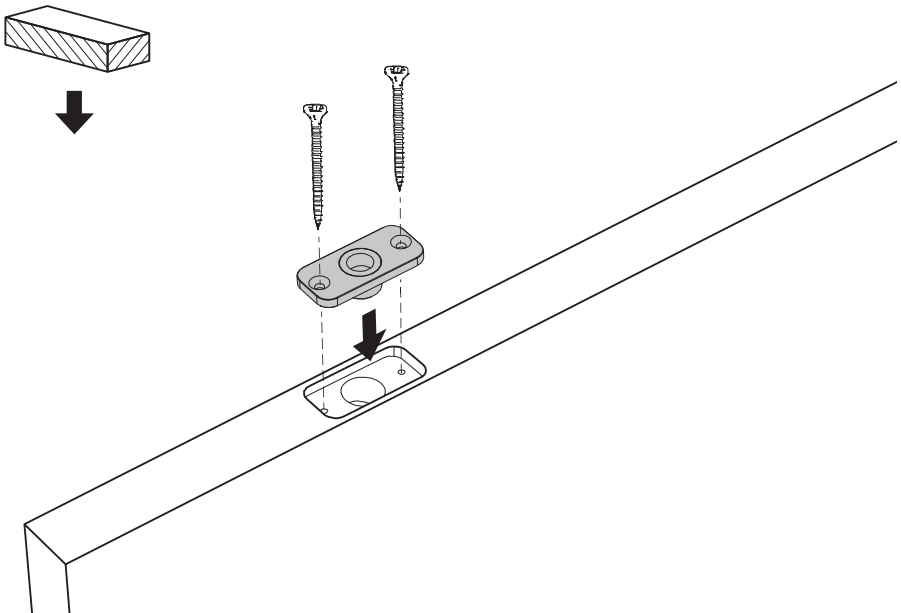
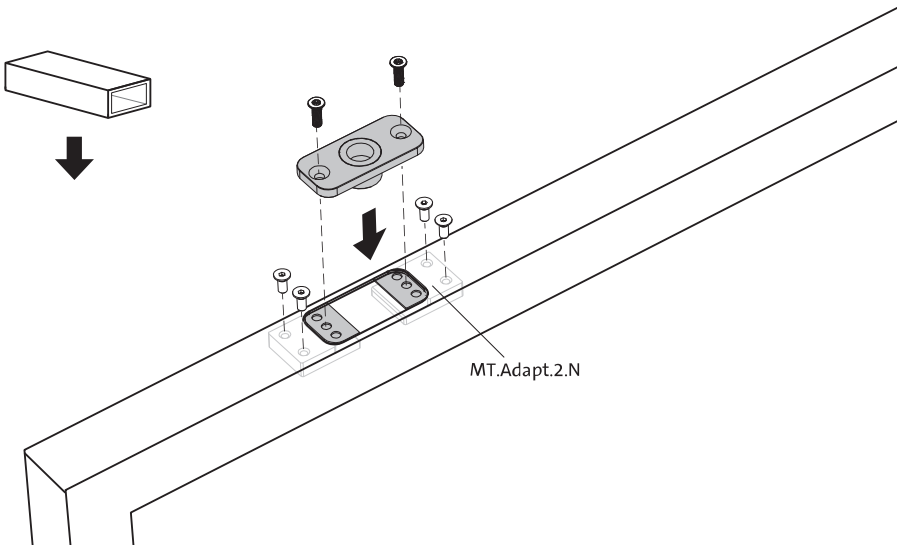

# FP.M.X.X.FS.SS

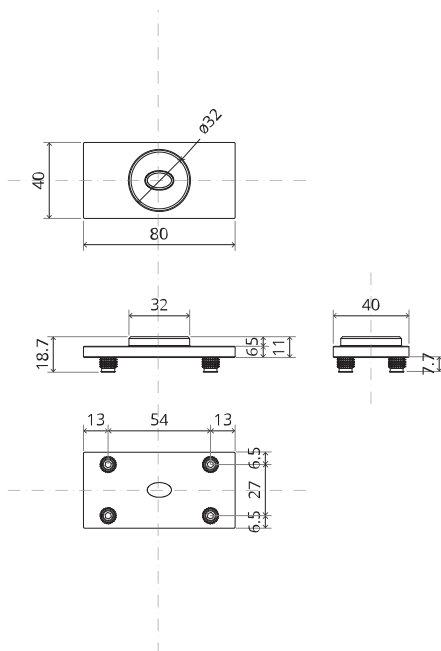
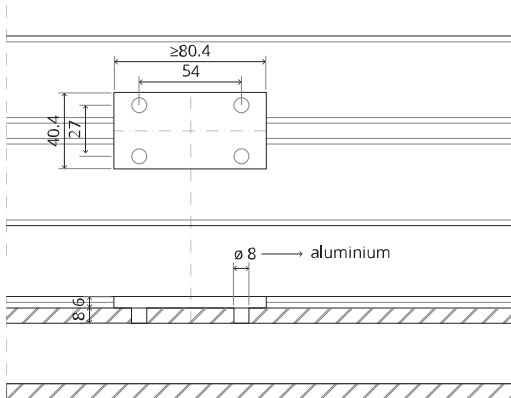

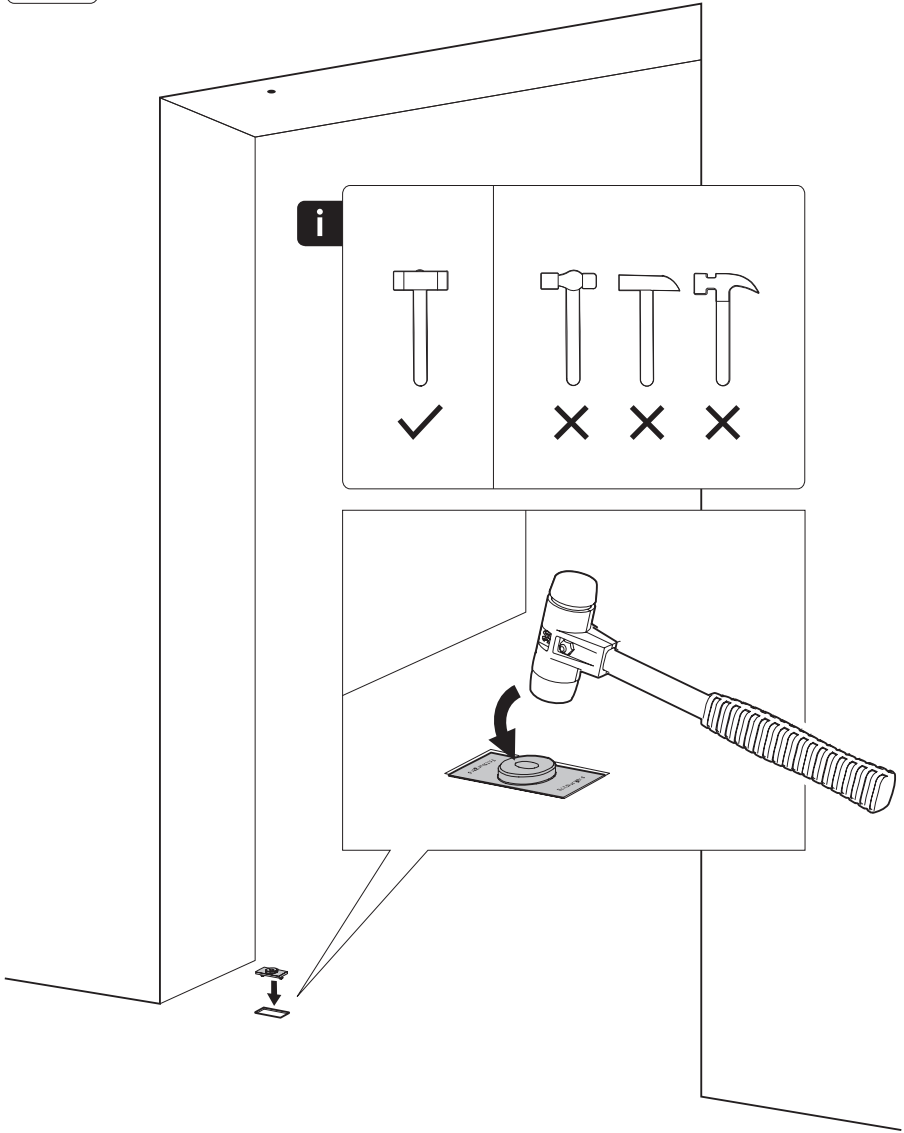

# FP.M.X.X.FR.SS

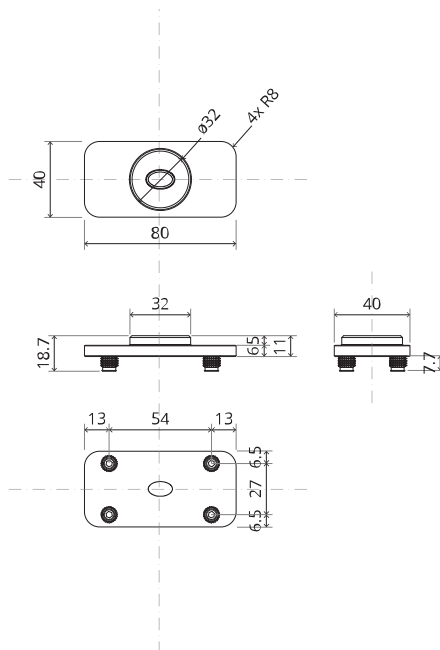
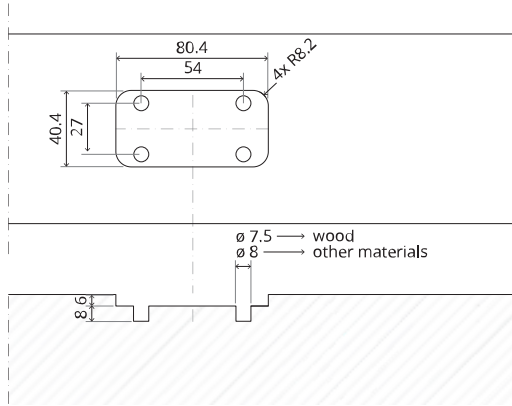



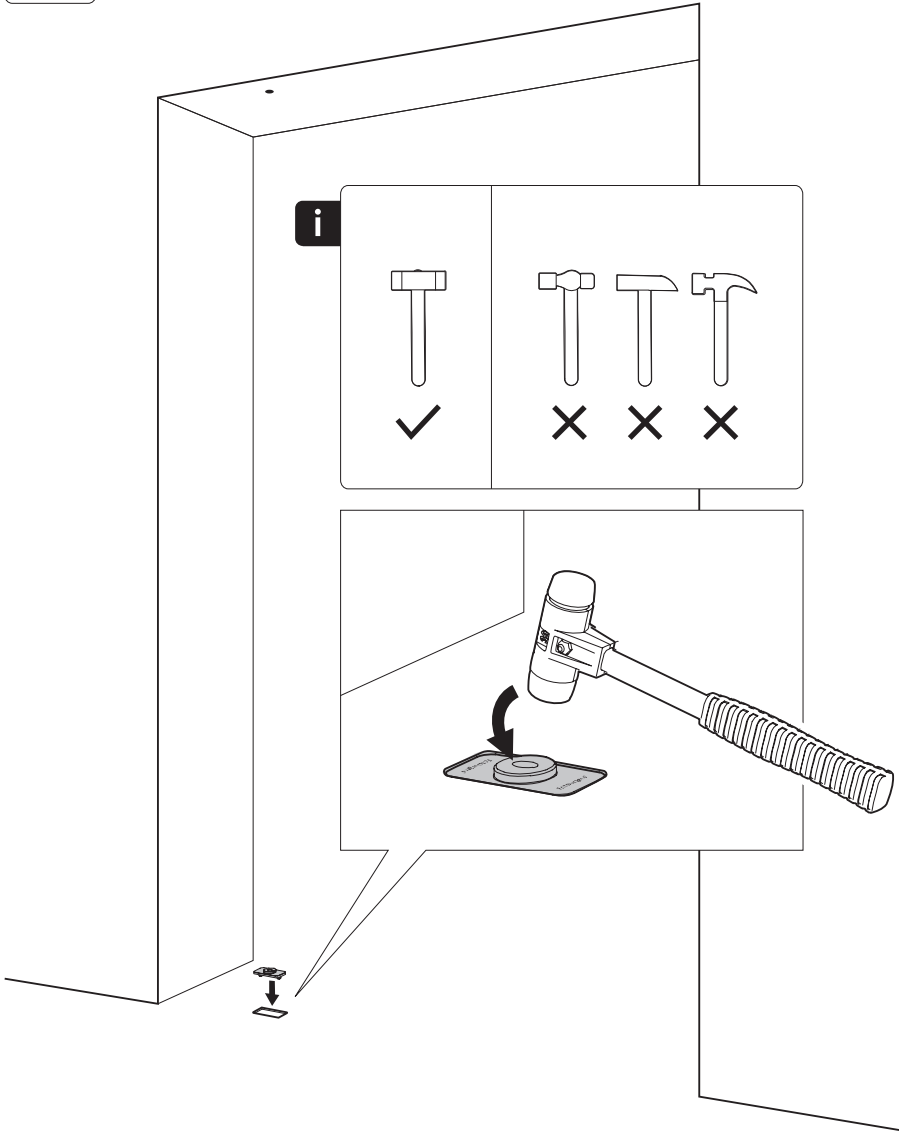



# Mounting instructions

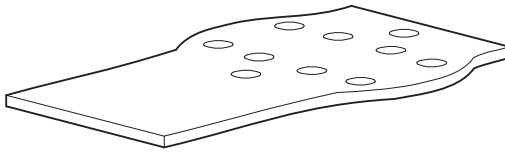

FJ.MT.DT.M



FJ.MT.Z5



FJ.MT.AK3

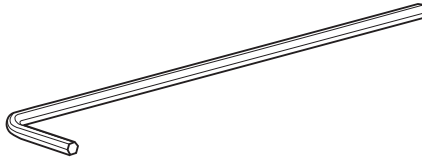

FJ.MT.AK5x24



10x FJ.Tx.4.0x50.PKDD



FJ.Bit.Tx20

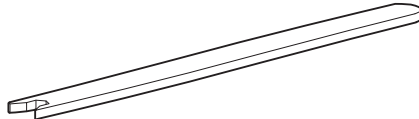

FJ.MT.AS.M

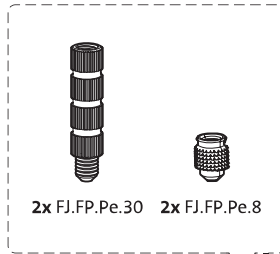

2x FJ.FP.Pe.30 2x FJ.FP.Pe.8

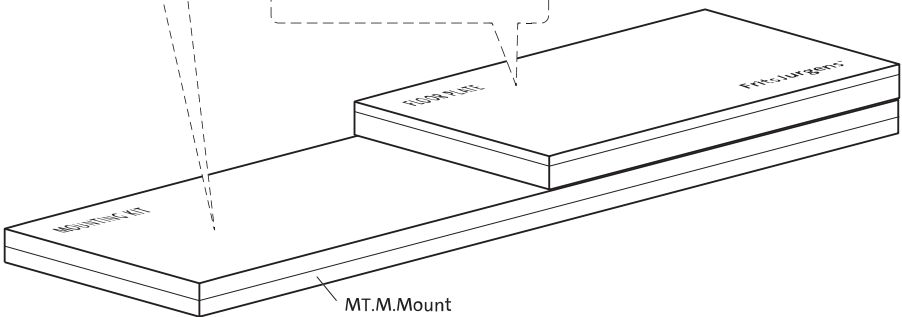

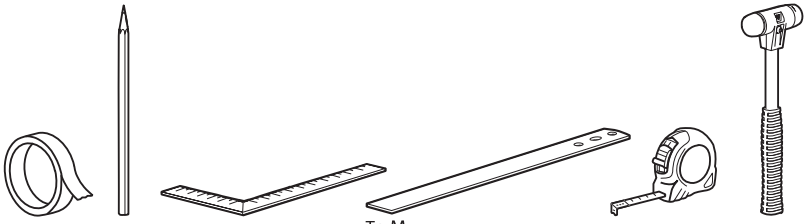

To.M

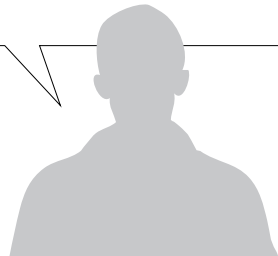
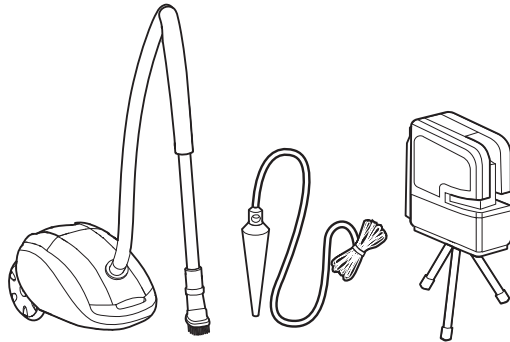
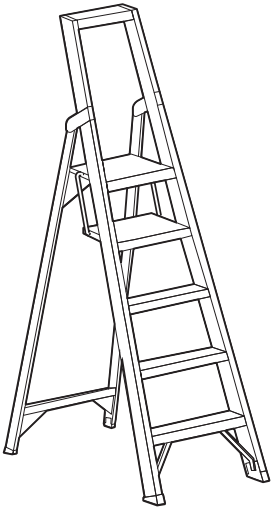
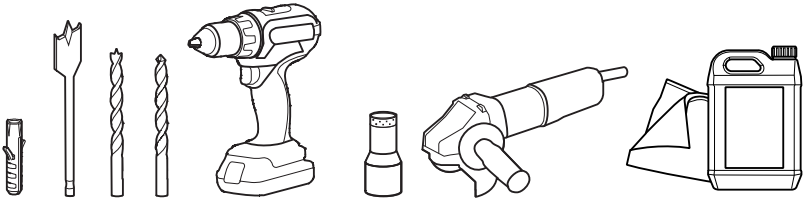

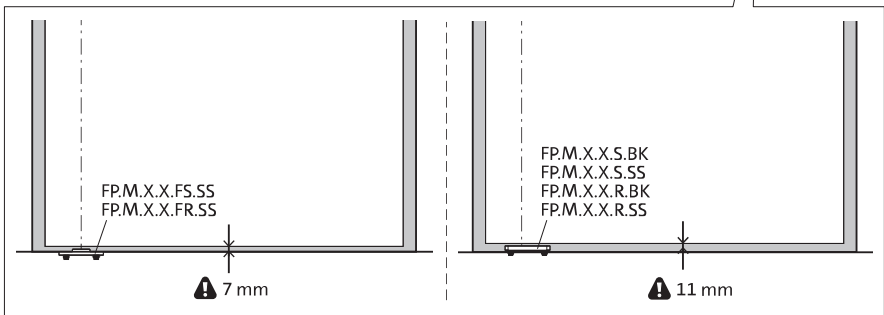
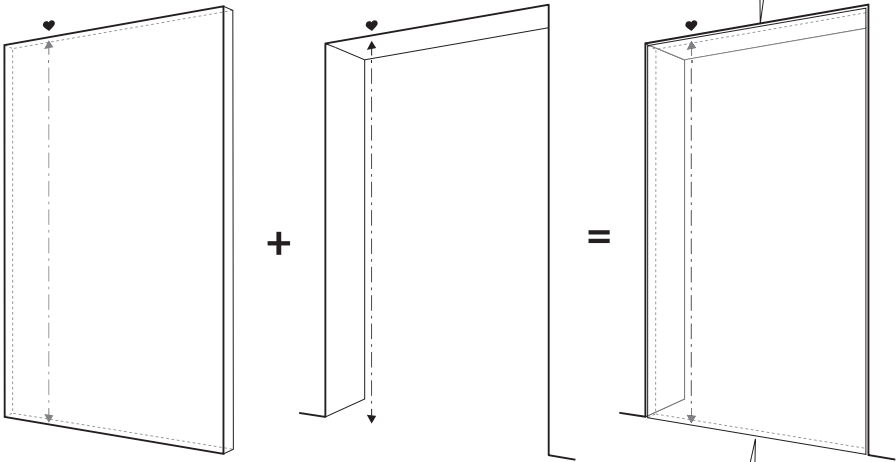
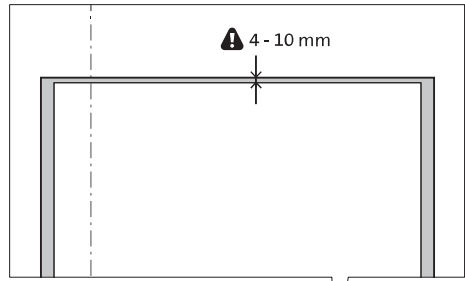

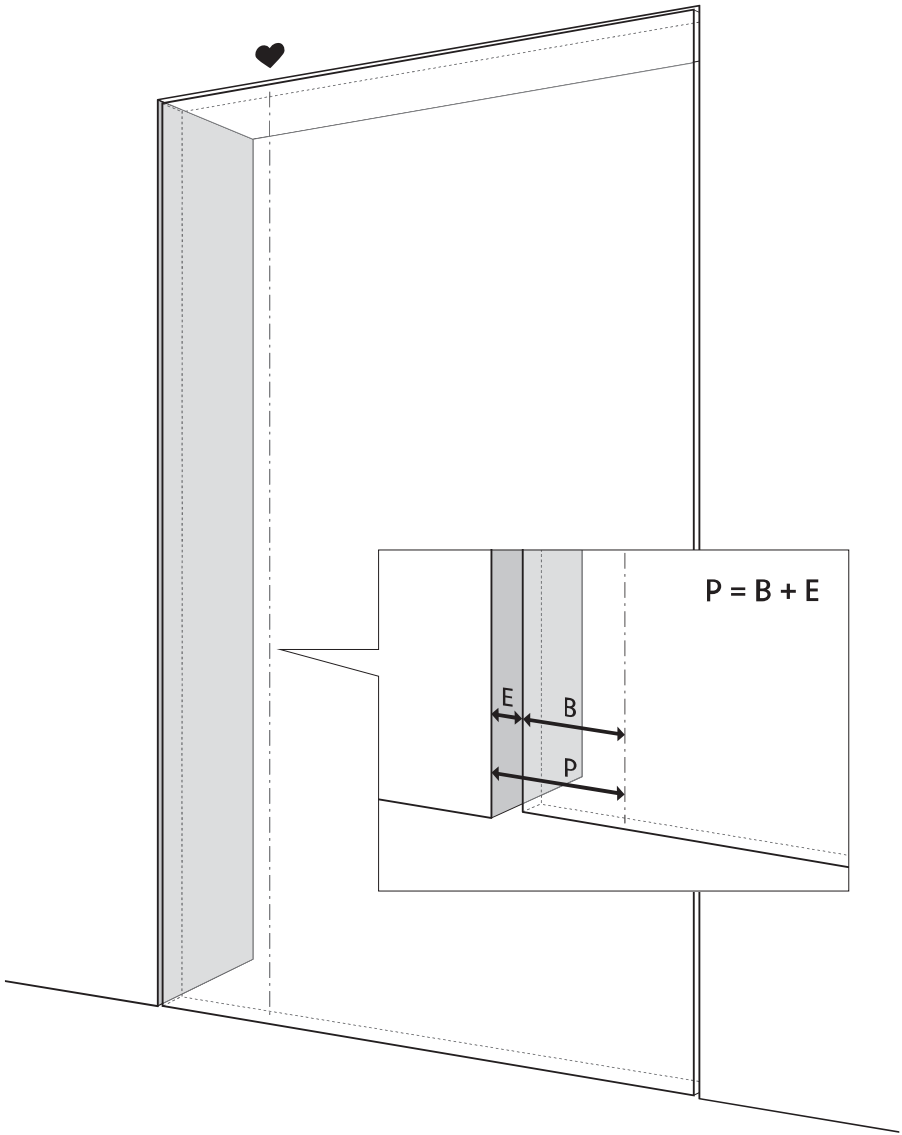

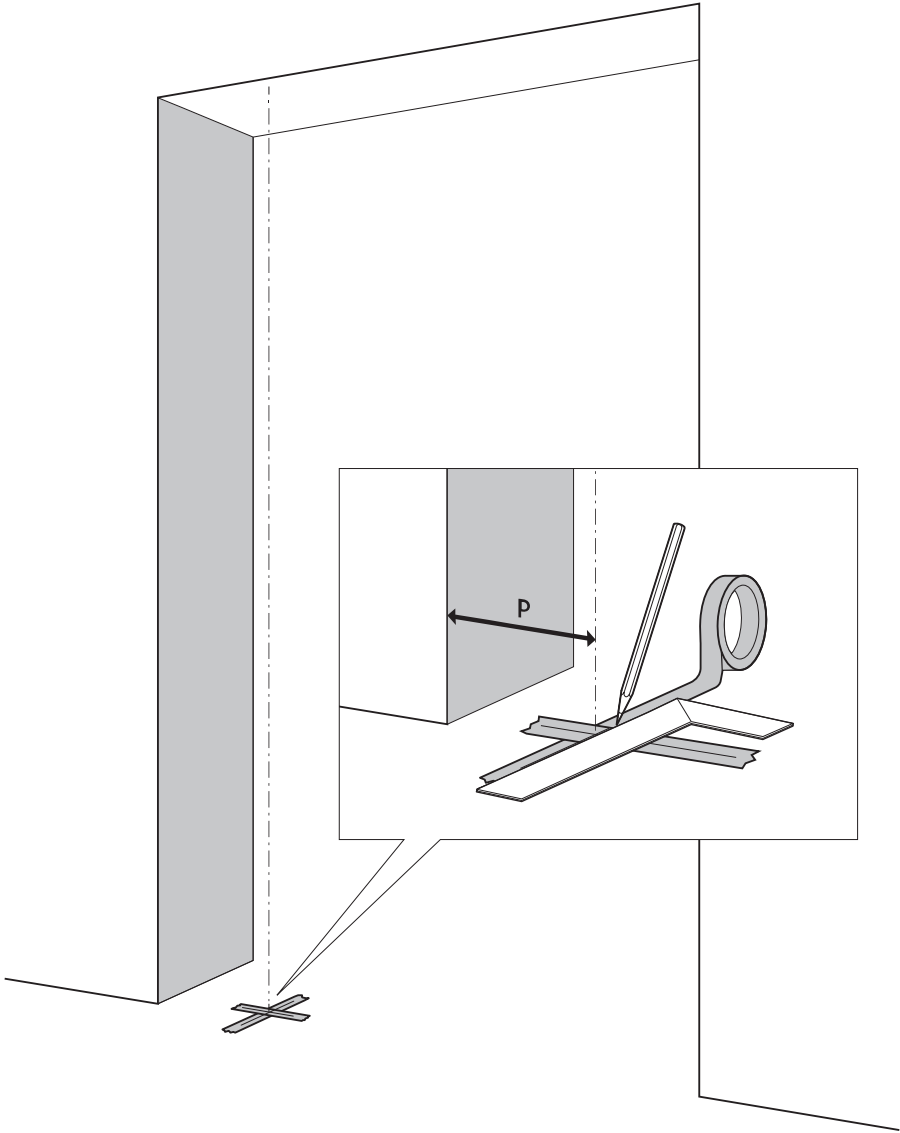



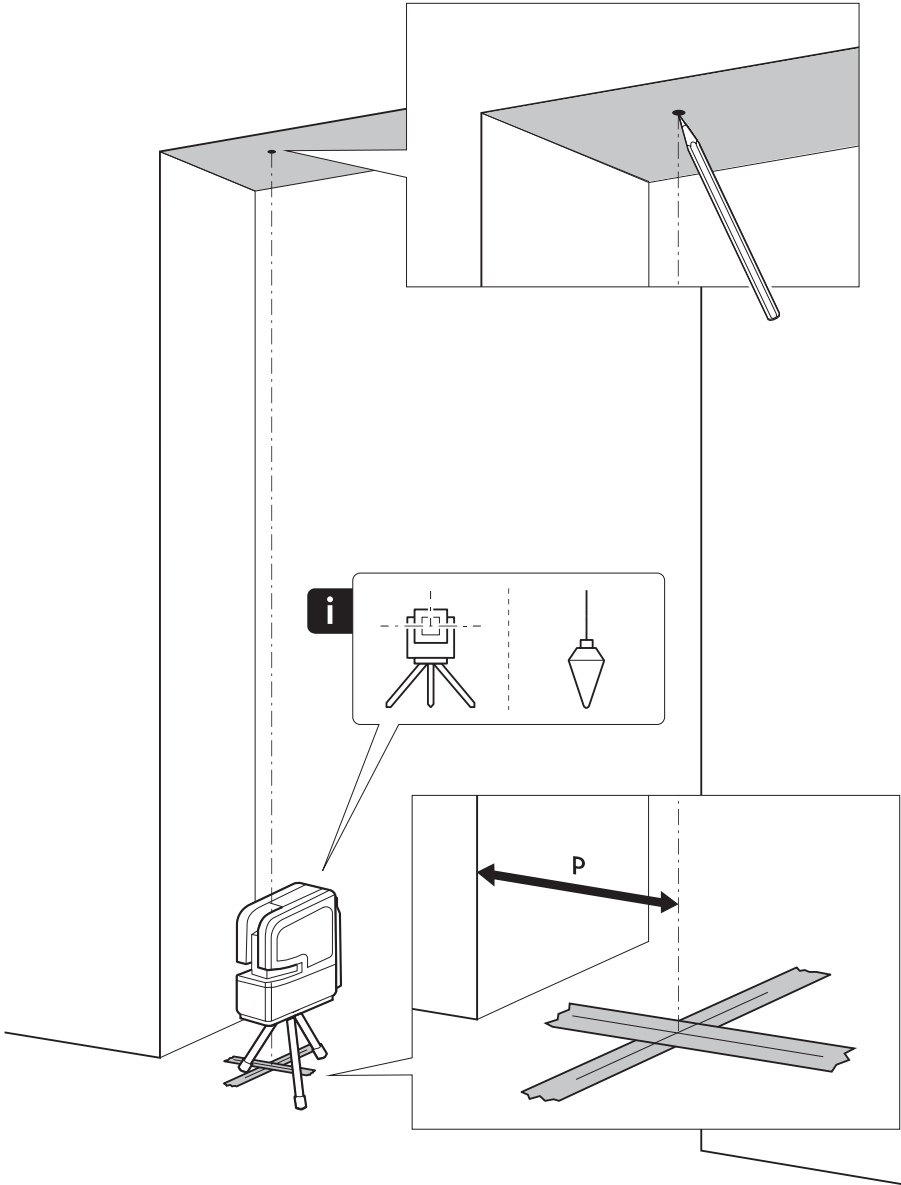
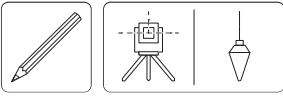

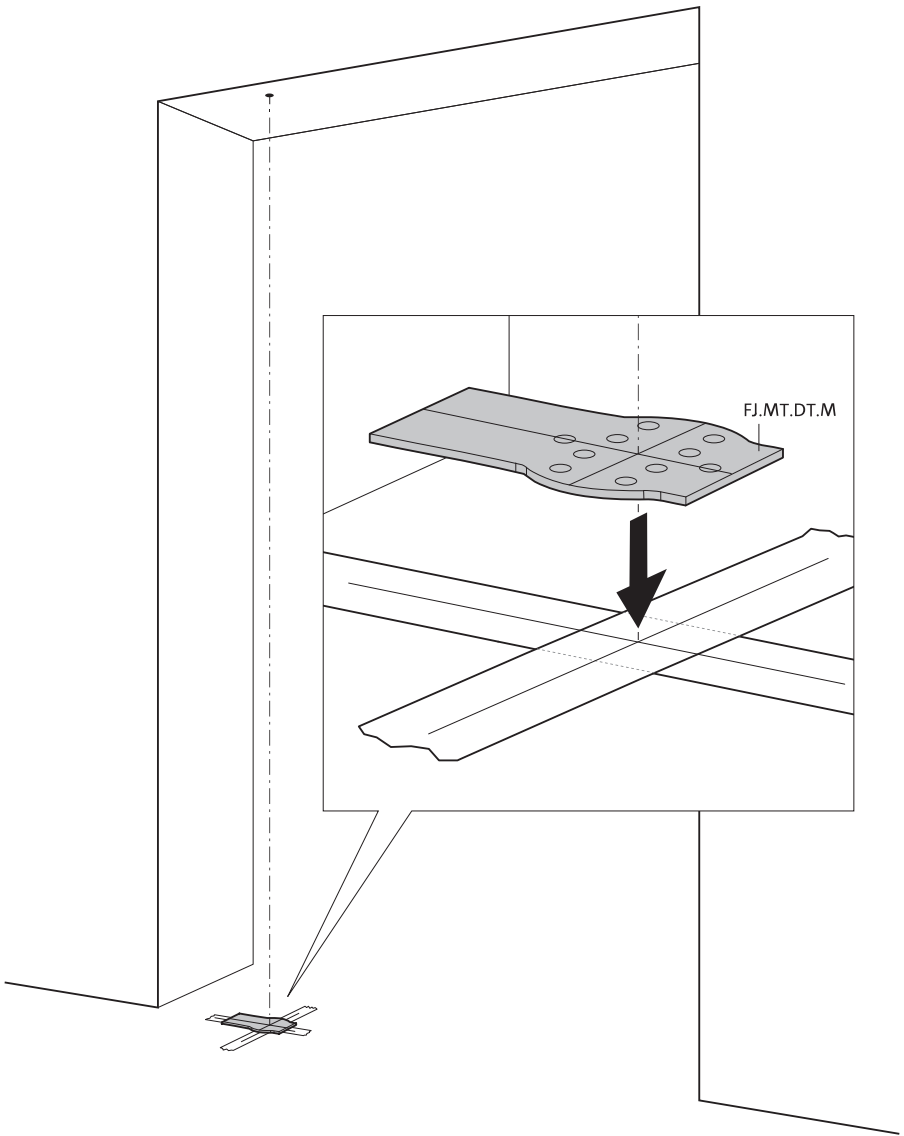

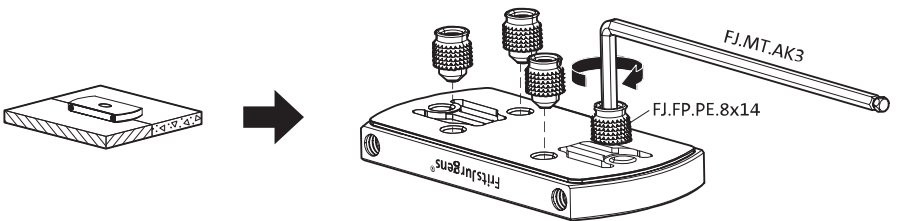
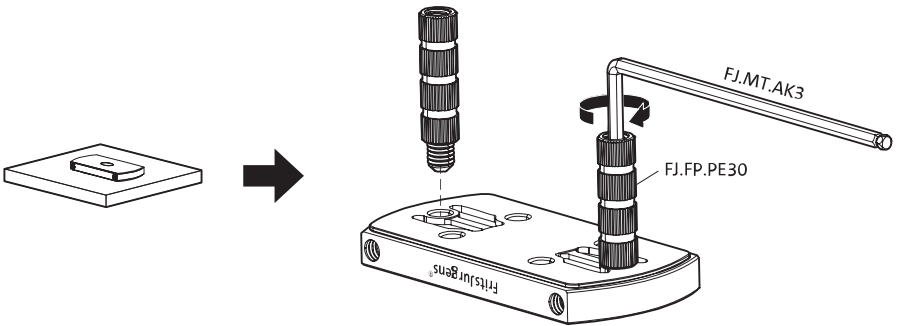
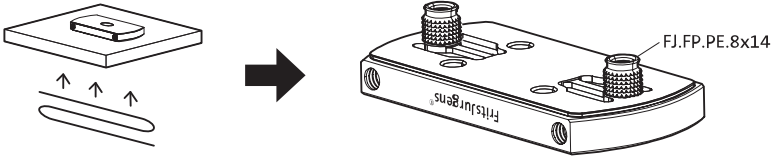



ø8 mm (5/16")

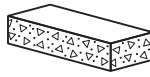

ø8 mm (5/16")

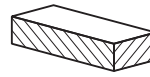

ø7.5 mm (19/64")

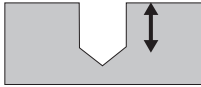

8 mm (5/16")



8 mm (5/16")

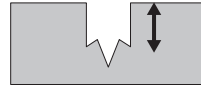

8 mm (5/16")

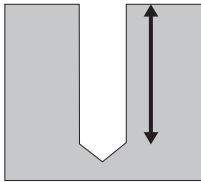

30 mm (13/16")

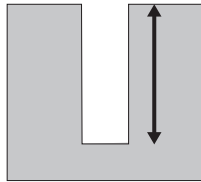

30 mm (13/16")

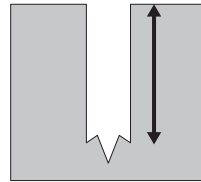

30 mm (13/16")

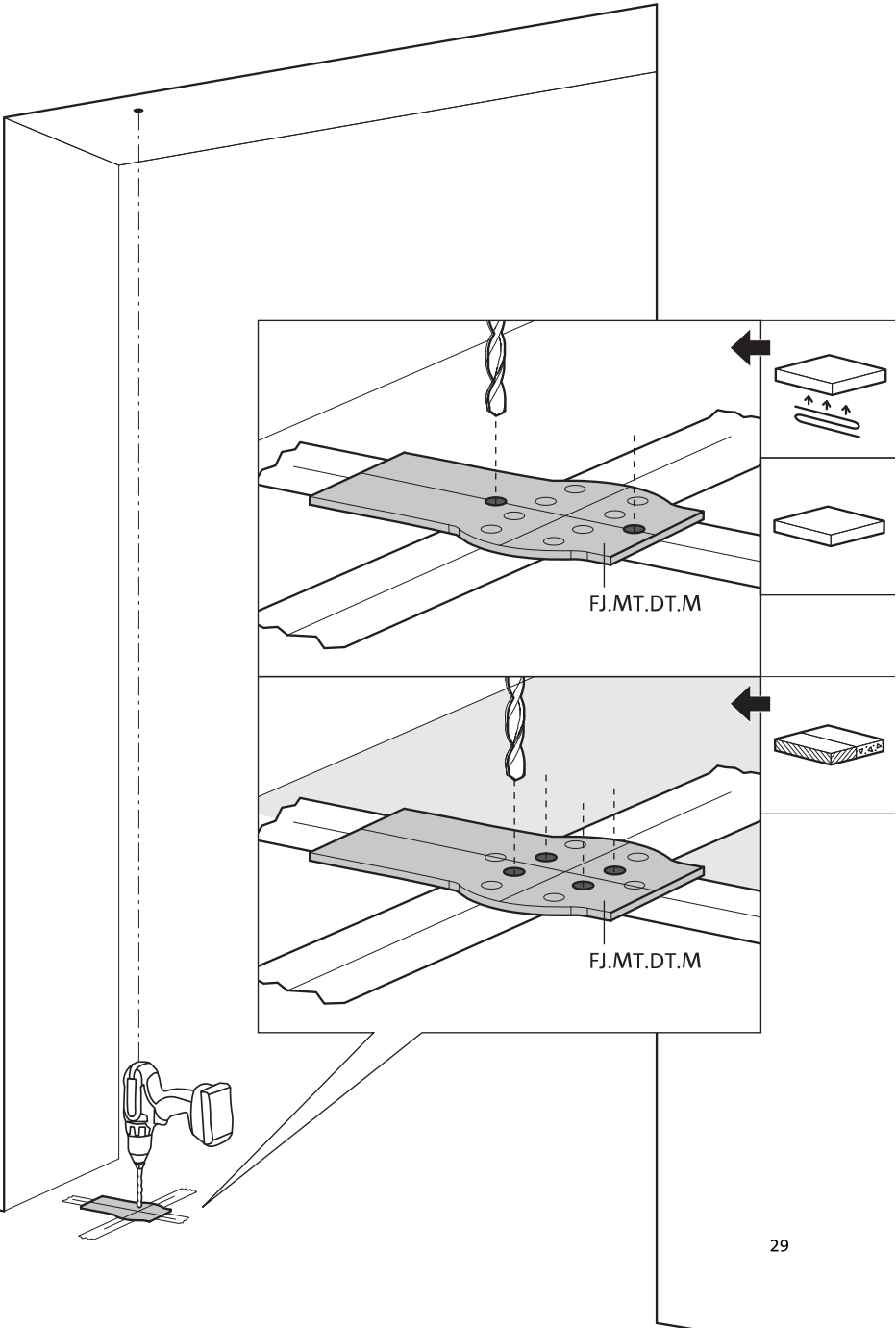

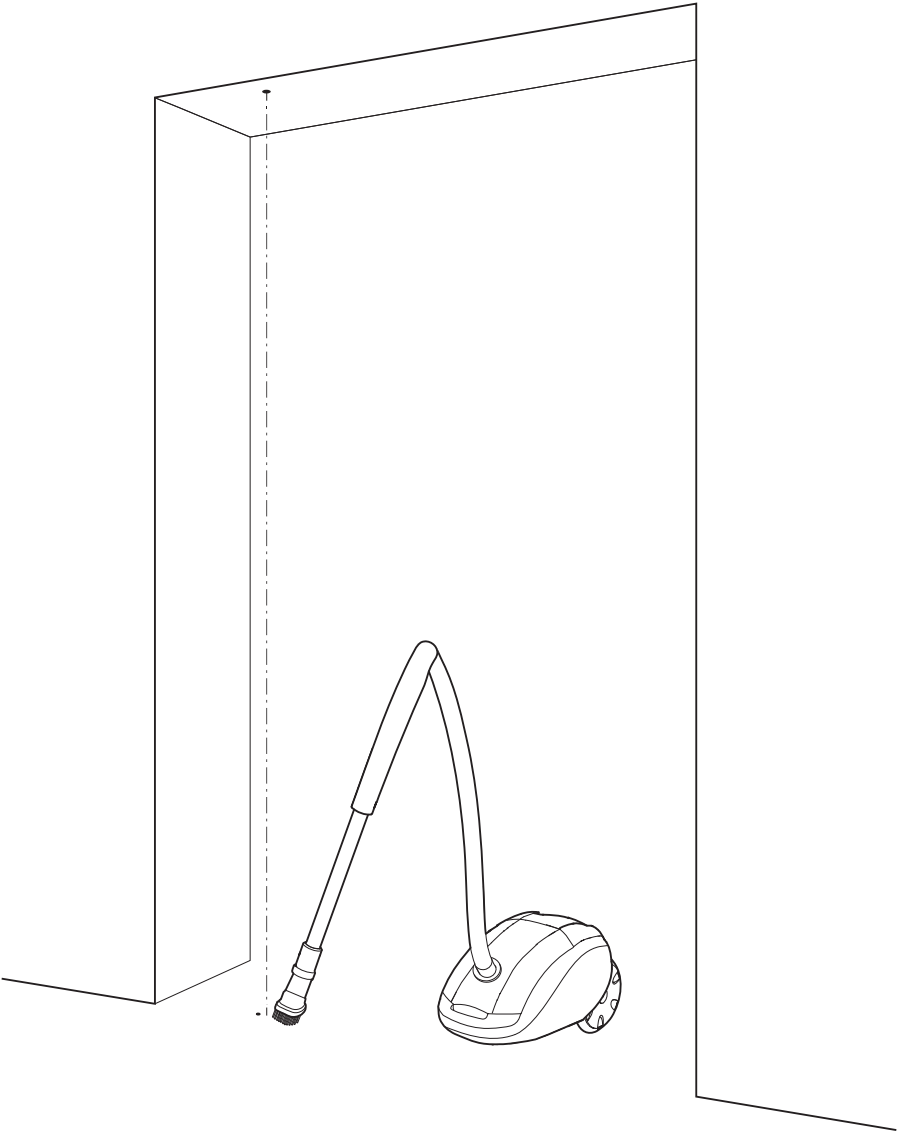



1

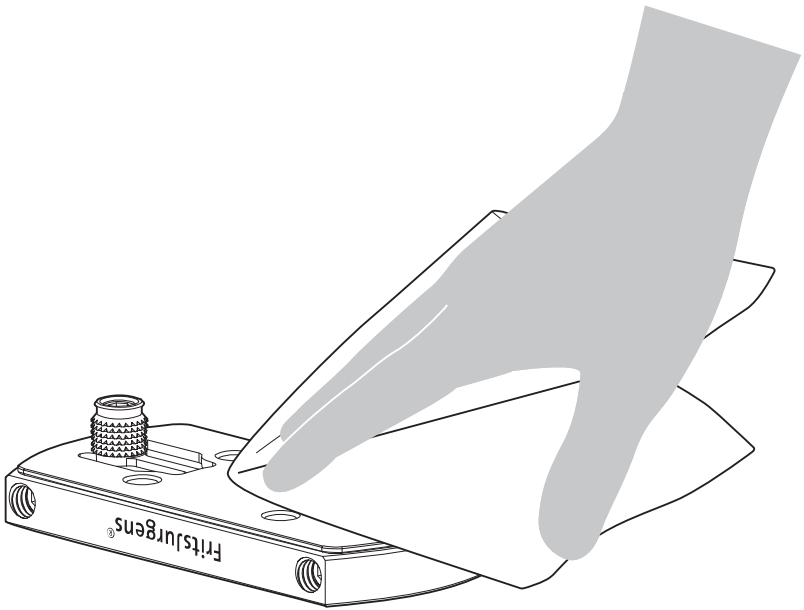

2

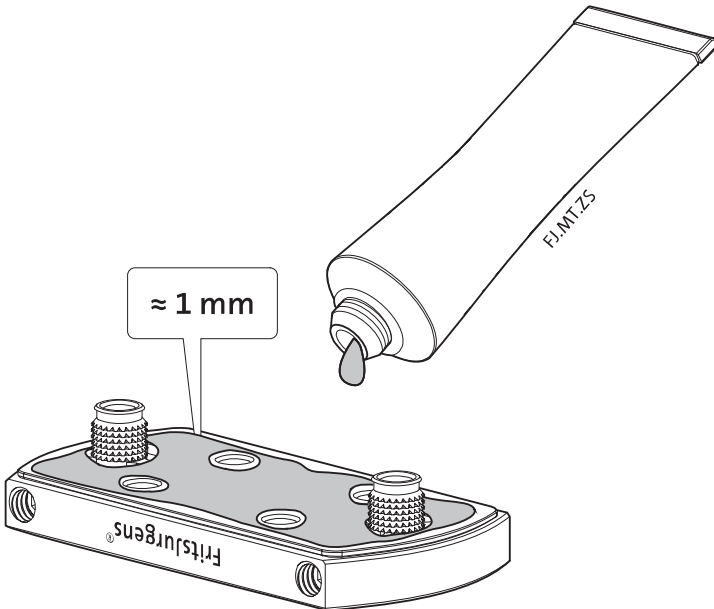

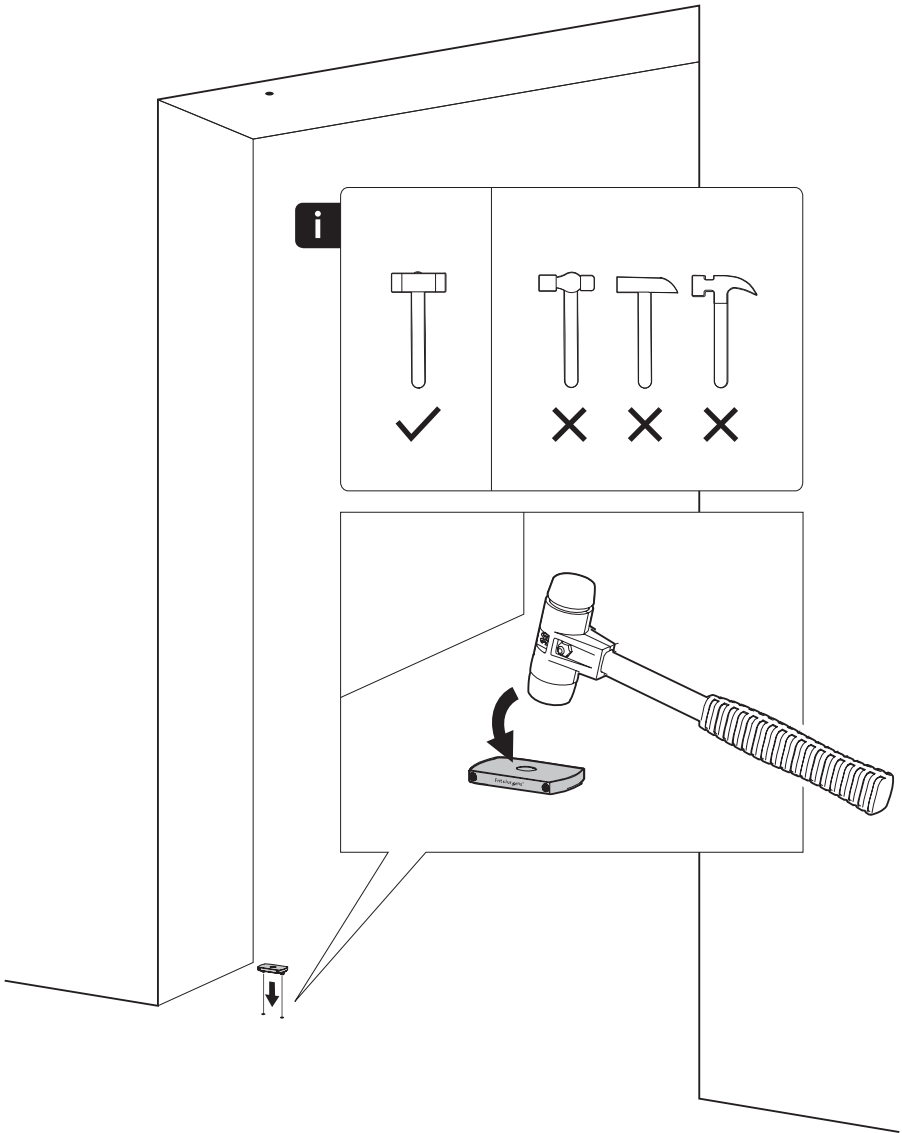



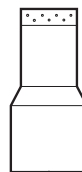
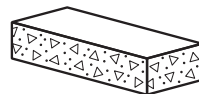
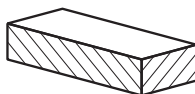
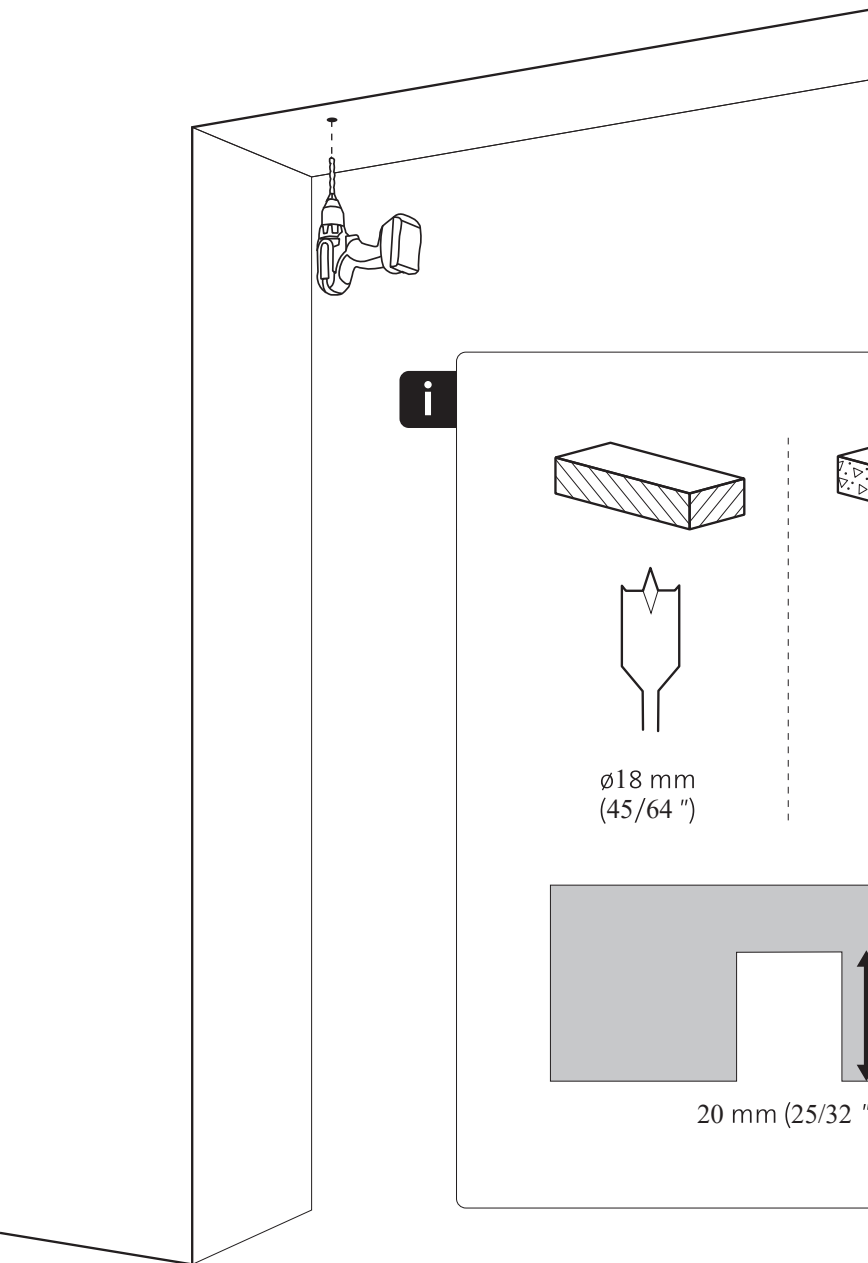
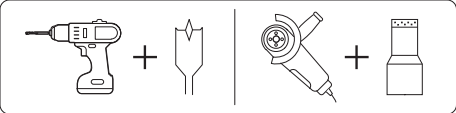

ø18 mm  
(45/64 ")

ø18 mm  
(45/64 ")

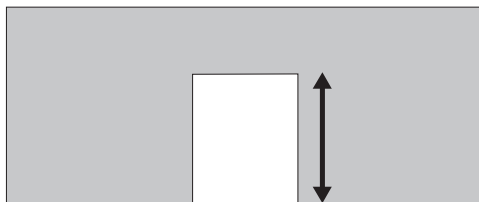

20 mm (25/32 ")





1

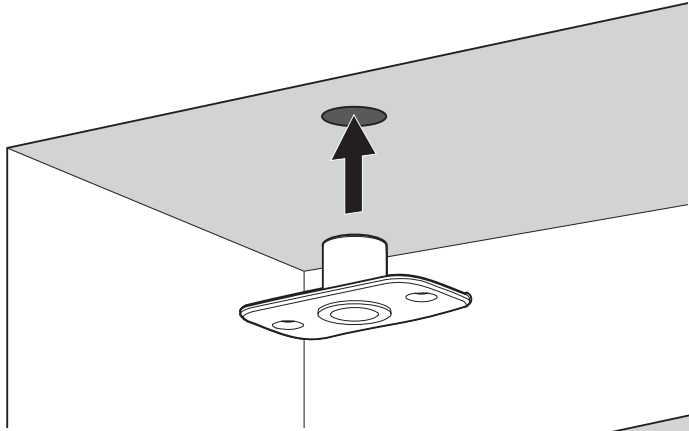

2

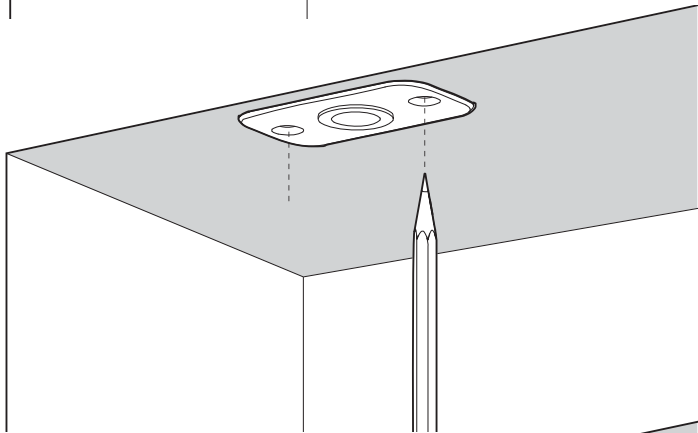

3

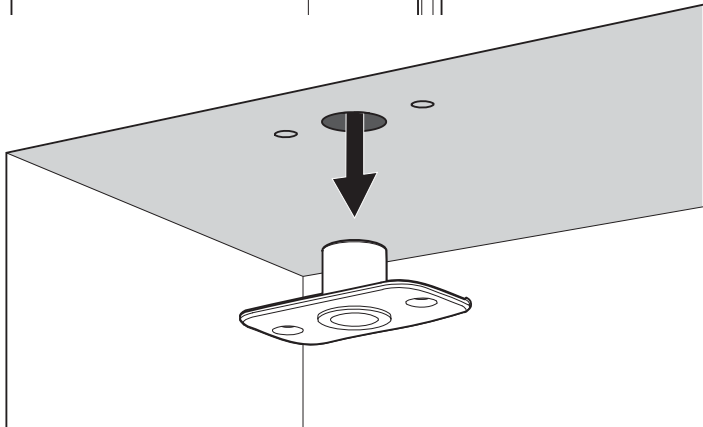



1

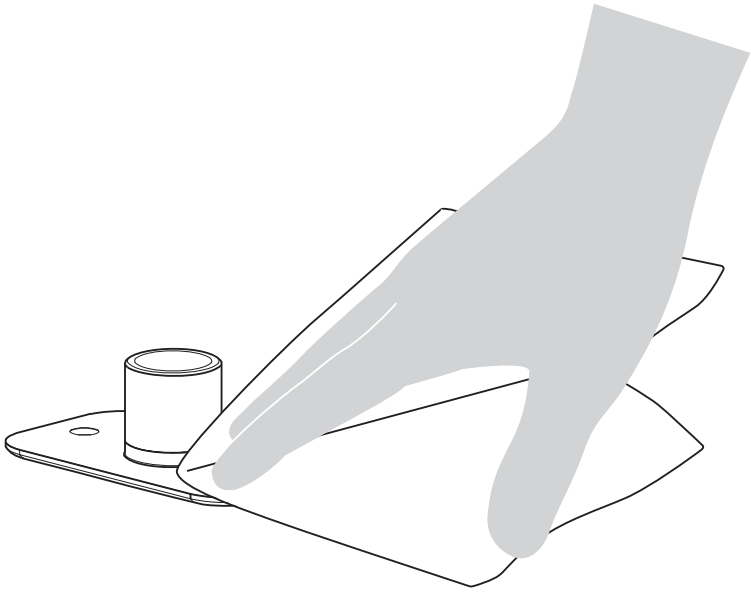

2

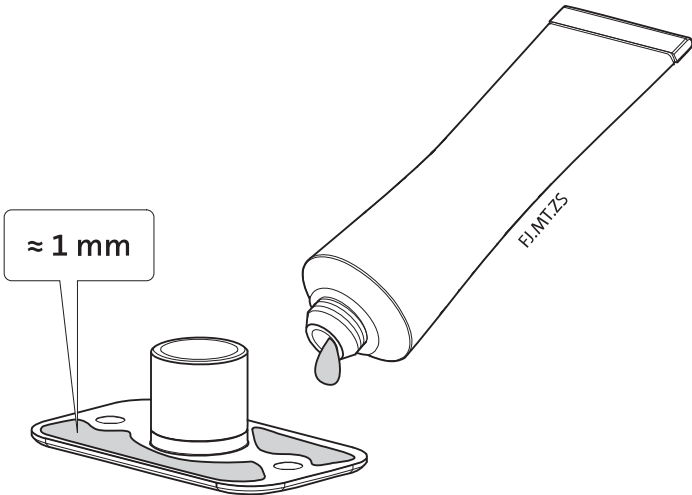

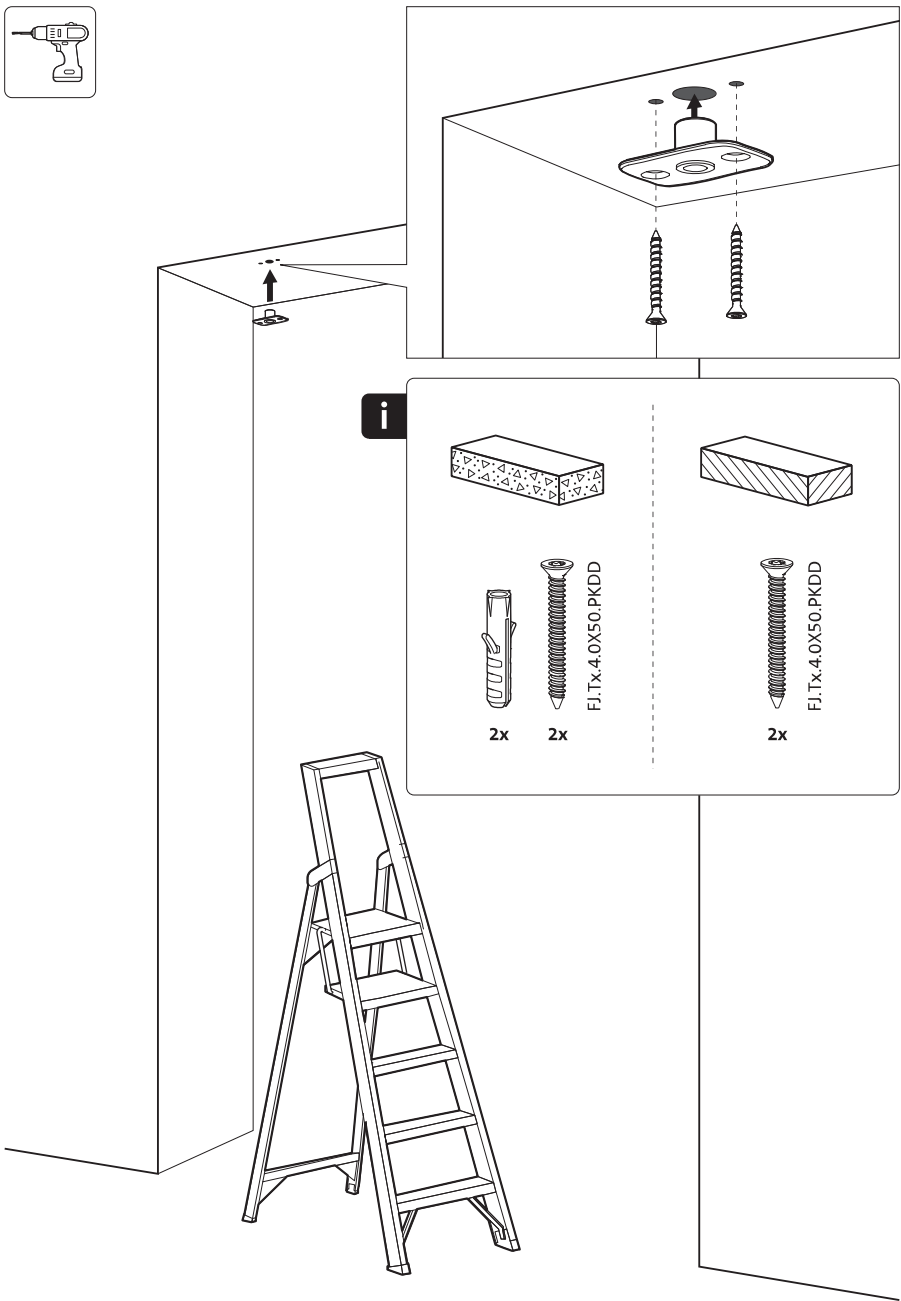

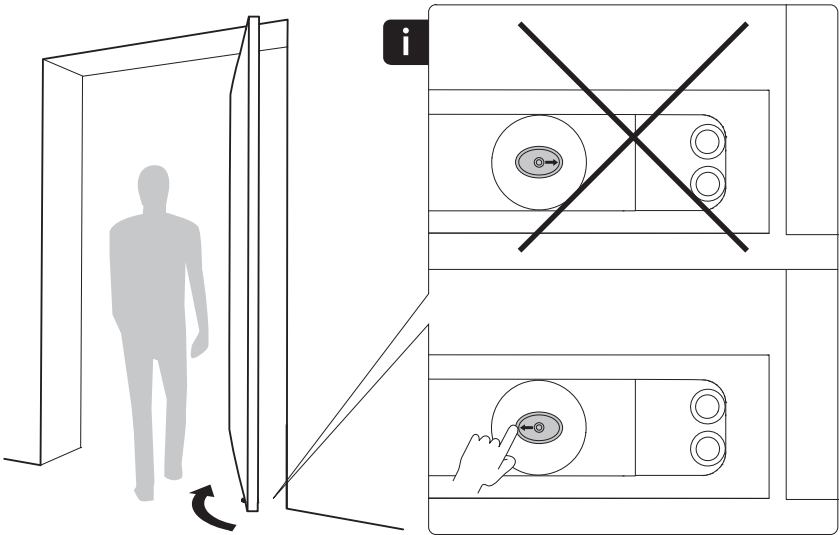
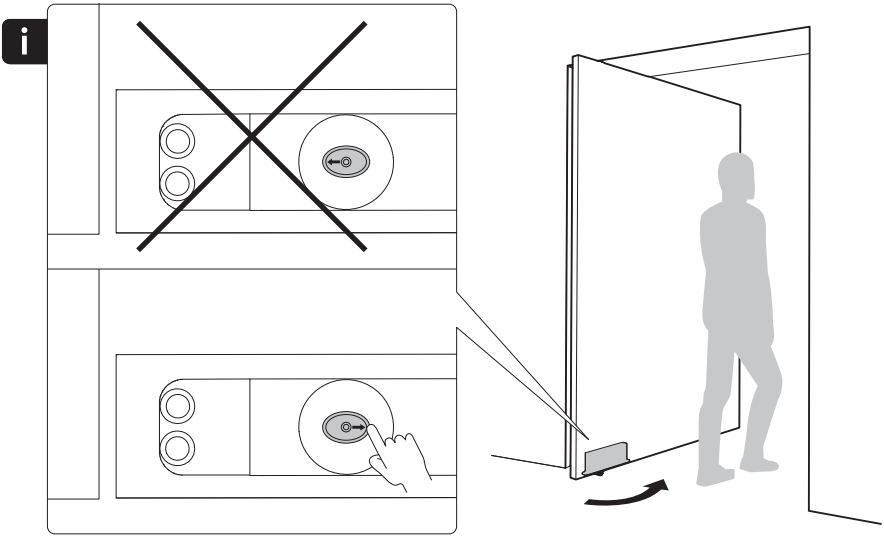

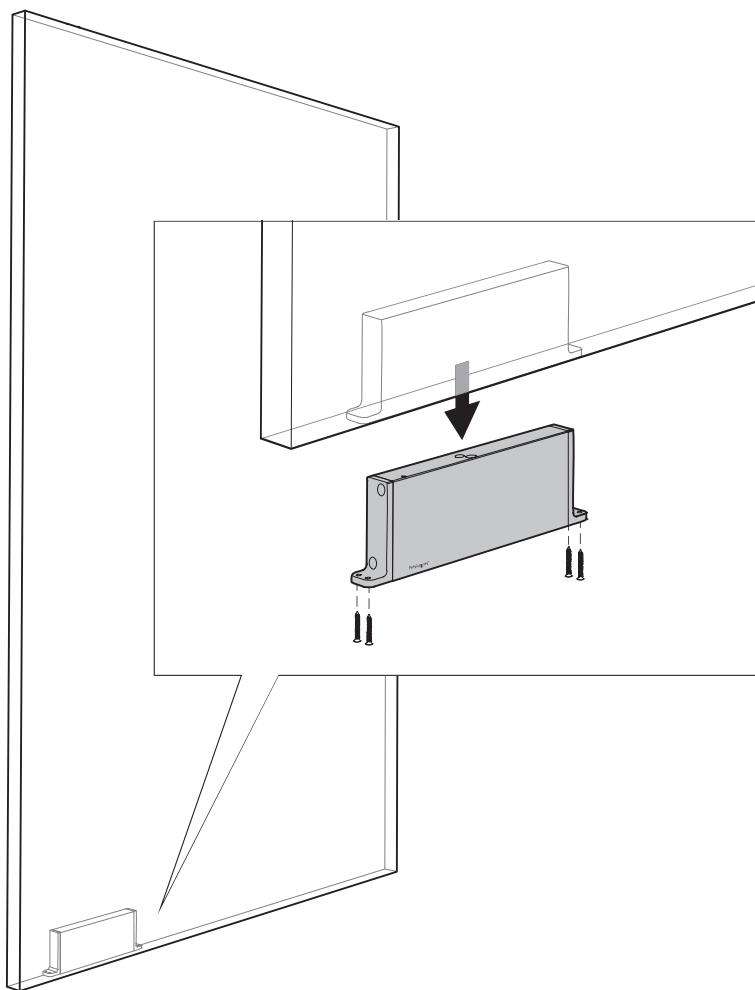

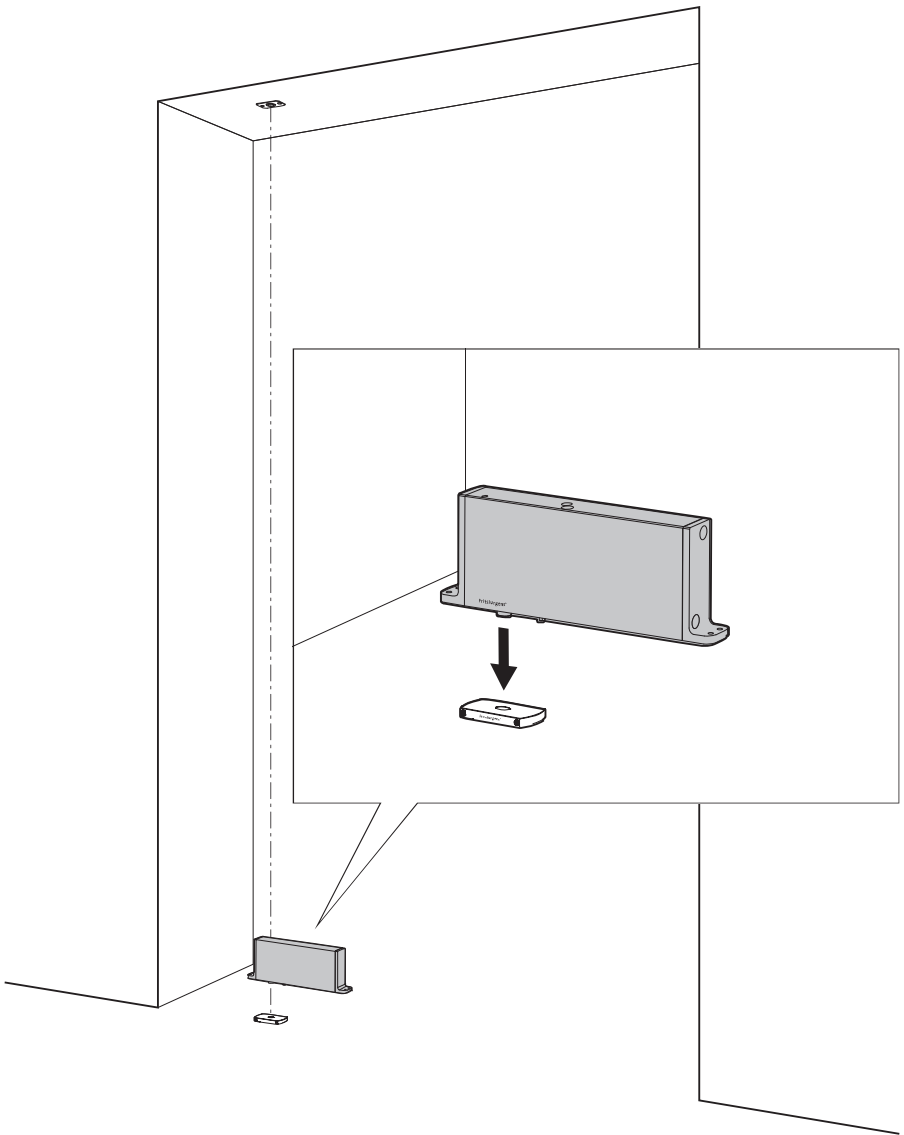

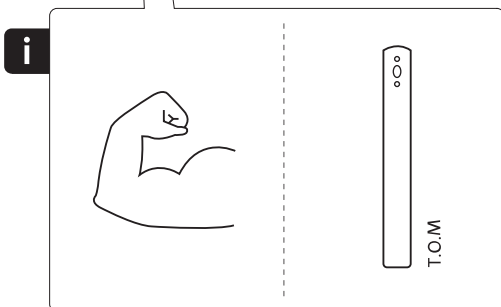
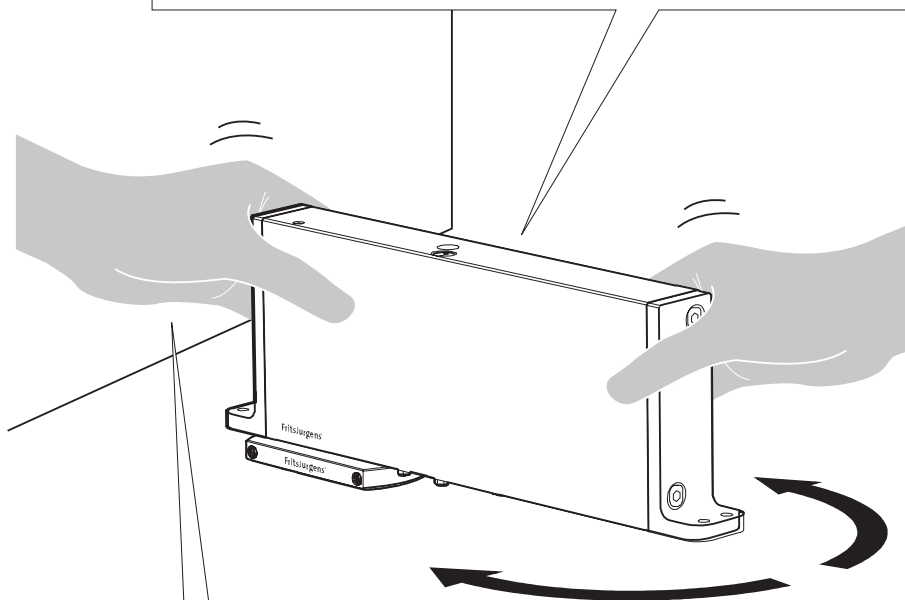
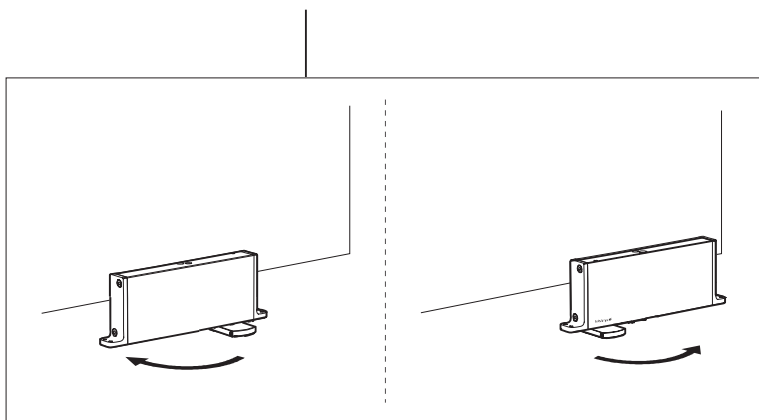



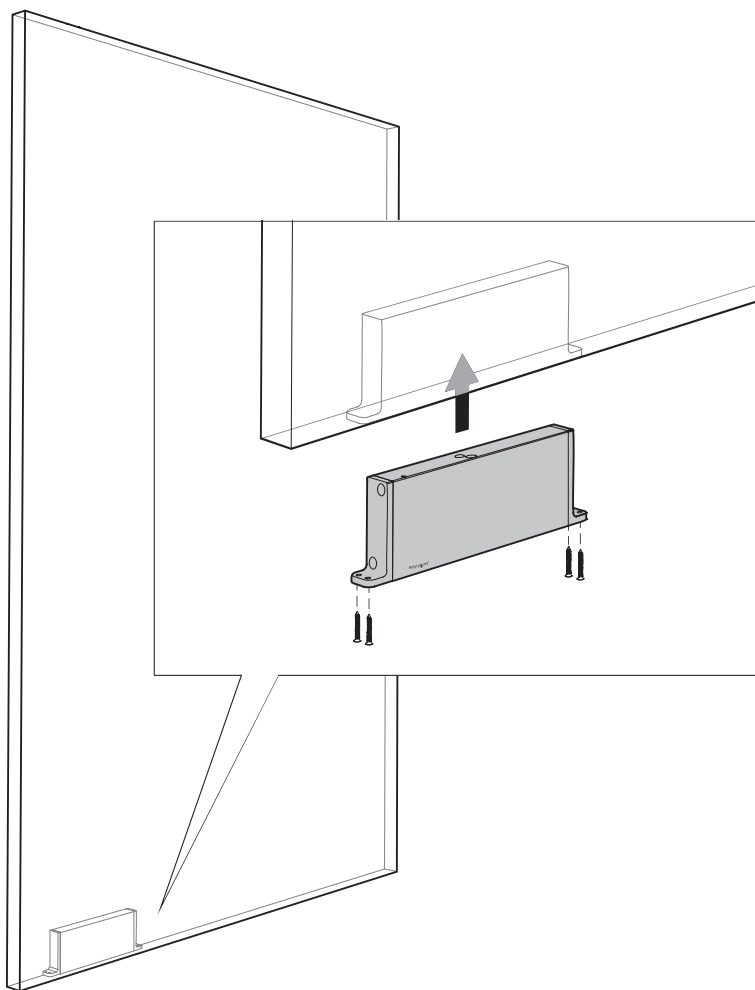

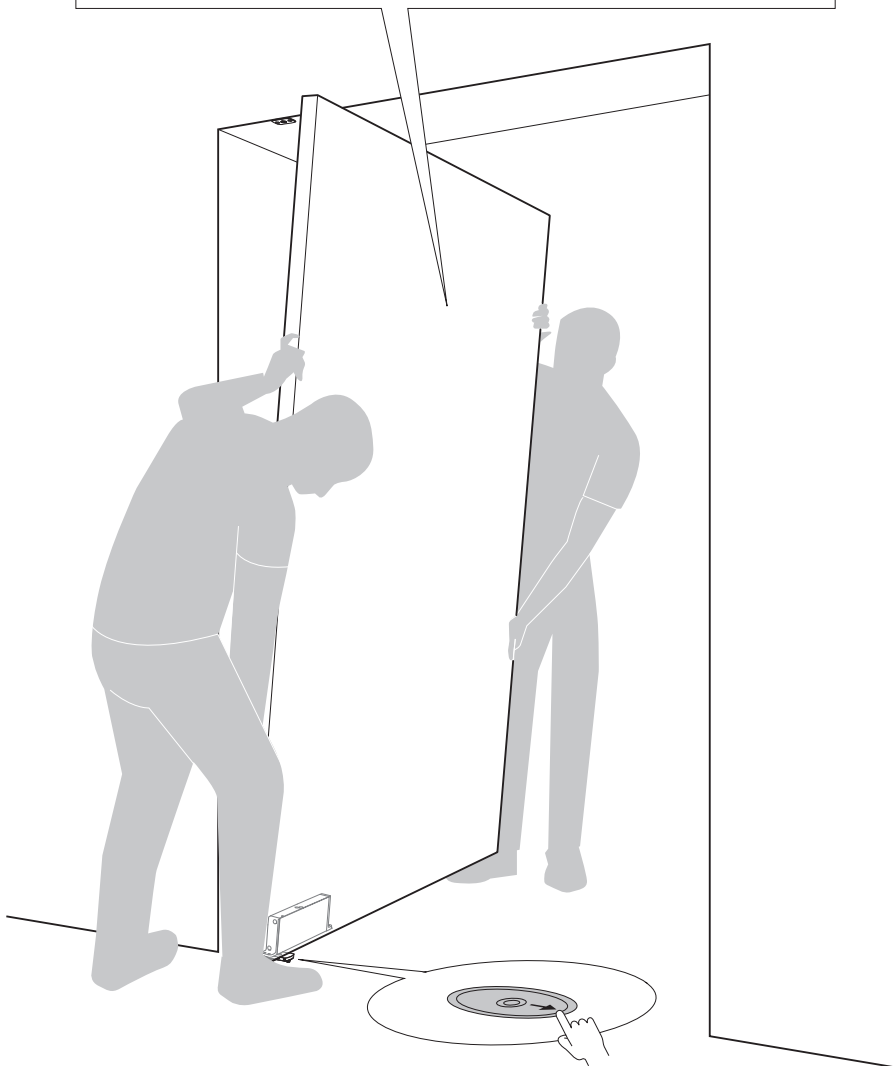
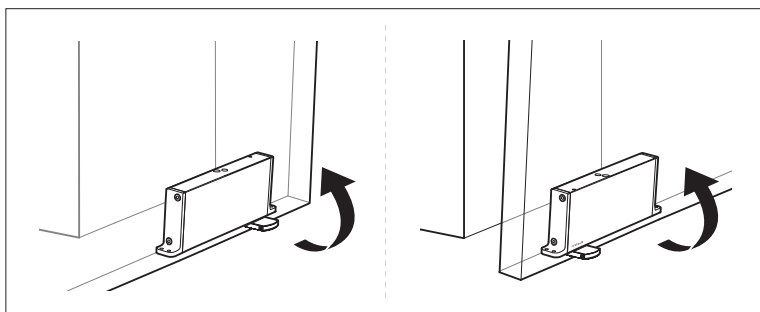

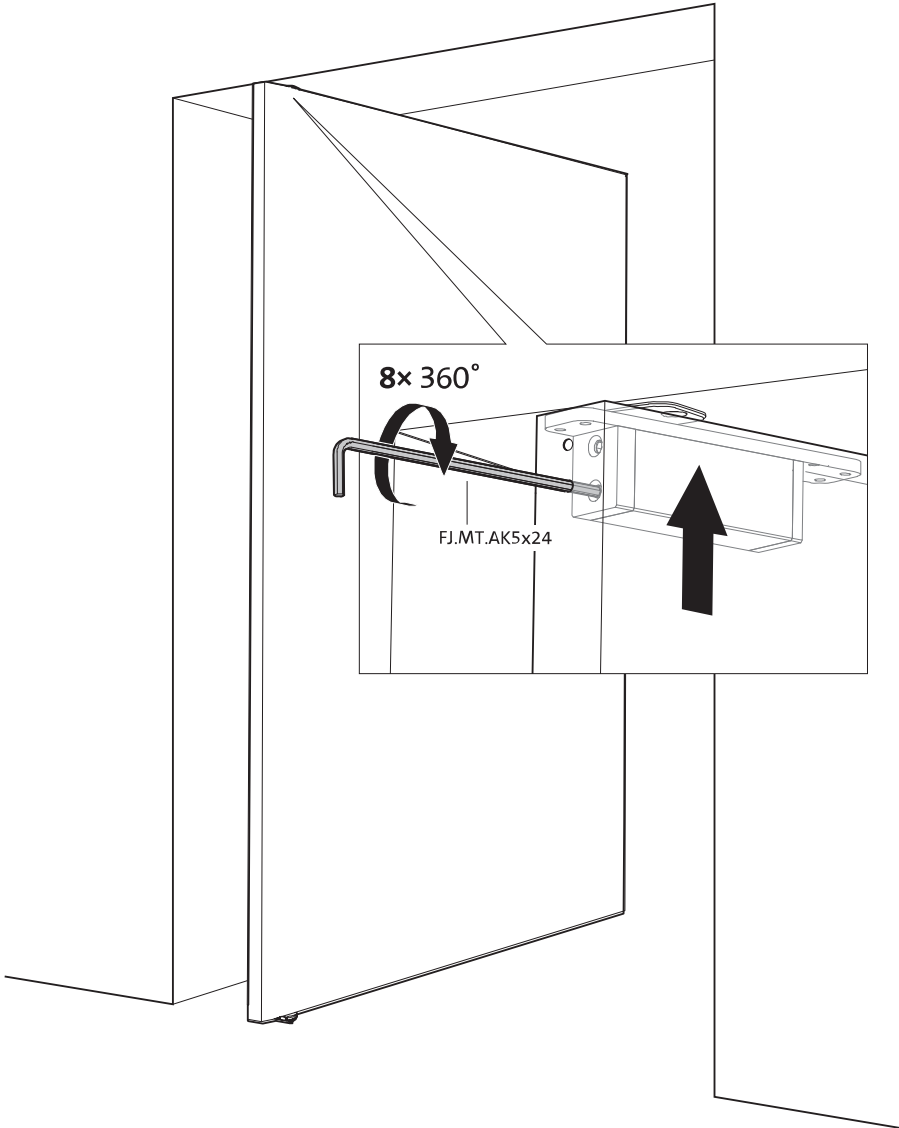
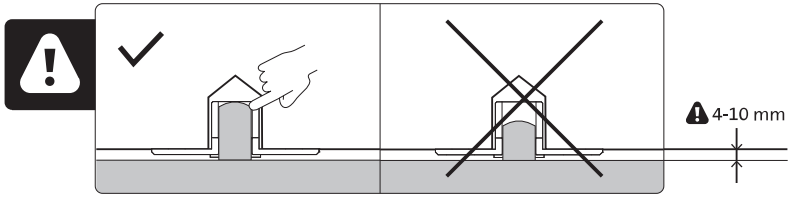

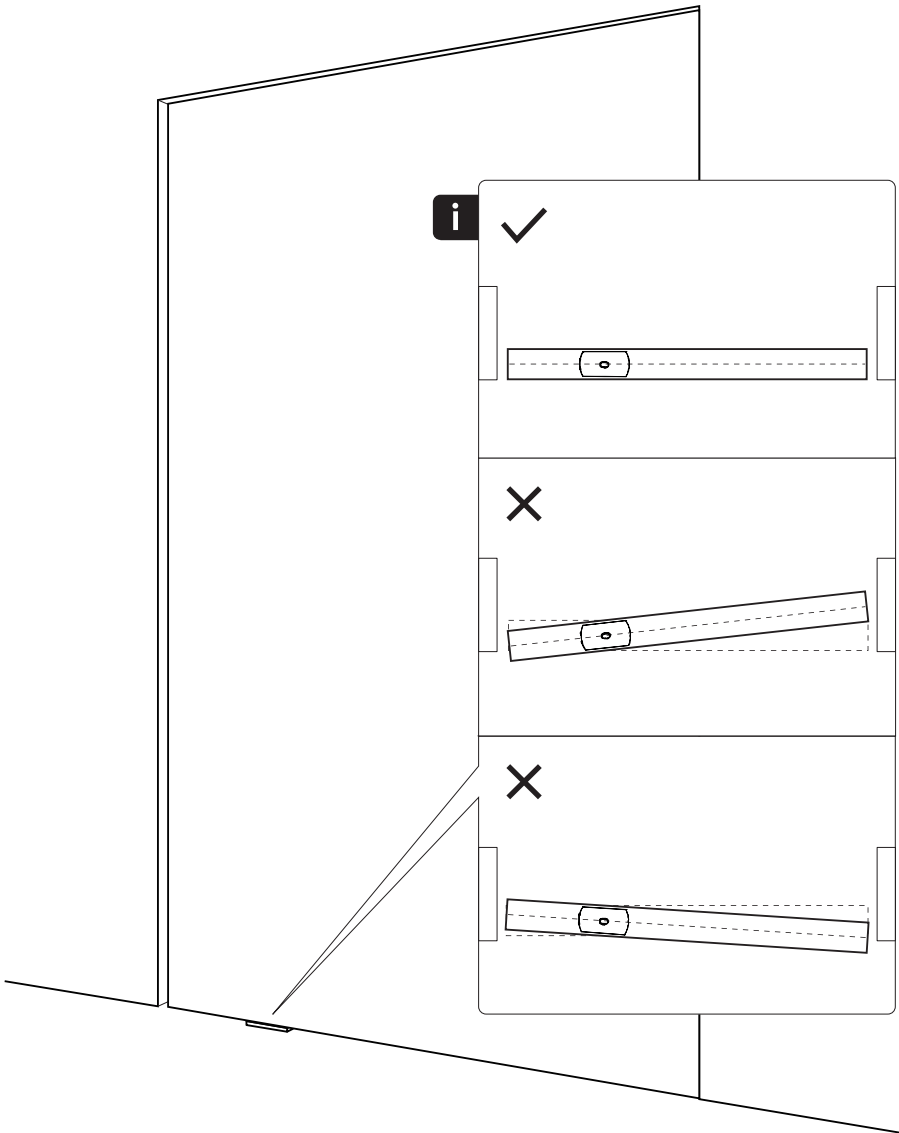

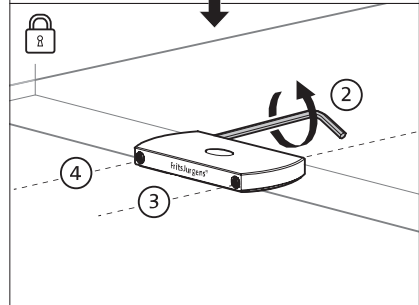
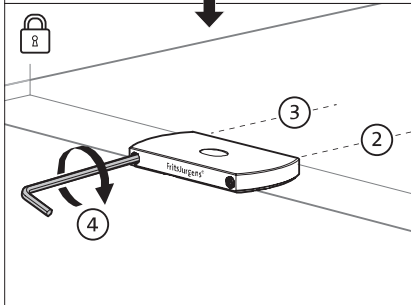
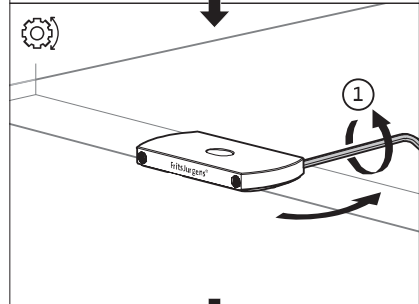
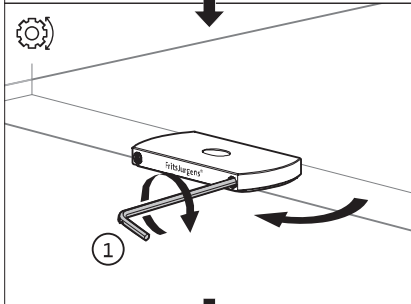
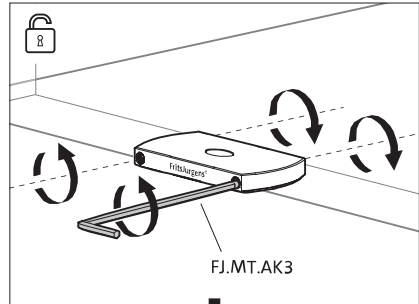
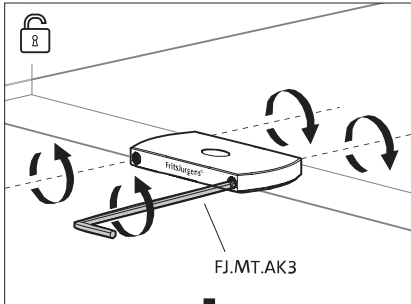
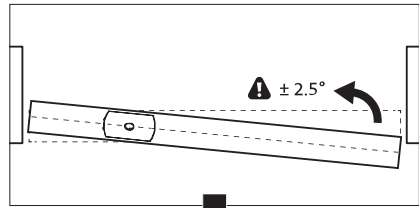
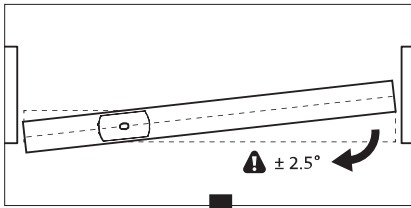

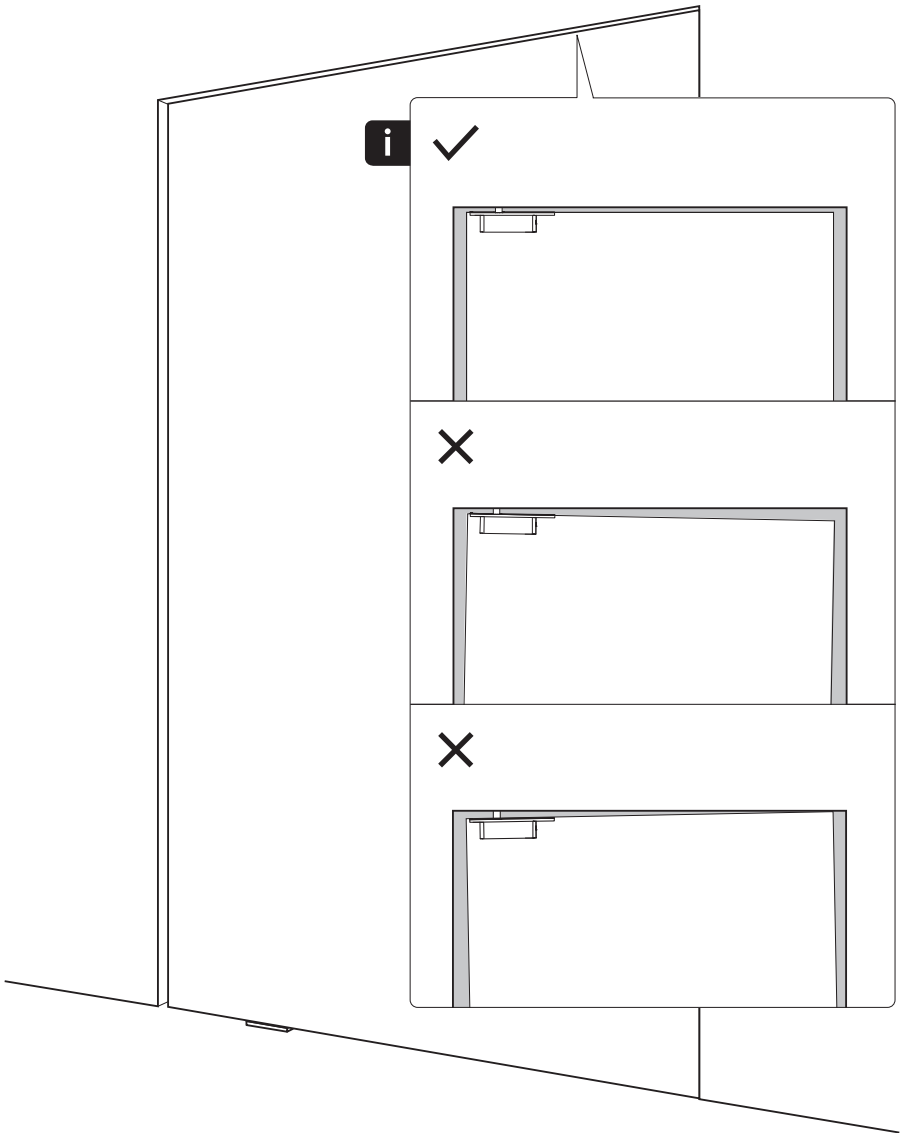

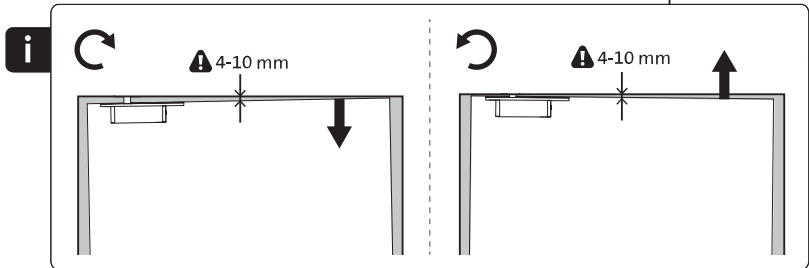
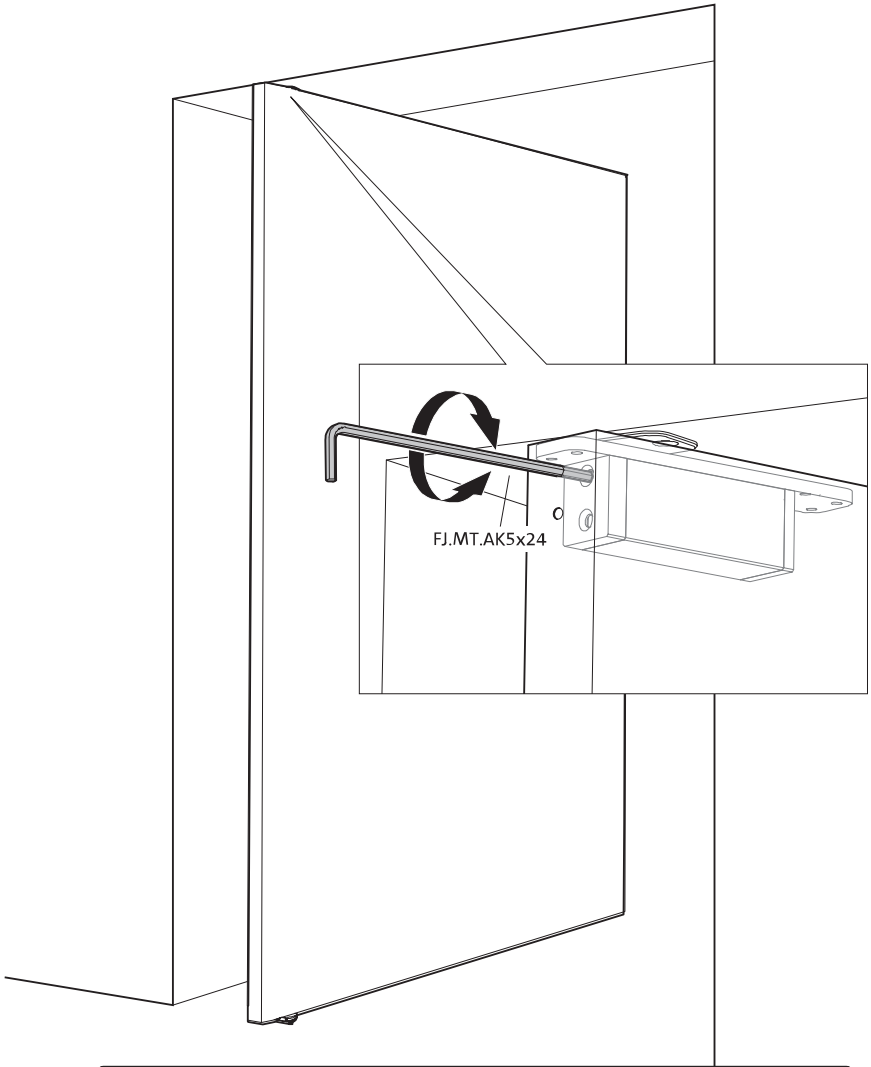

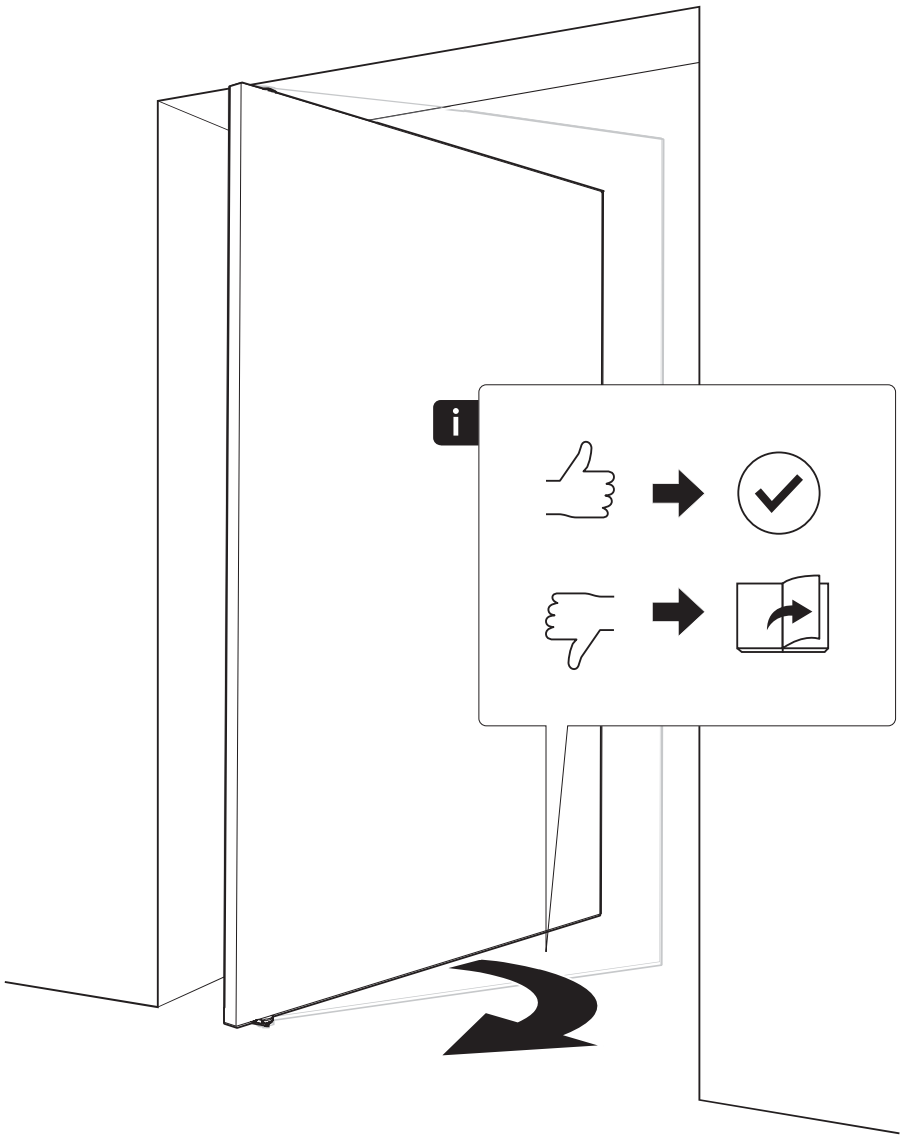



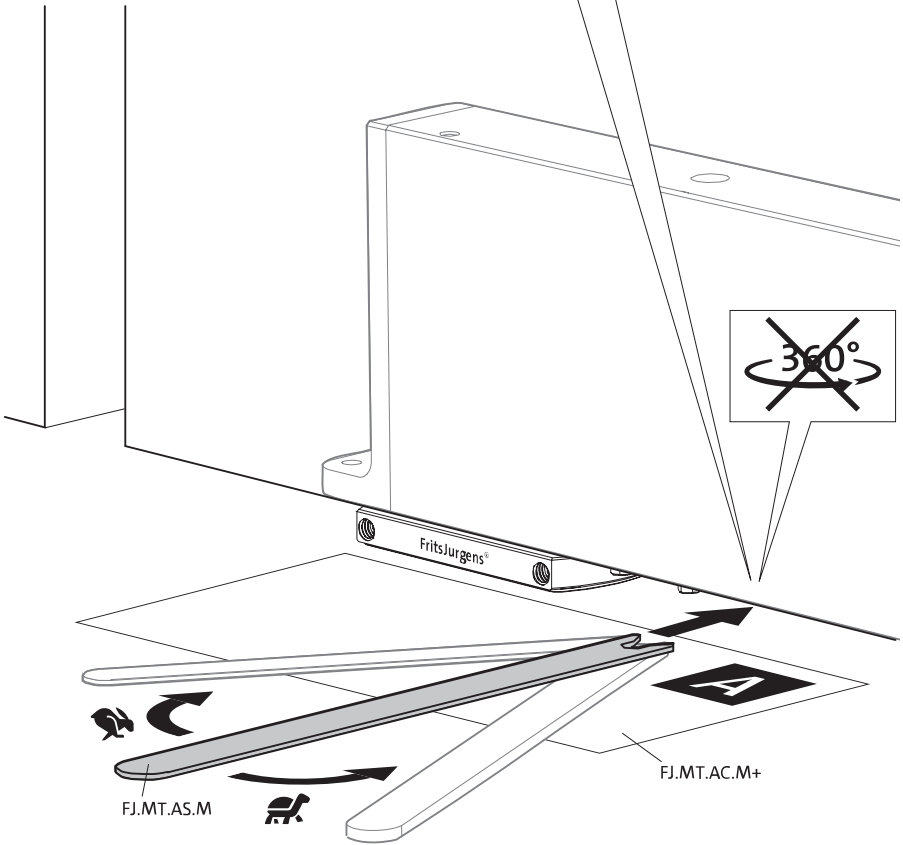
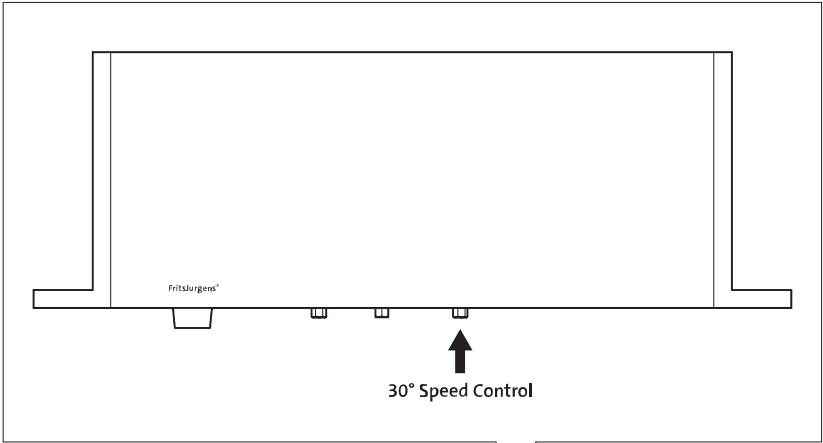



# Disassembly instructions

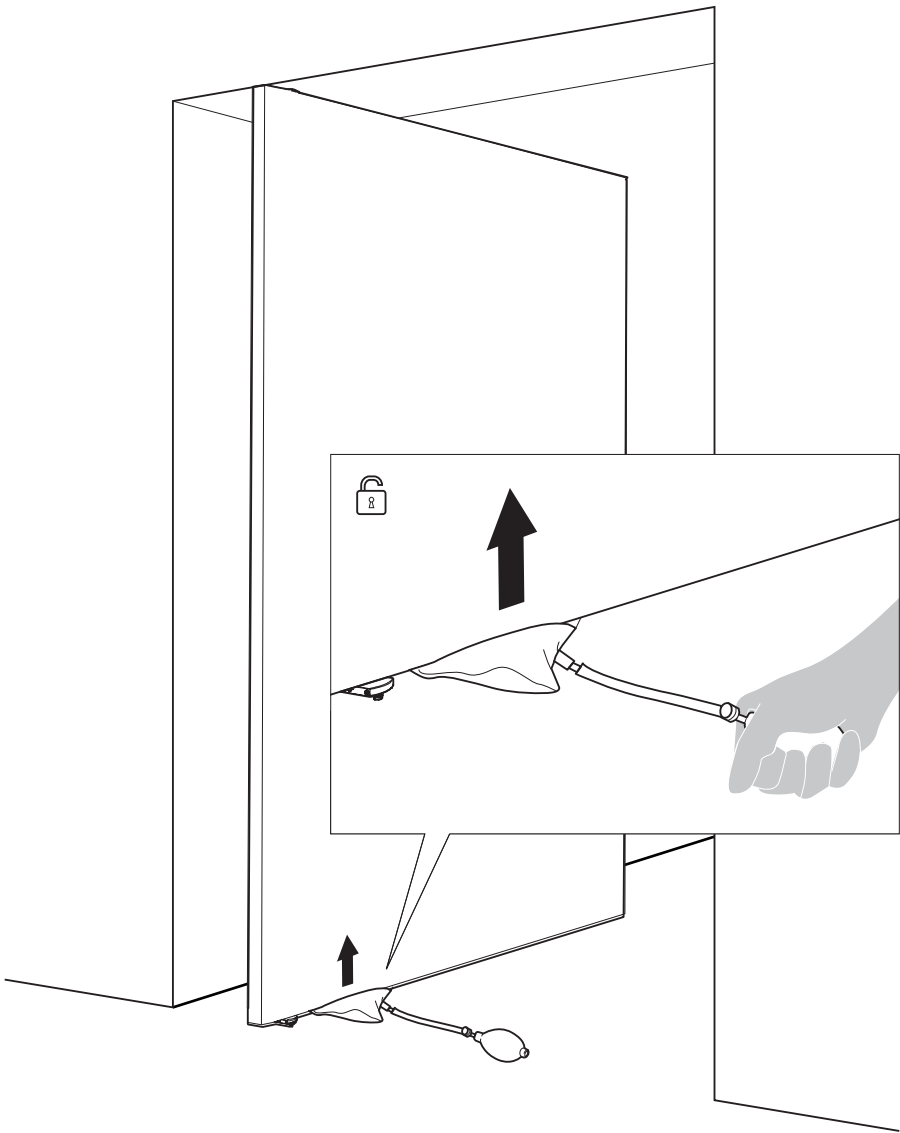

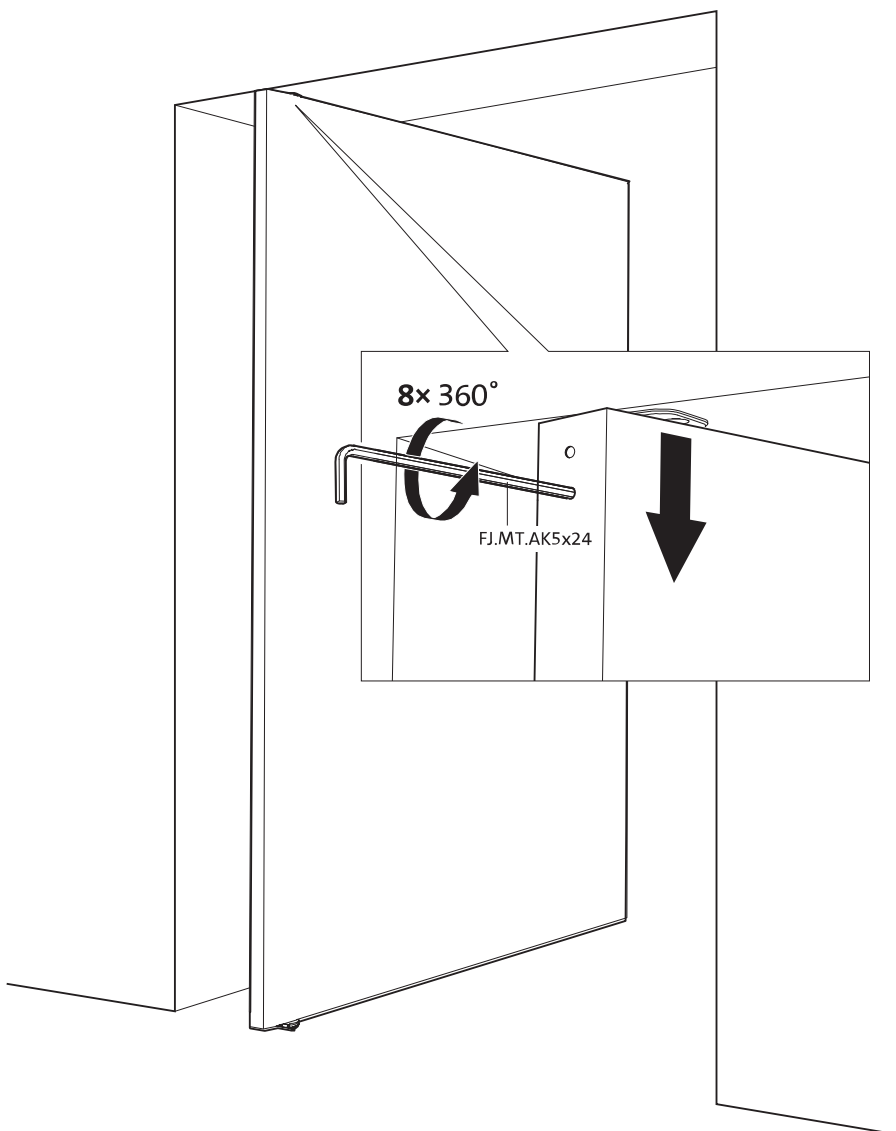

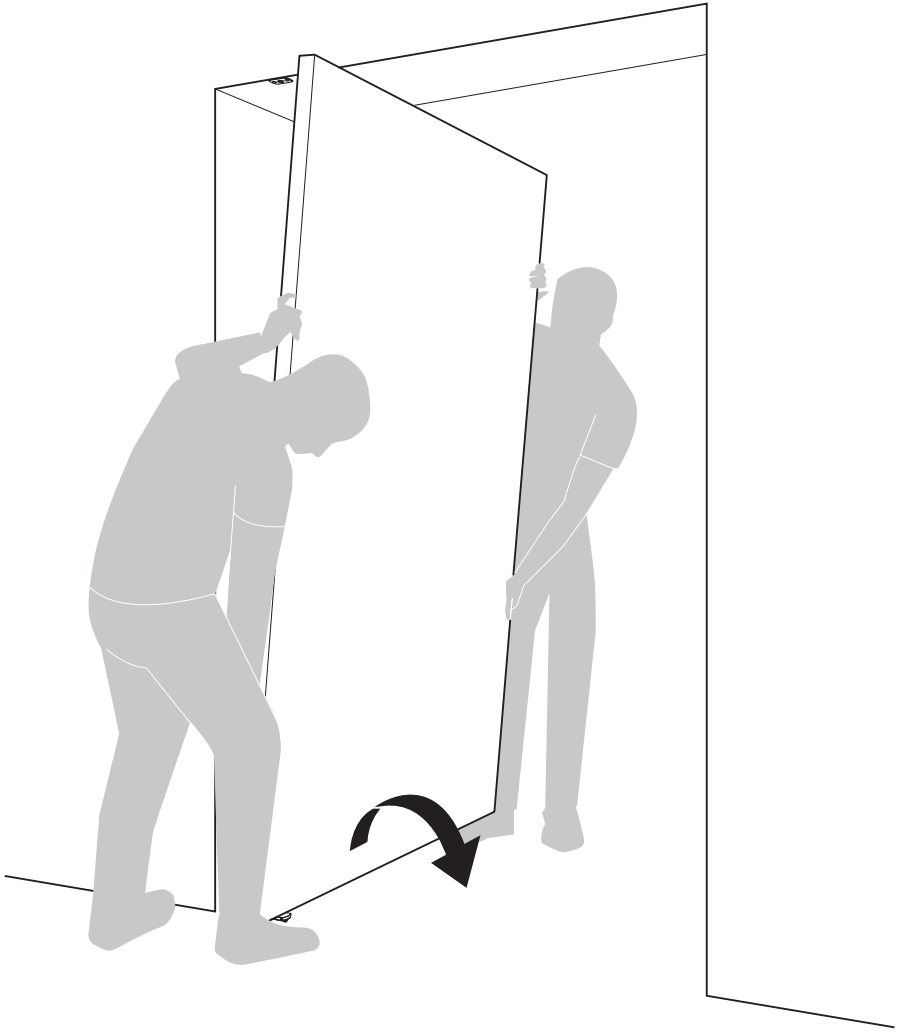



**FritsJurgens International**

A. Einsteinlaan 1  
The Netherlands  
9615 TE Kolham  
+31 598 343 410  
info@fritsjurgens.com

**FritsJurgens Dubai Branch**

DLC-OP-A2-4-0029  
Dubai South  
Dubai  
United Arab Emirates  
+971 4 820 8106  
+971 58 137 2611  
dubai@fritsjurgens.com  
fritsjurgens.com

Copyright © FritsJurgens®  
B.P.M.70.C.X.XX





