

# System M+

## Milling and mounting manual

FritsJurgens Set - 40 mm Class C - stainless steel

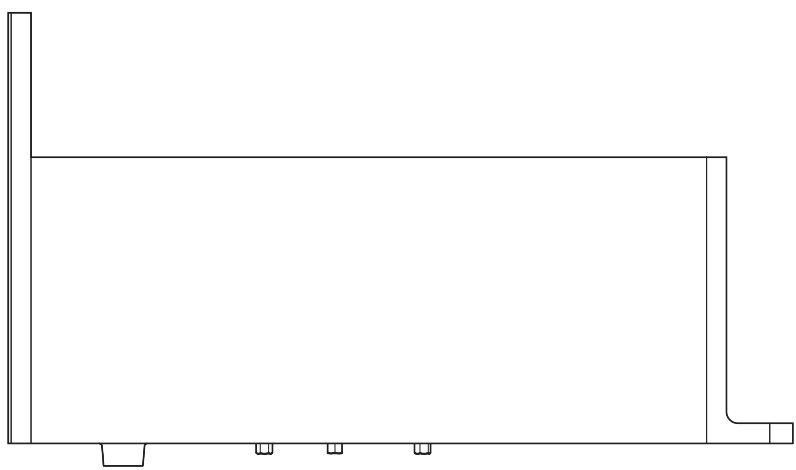



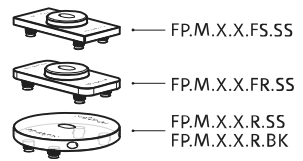
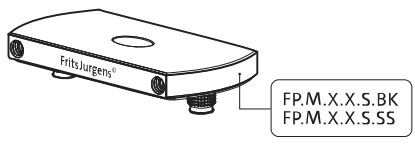
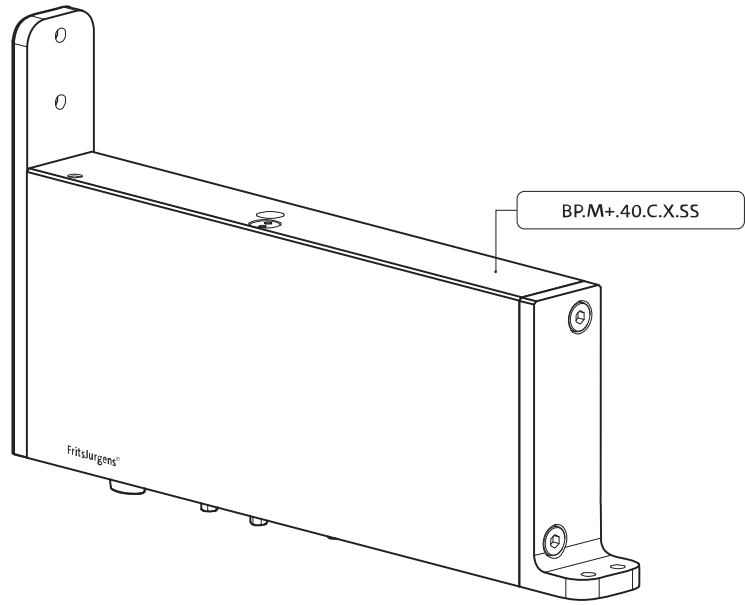
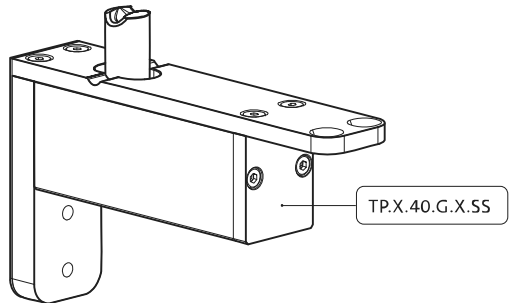
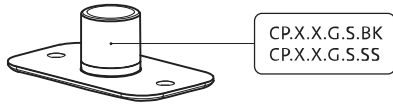



# Milling instructions

# BP.M+.40.C.X.SS

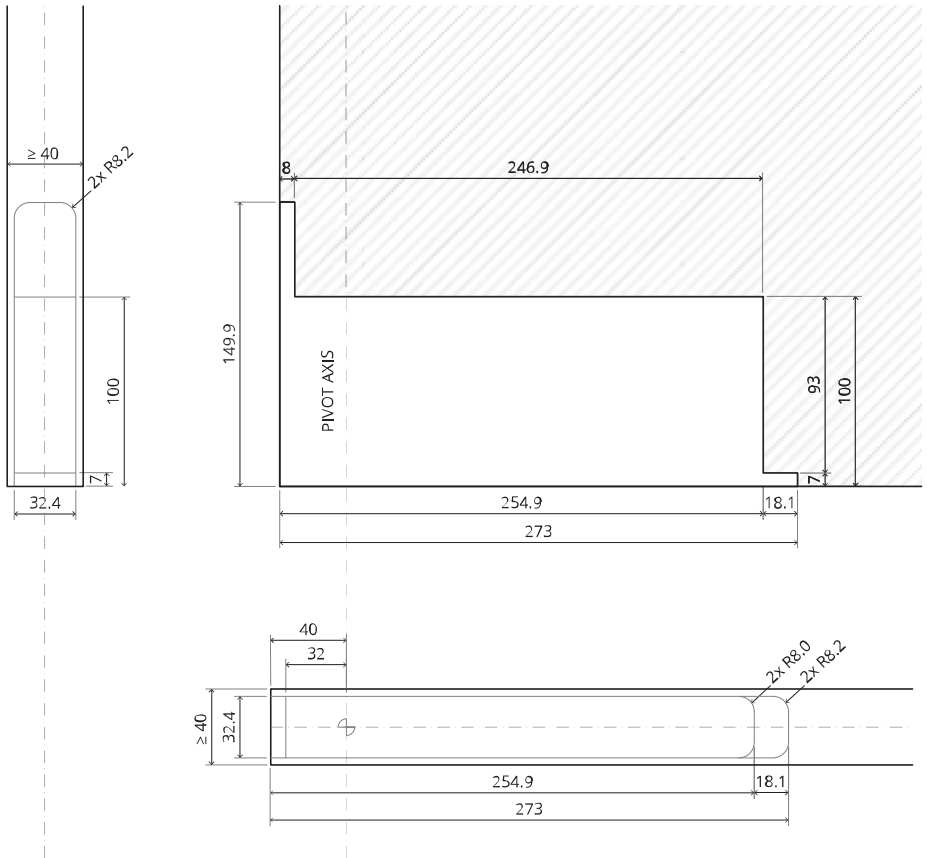

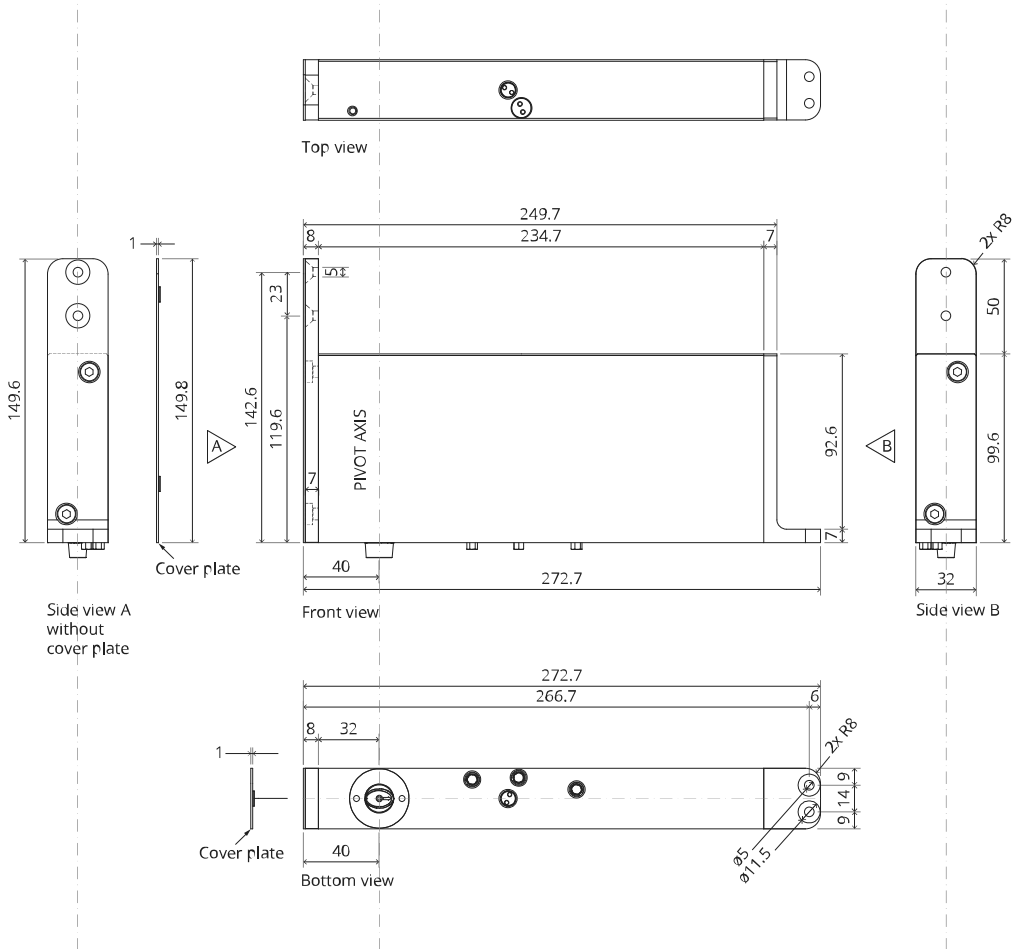

# TP.X.40.G.X.SS

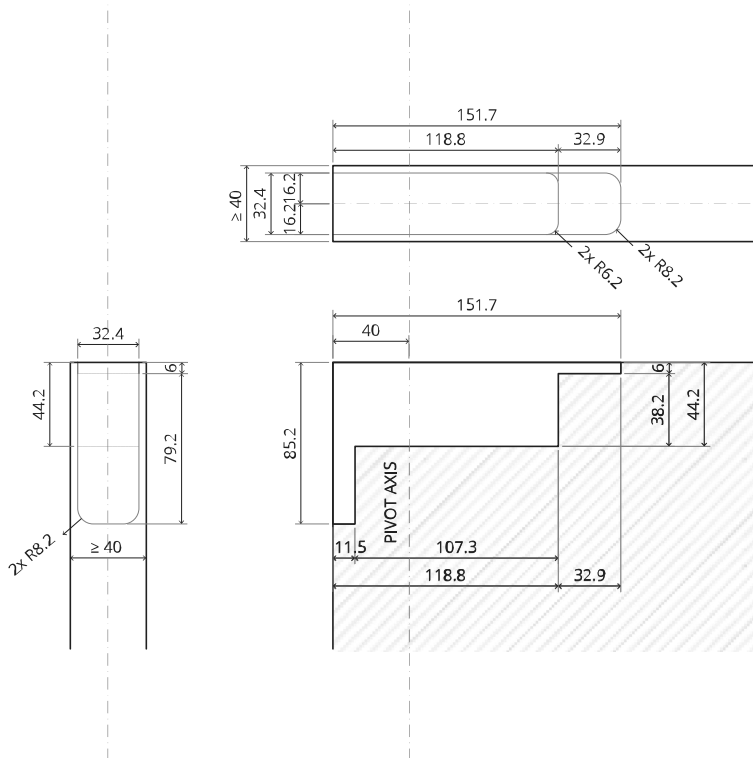



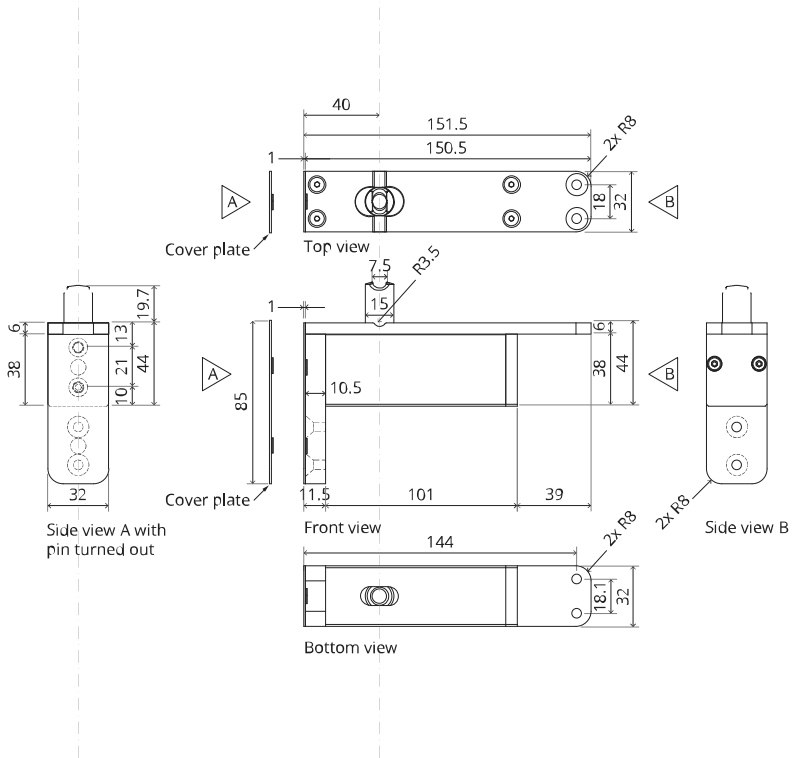

# FP.M.X.X.FS.SS

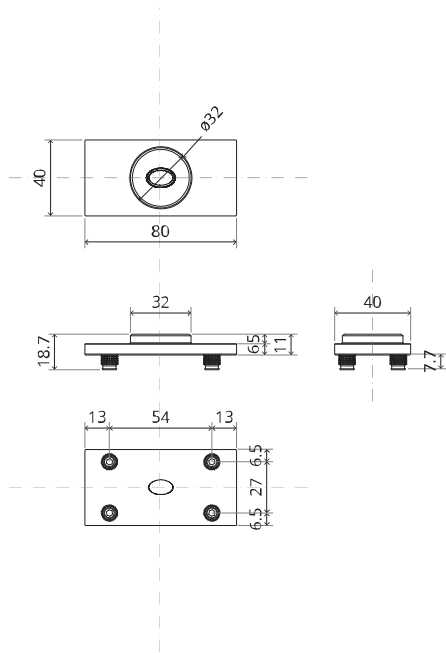
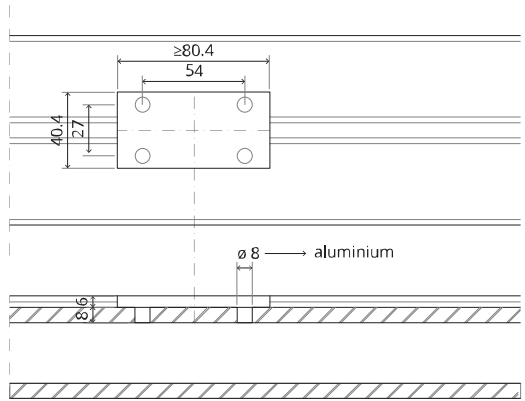

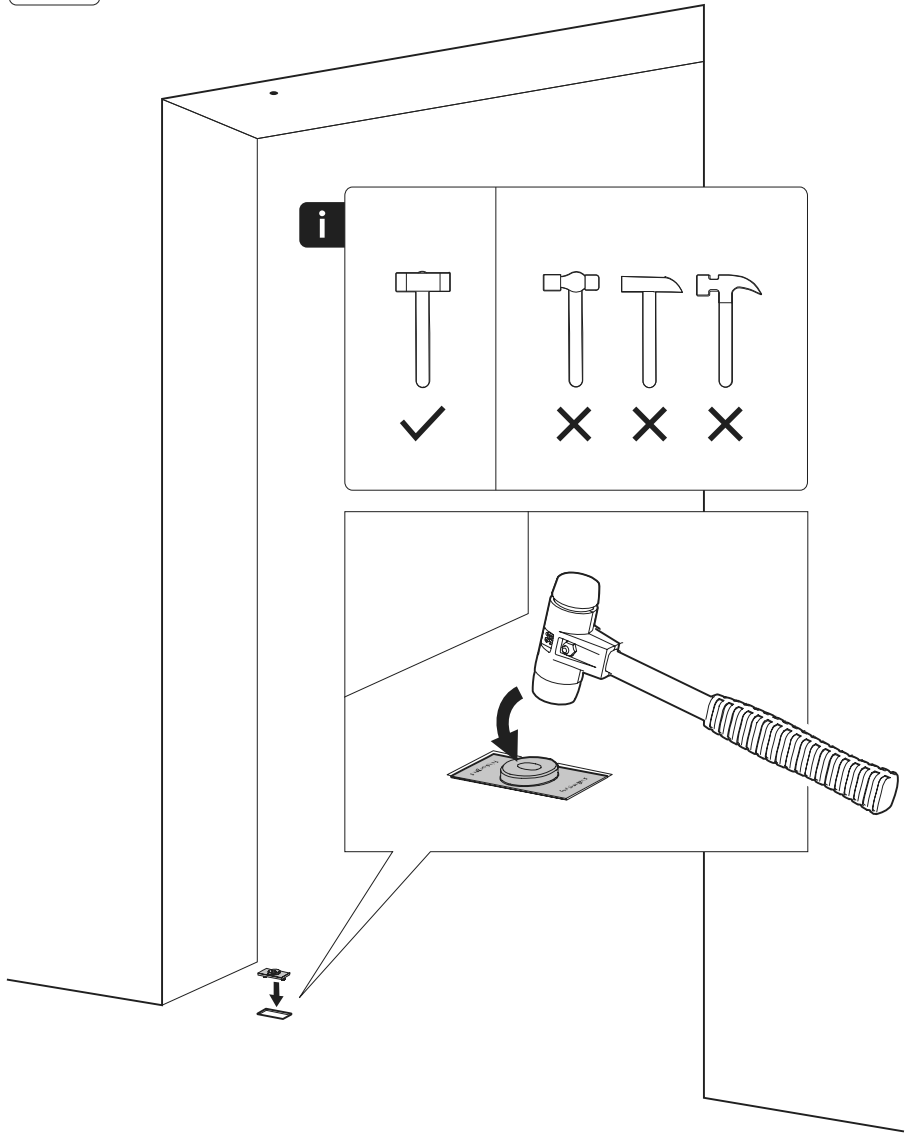

# FP.M.X.X.FR.SS

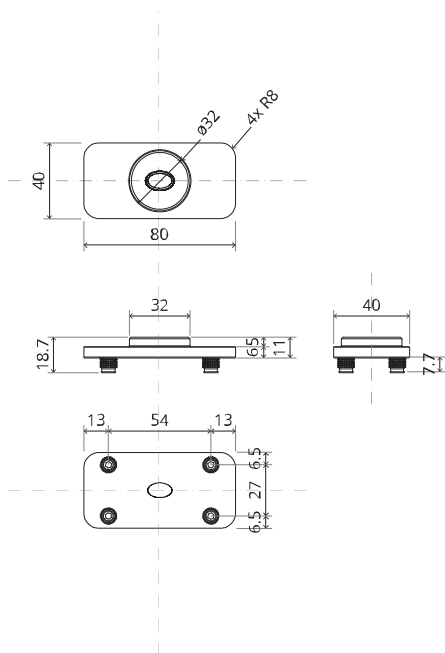
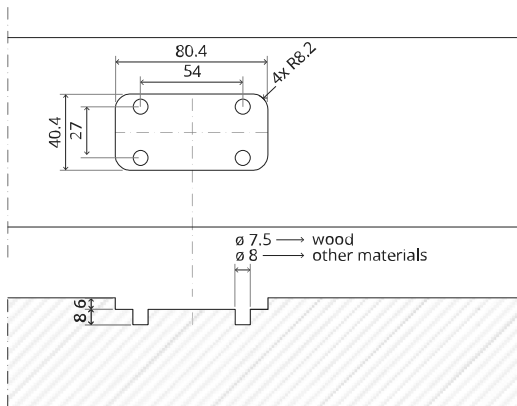

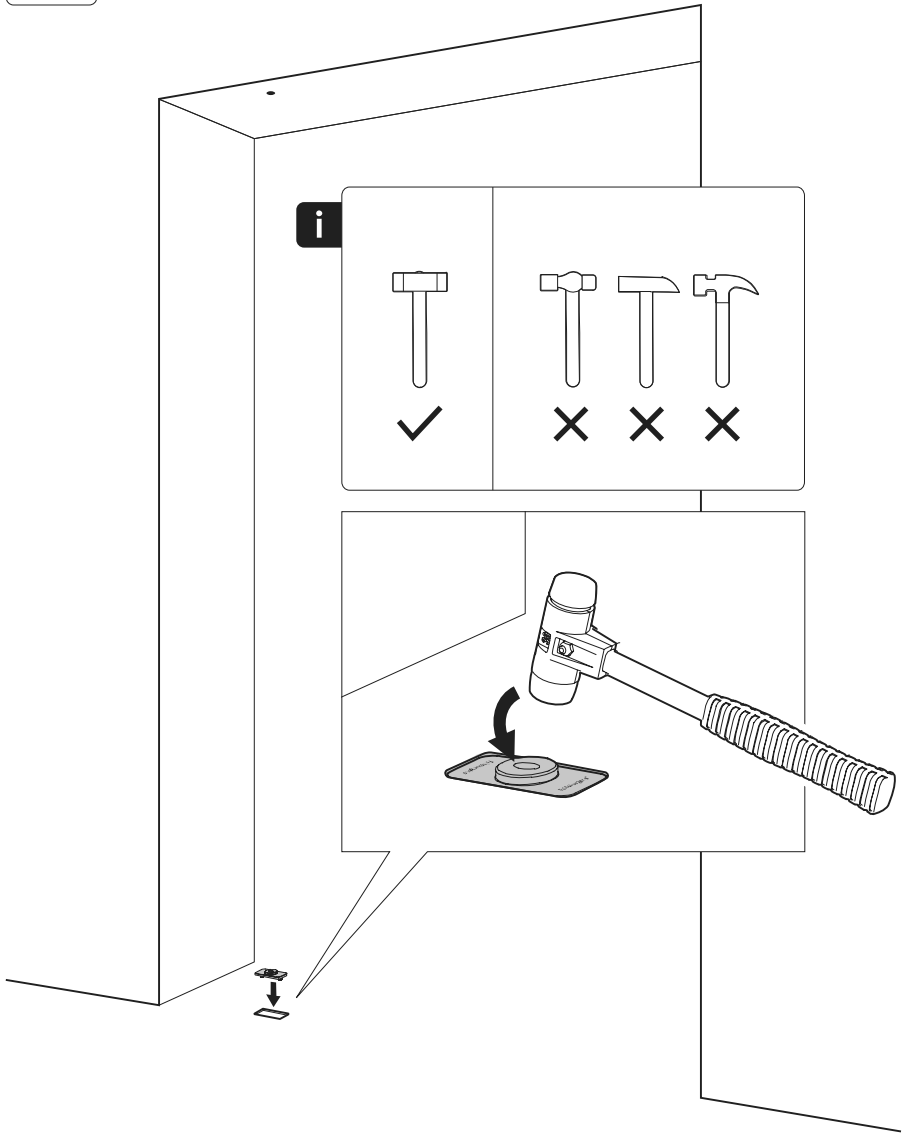



# Mounting instructions

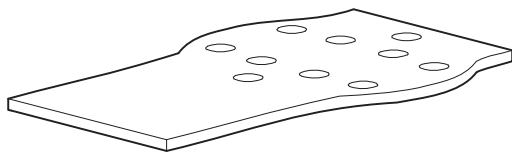

FJ.MT.DT.M



FJ.MT.Z5



10x FJ.Tx.4.0X50.PKDD



FJ.Bit.Tx20

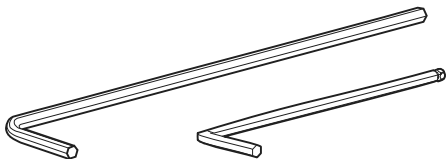

FJ.MT.AK3



FJ.MT.AK5x24

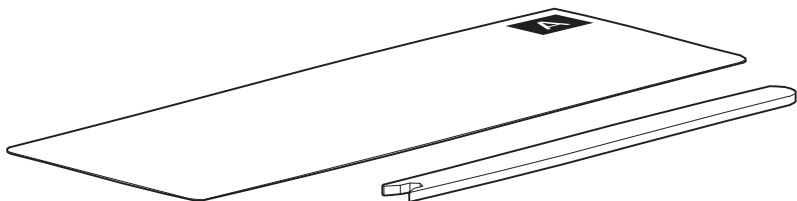

FJ.MT.AC.M+

FJ.MT.AS.M

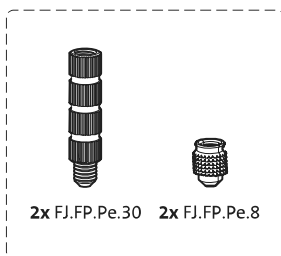

2x FJ.FP.Pe.30 2x FJ.FP.Pe.8

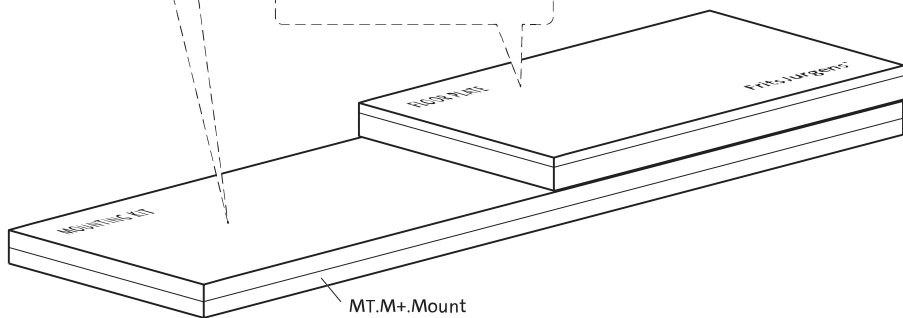



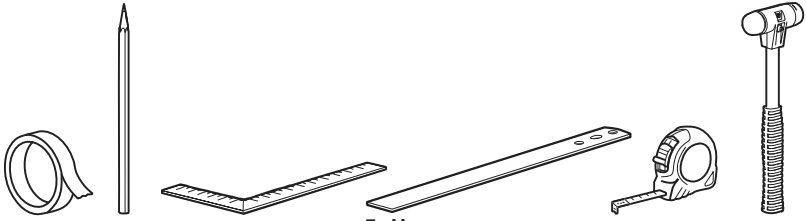

To.M

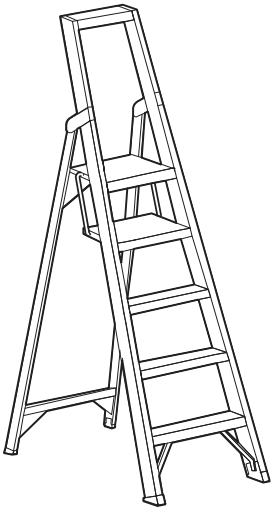
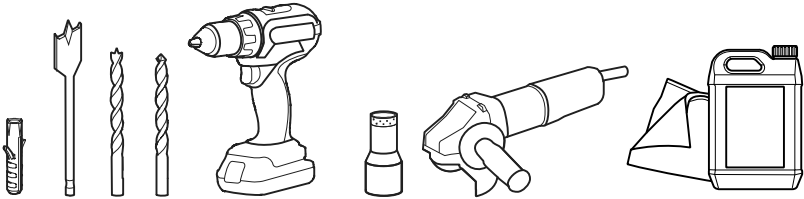

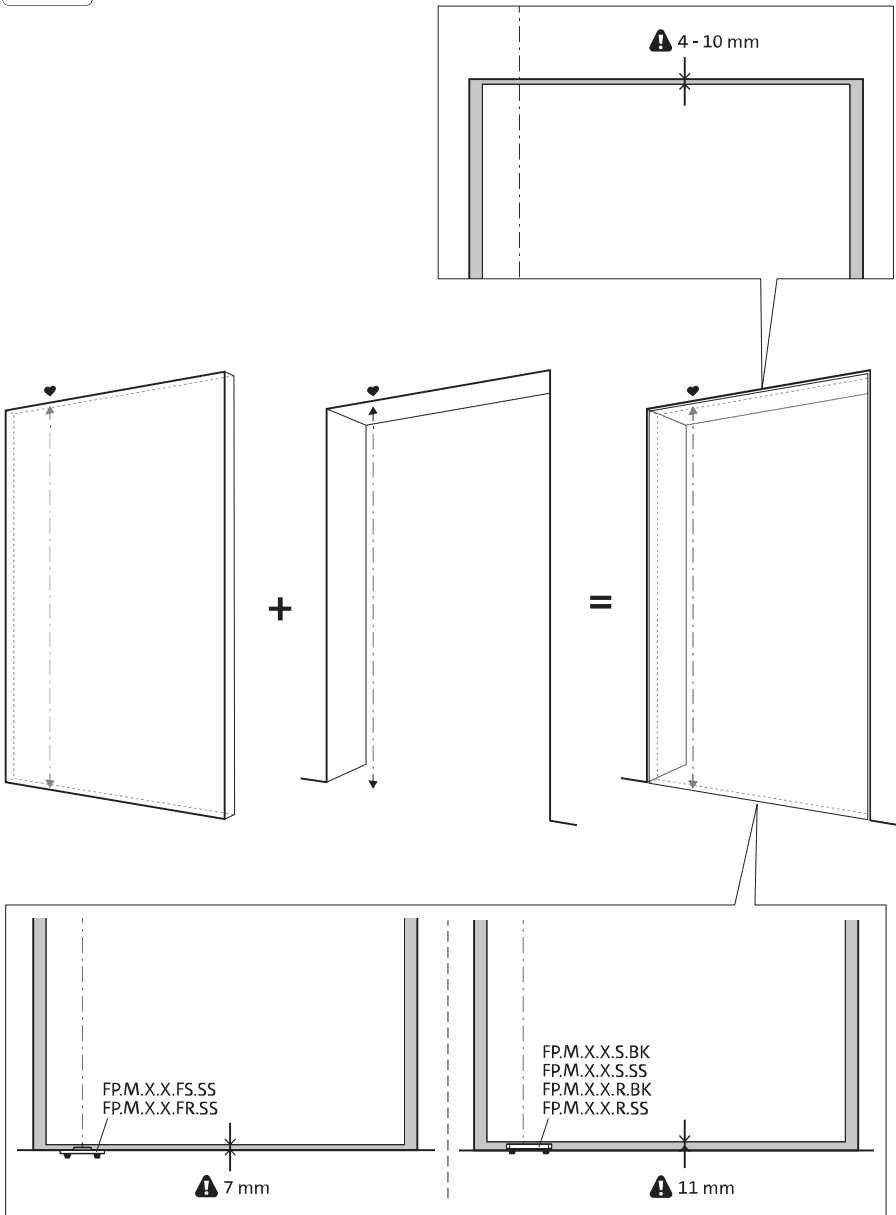



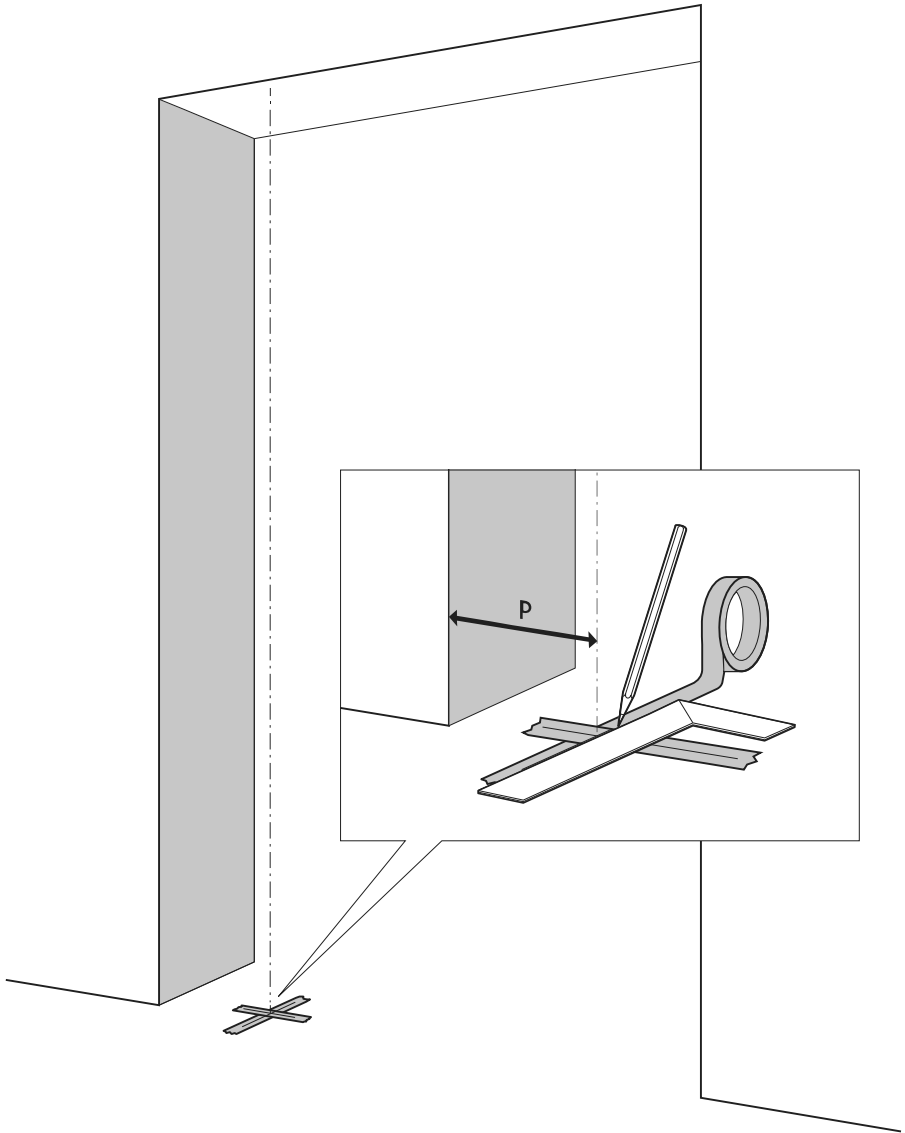

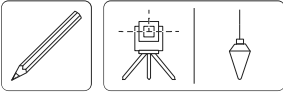

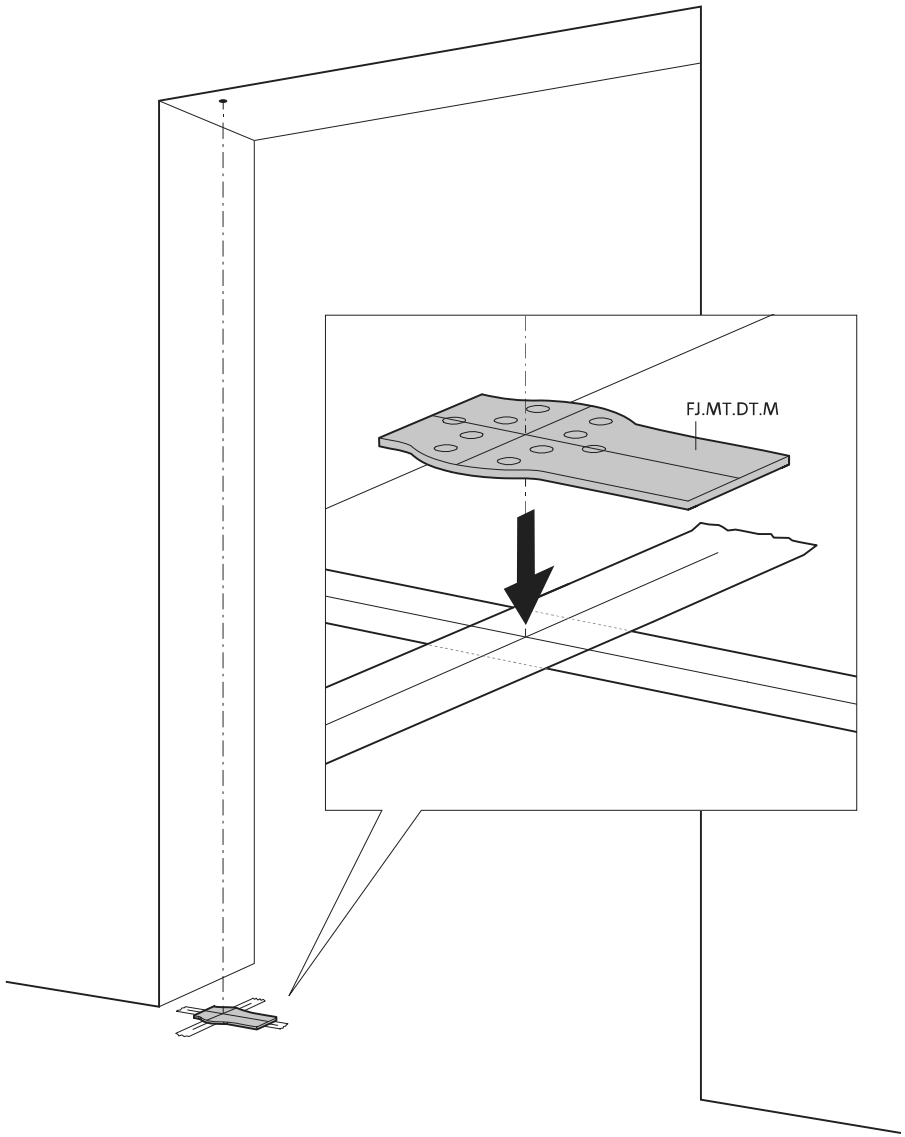

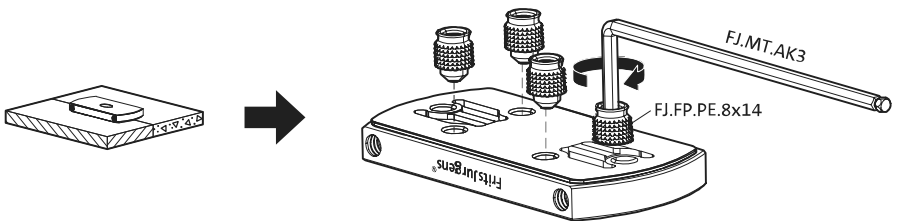
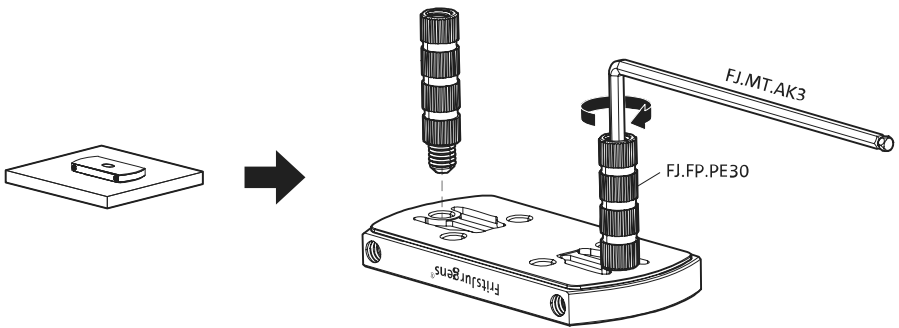
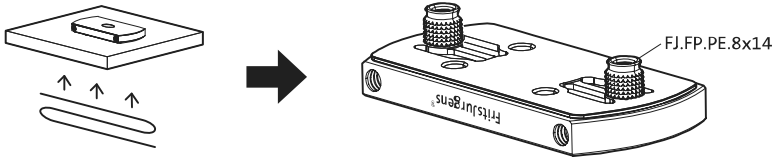



ø8 mm (5/16")

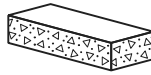
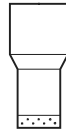

ø8 mm (5/16")

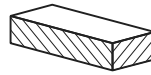

ø7.5 mm (19/64")

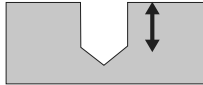

8 mm (5/16")

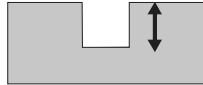

8 mm (5/16")

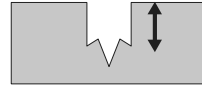

8 mm (5/16")

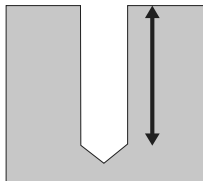
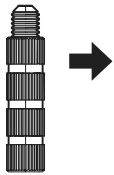

30 mm (13/16")

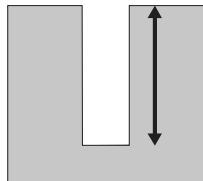

30 mm (13/16")

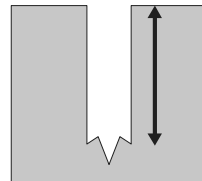

30 mm (13/16")



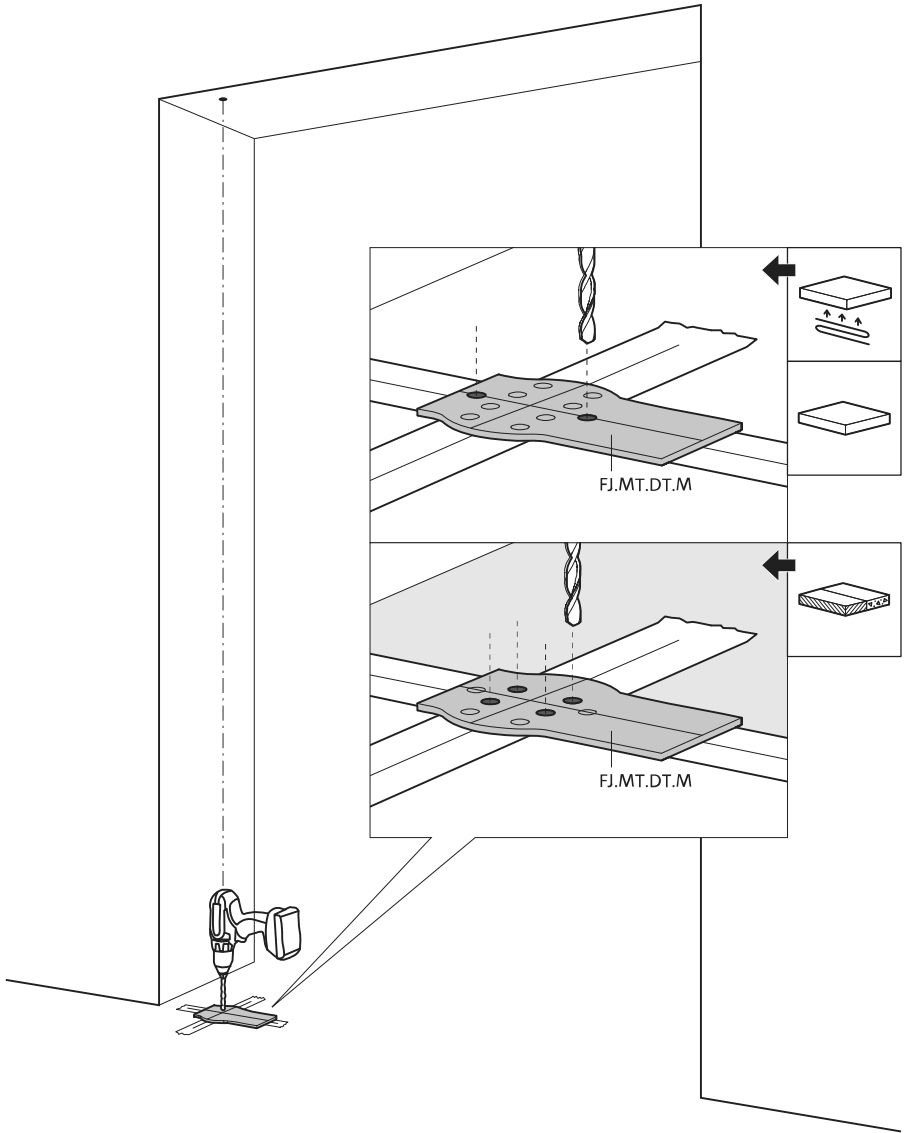

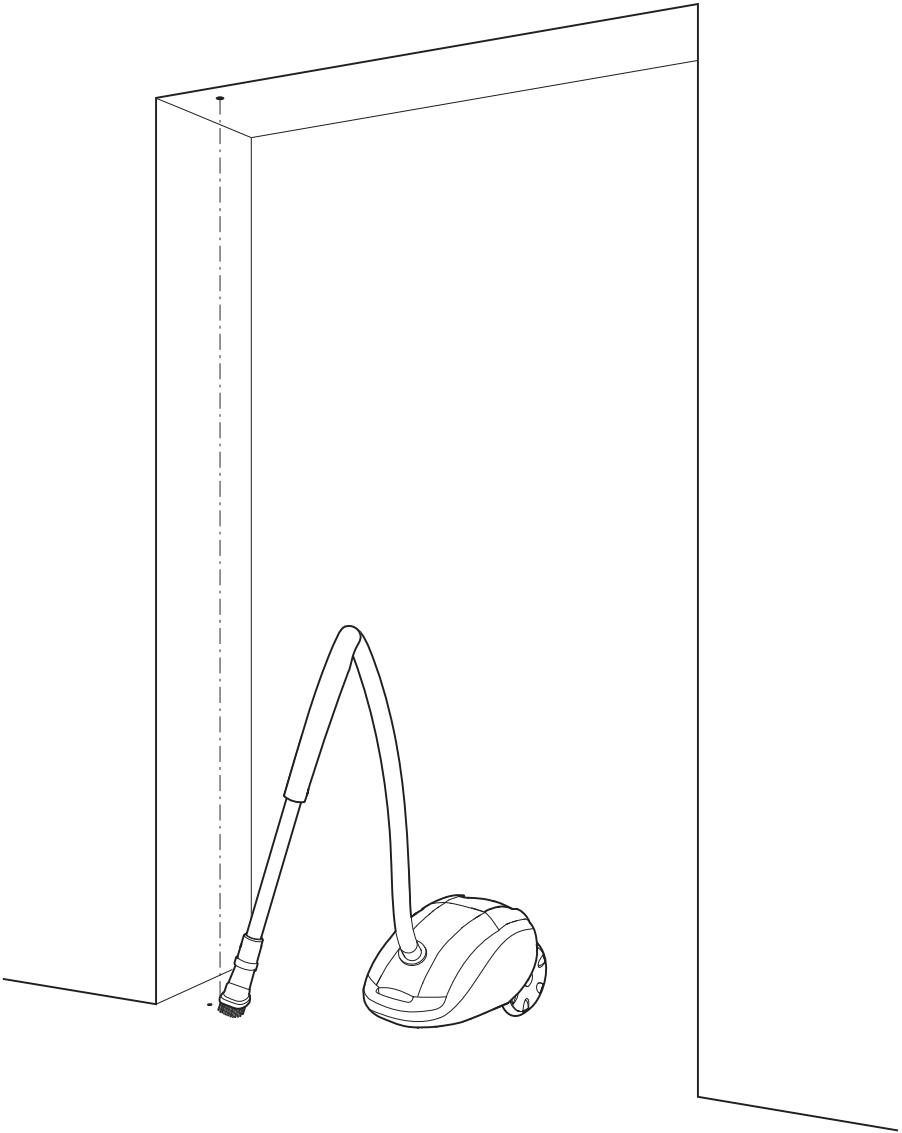



1

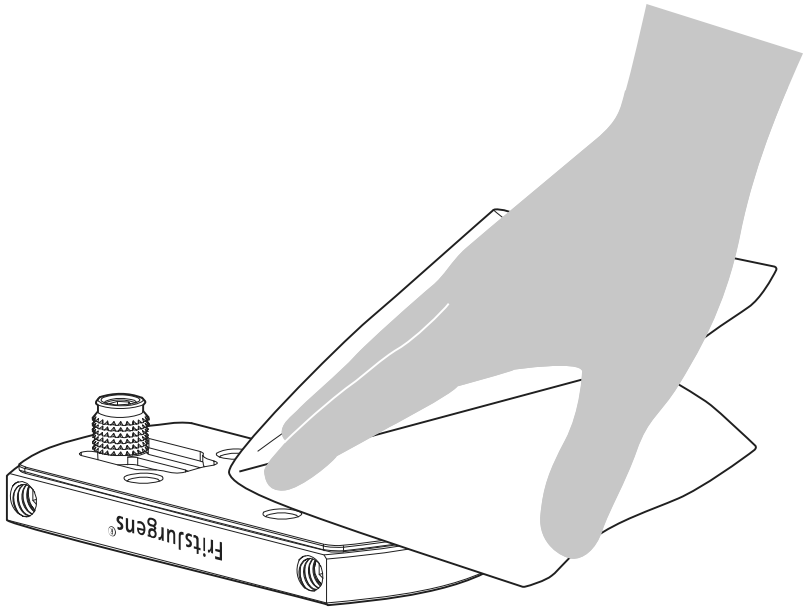

2

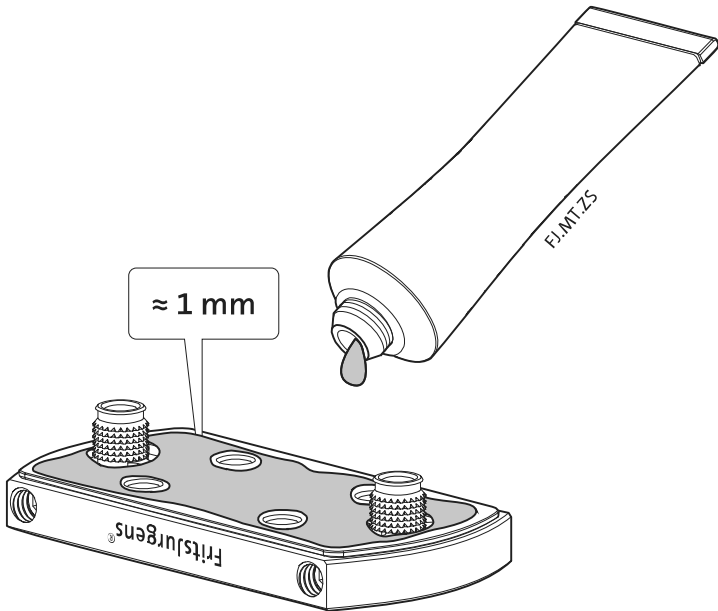

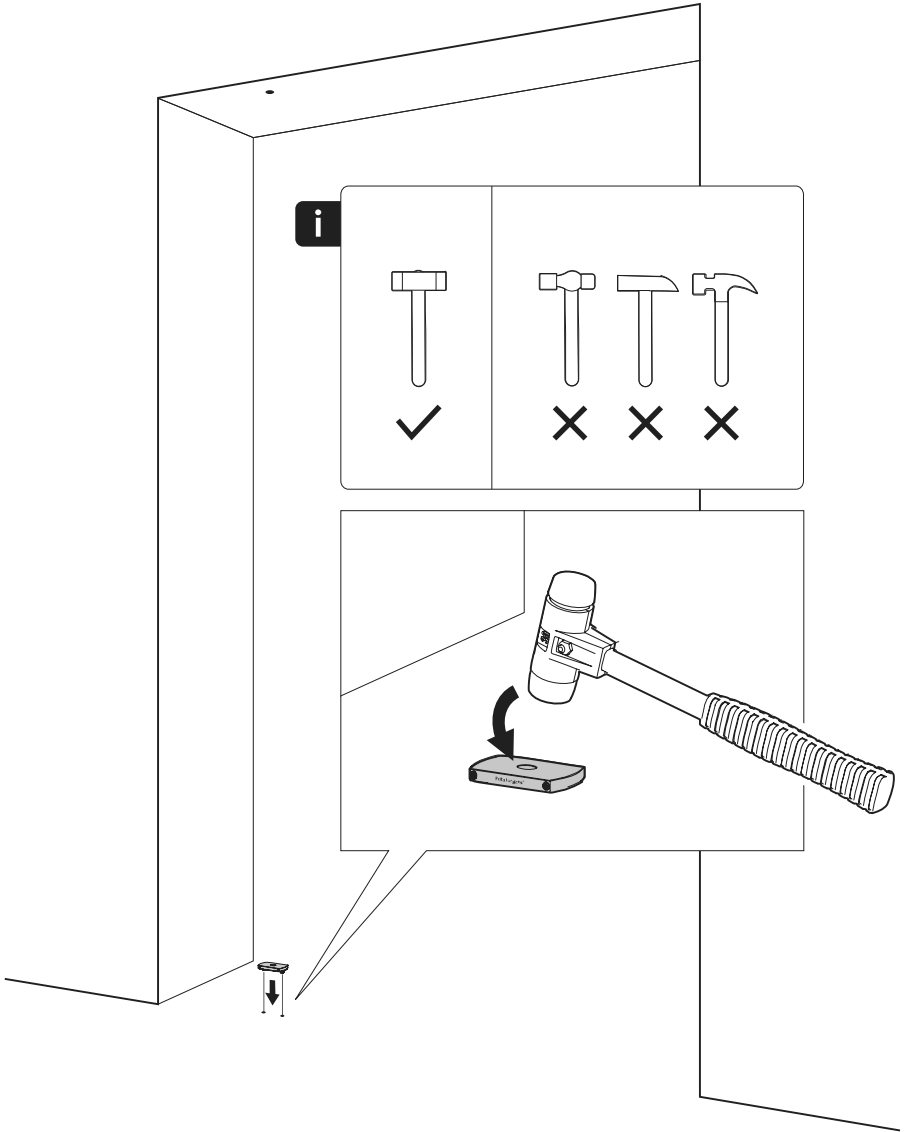

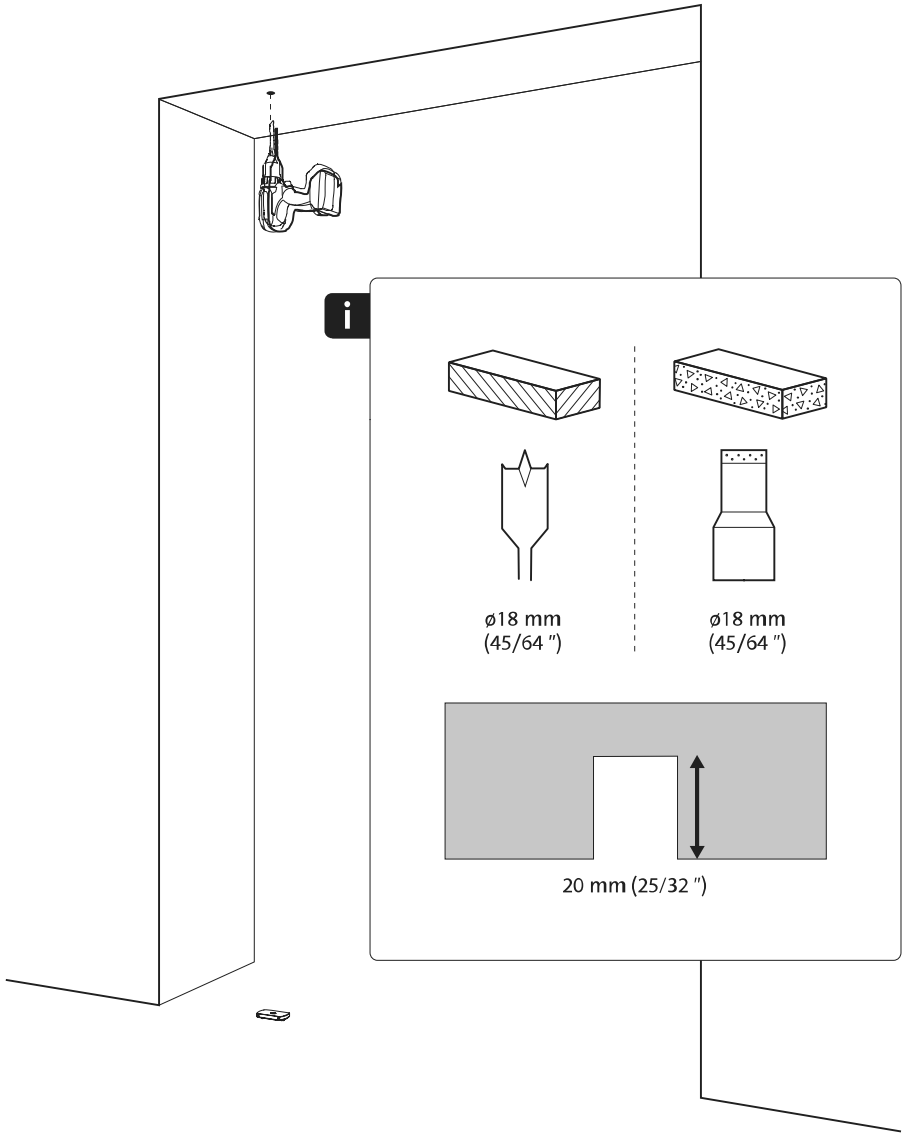



1

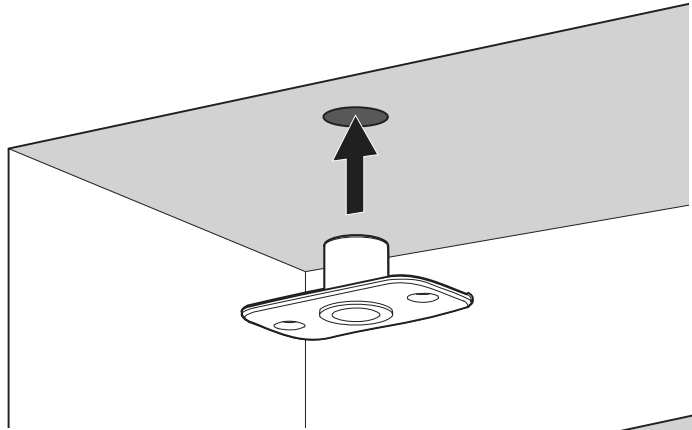

2

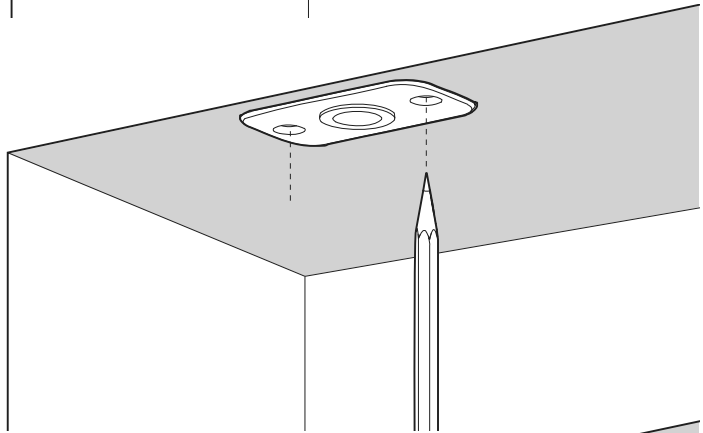

3

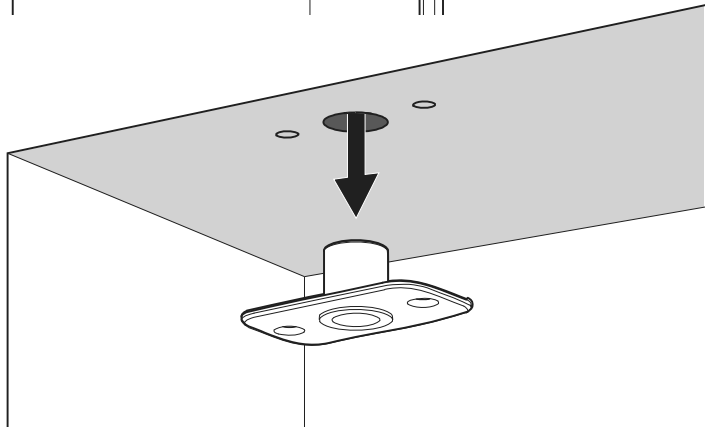



1

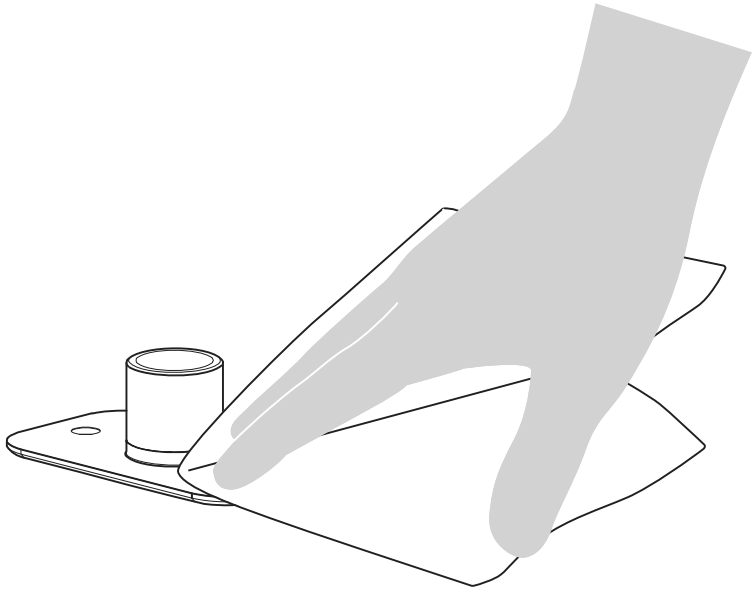

2

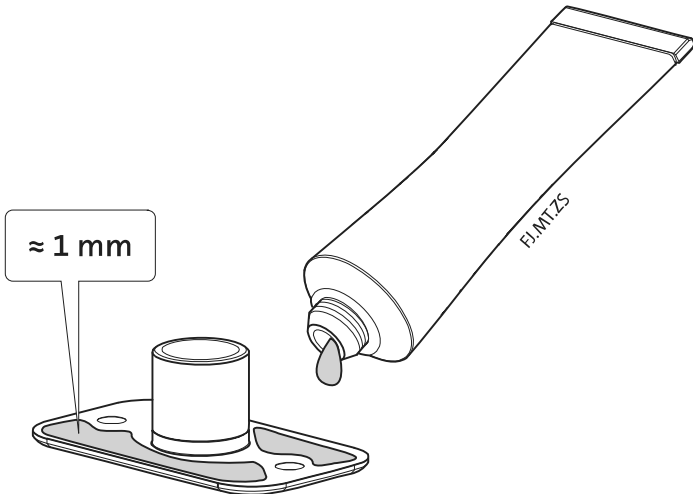

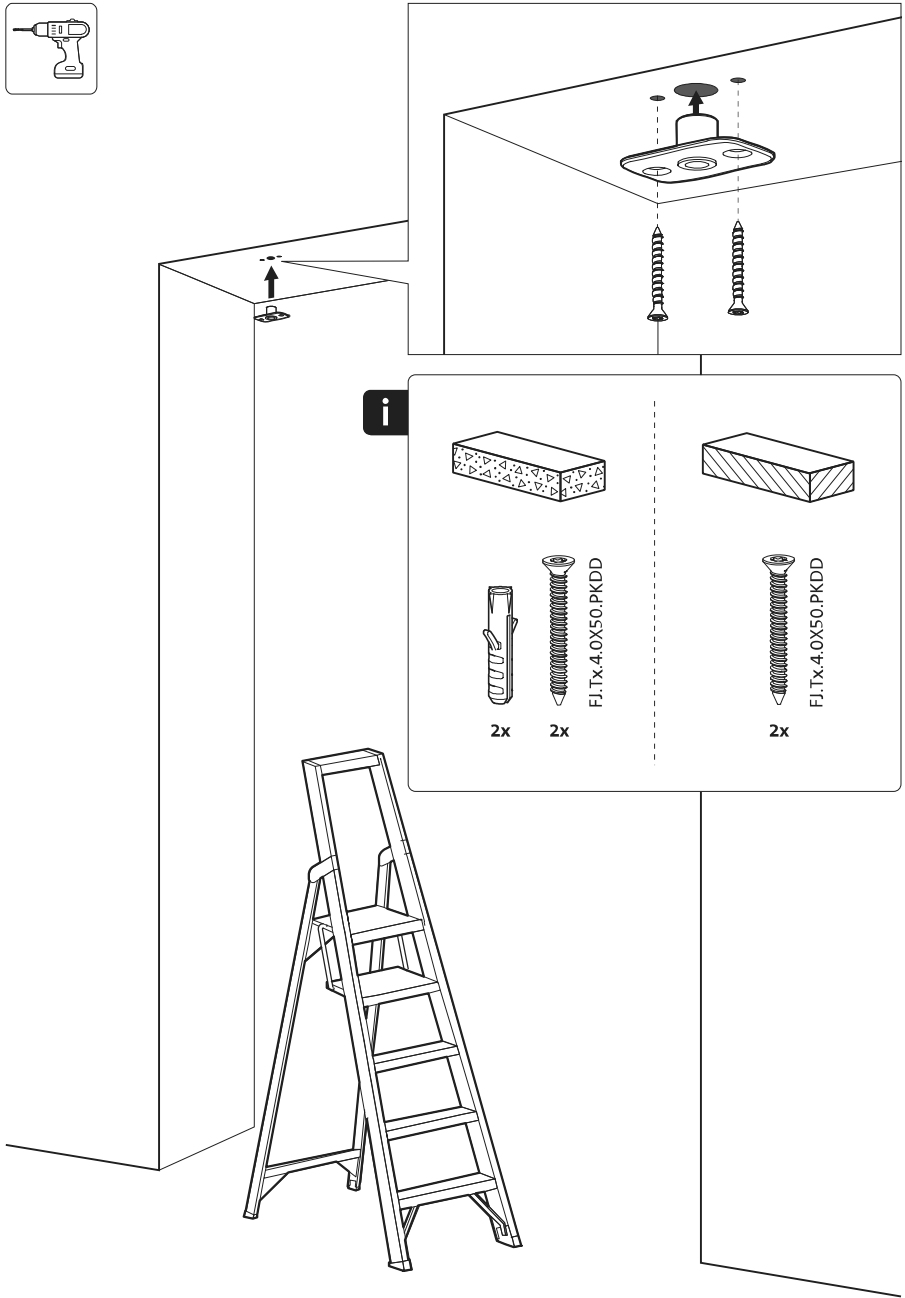



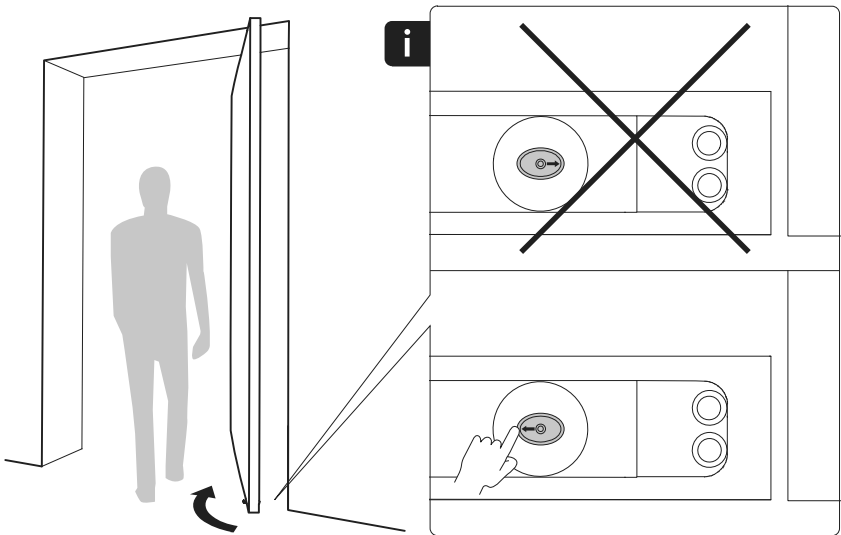
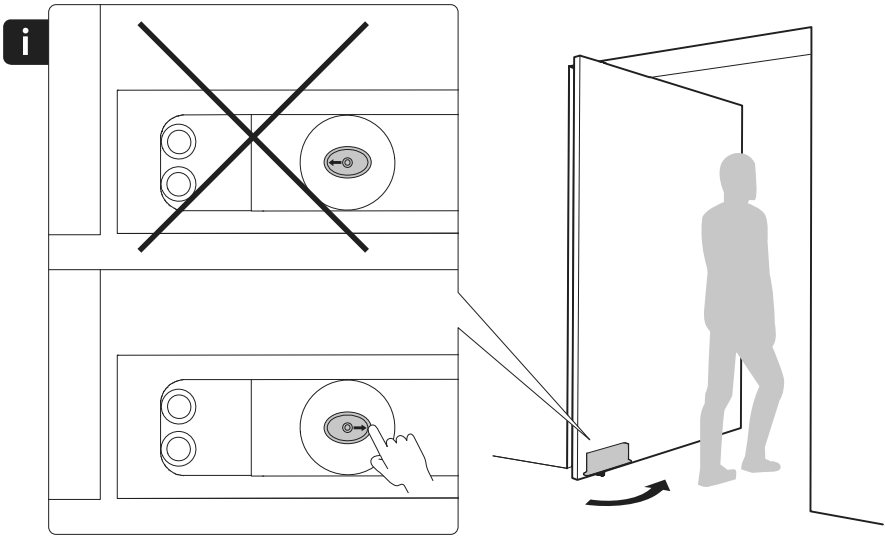

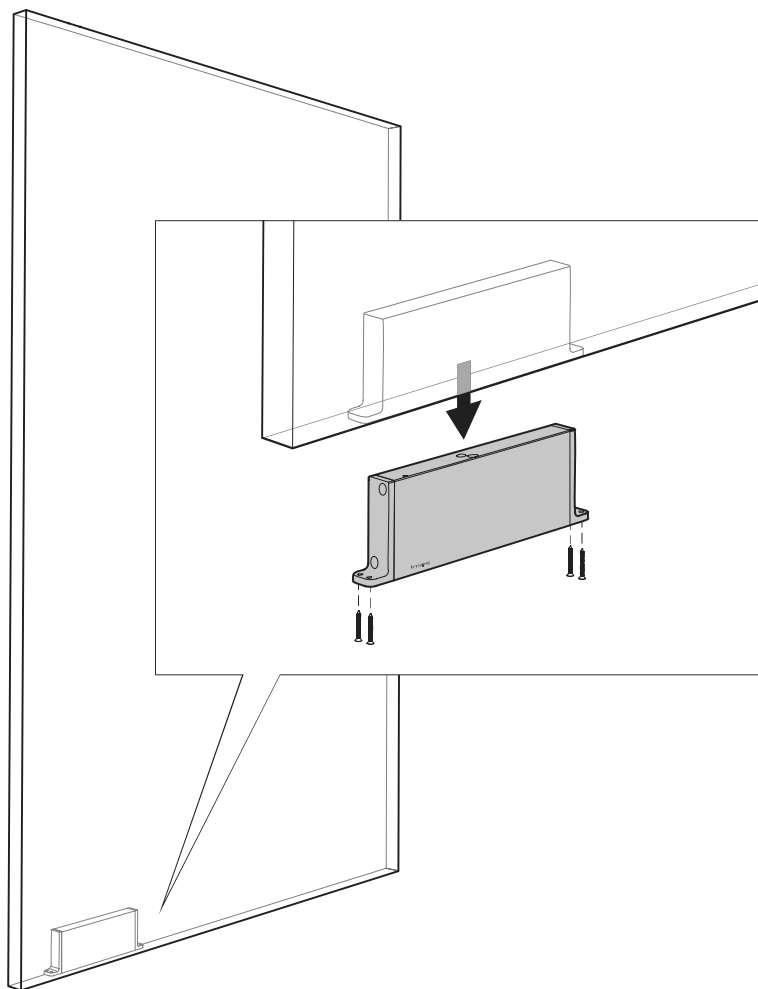

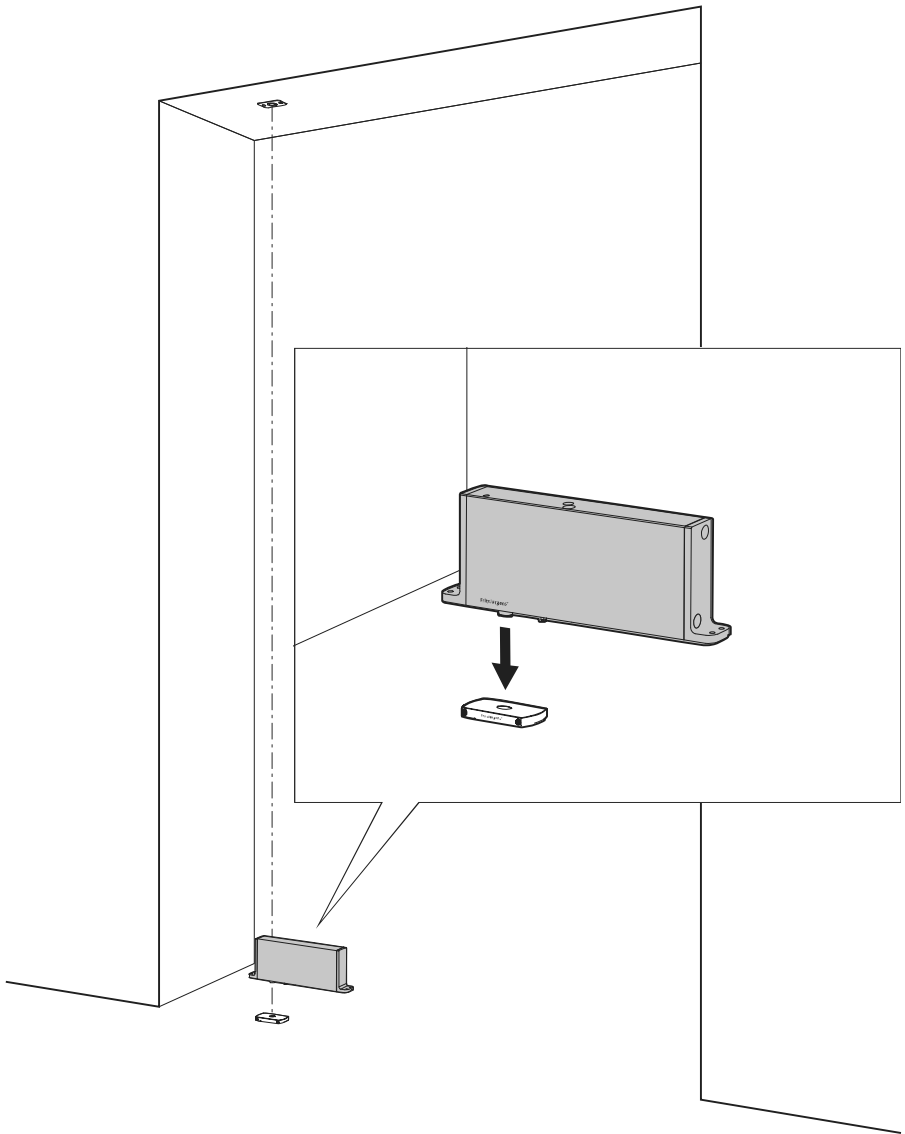

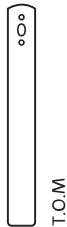
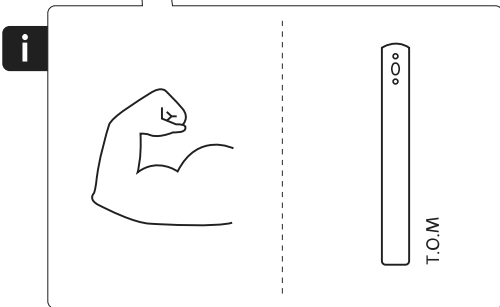
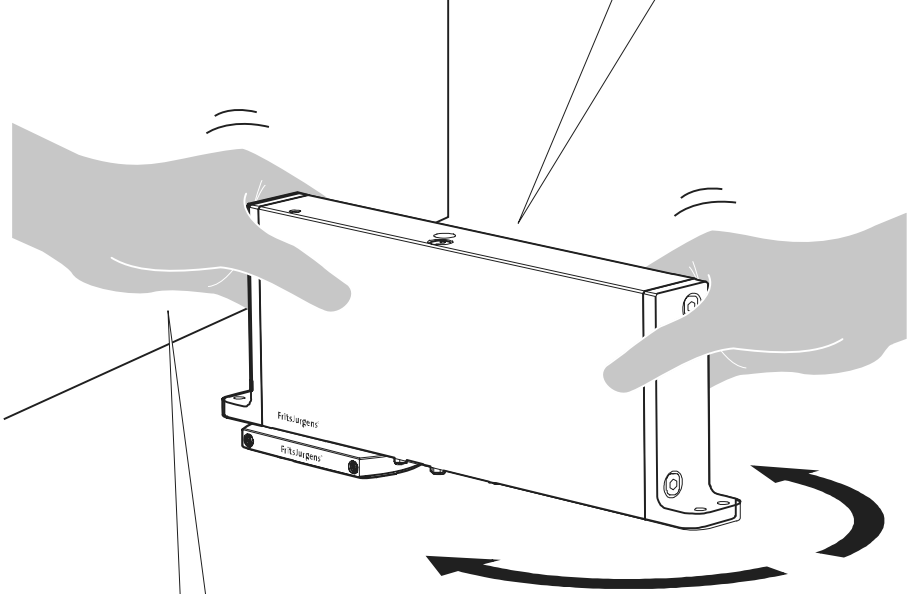
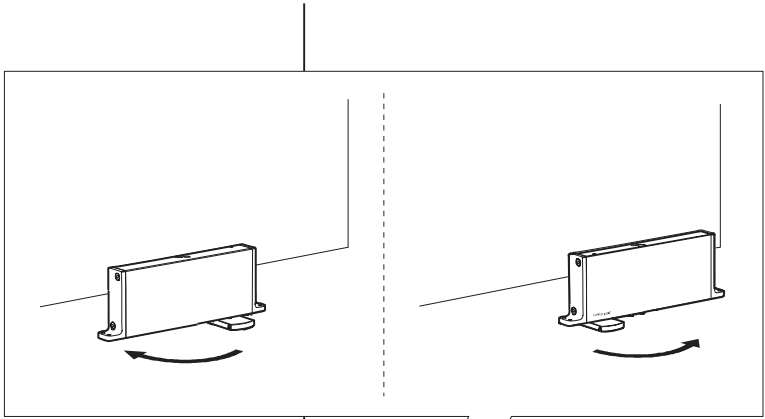

T.O.M

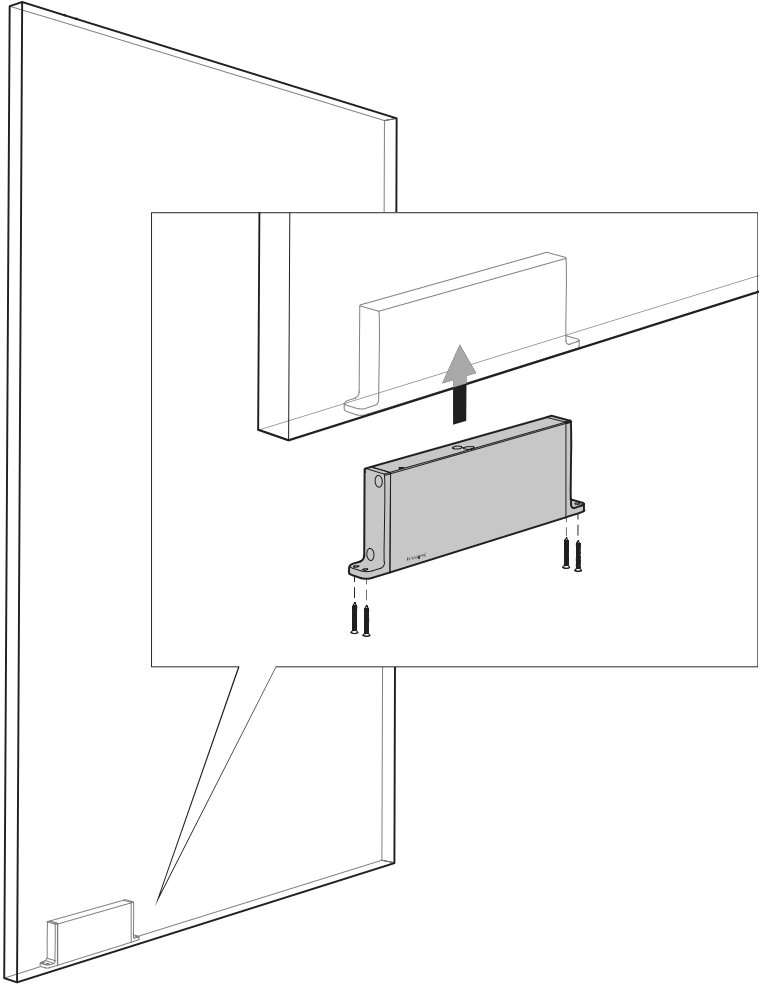

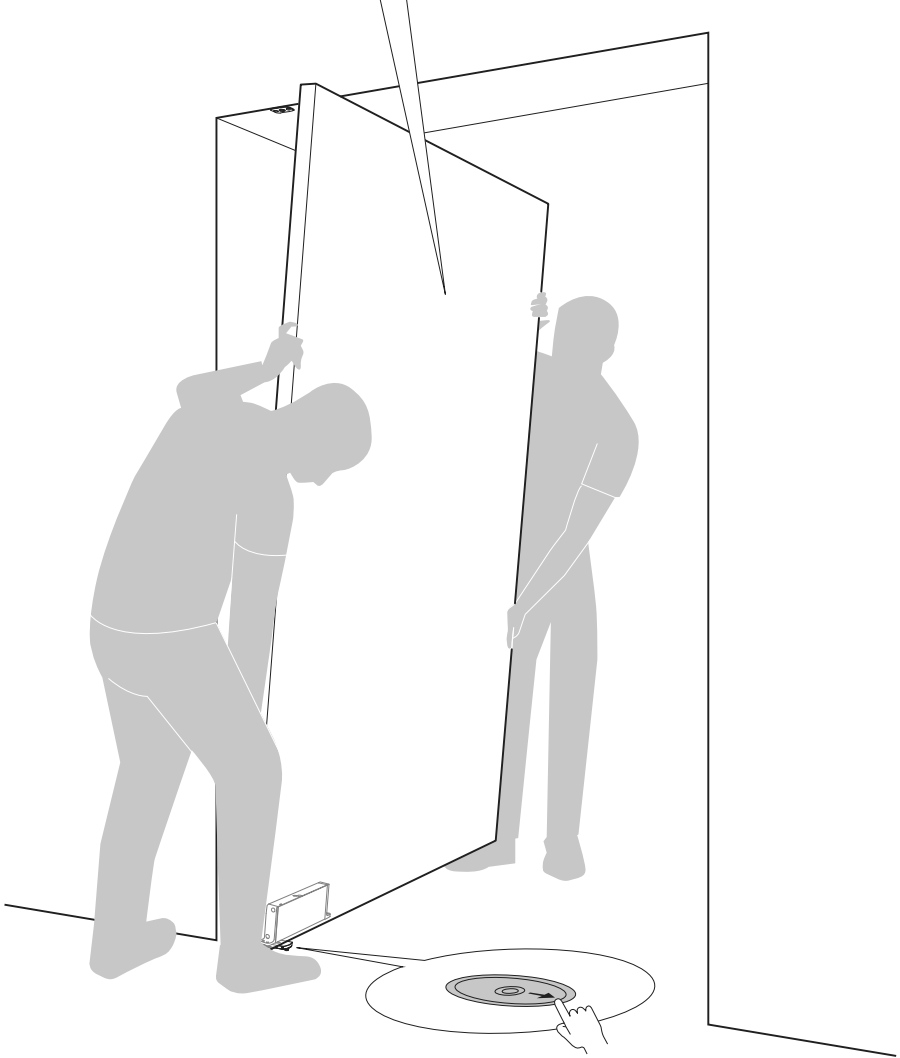
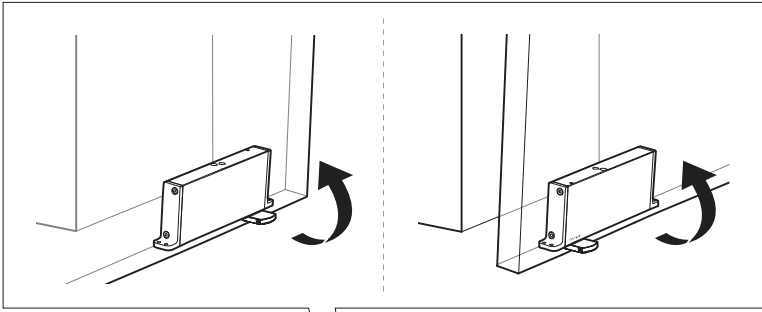

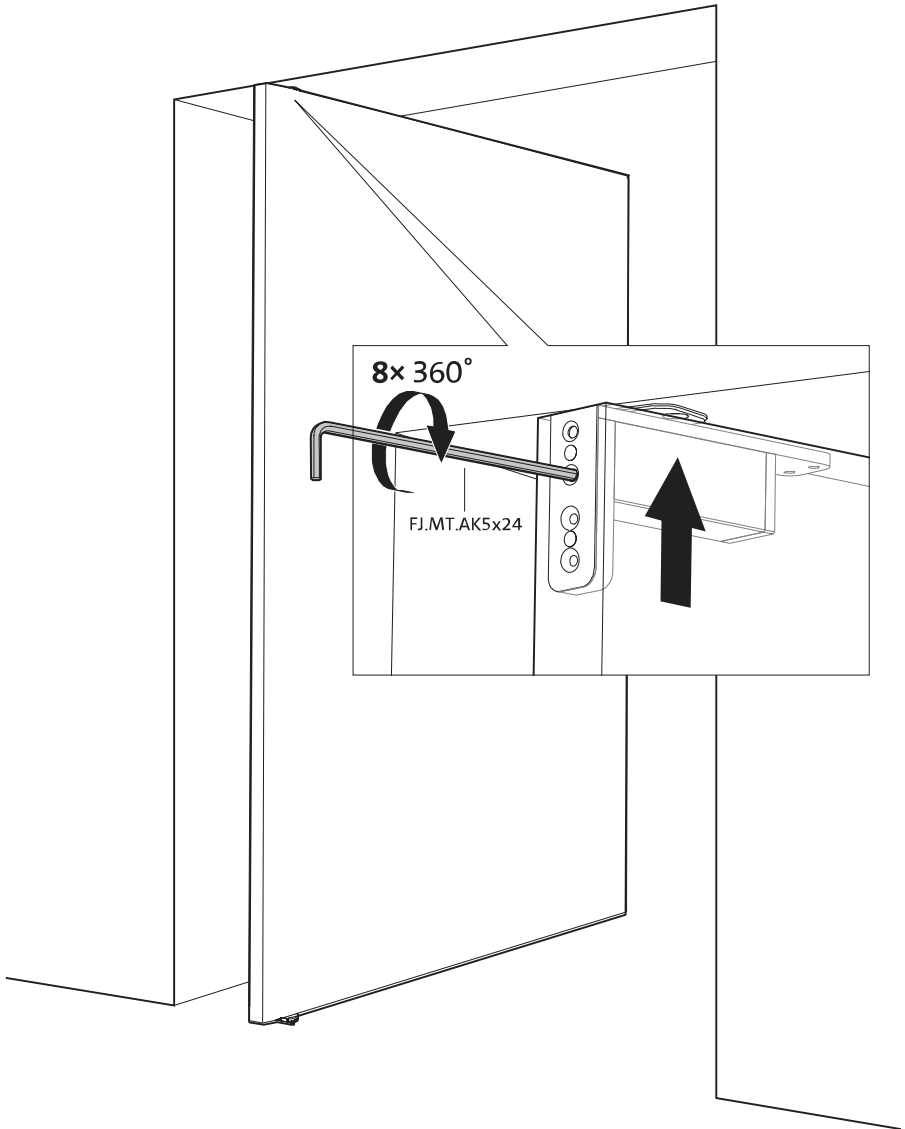
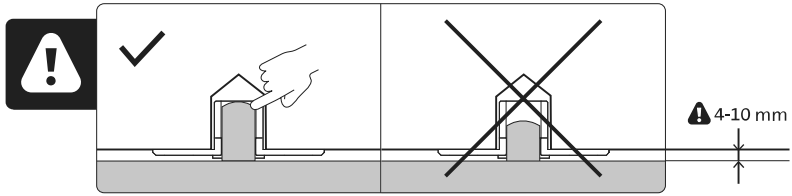

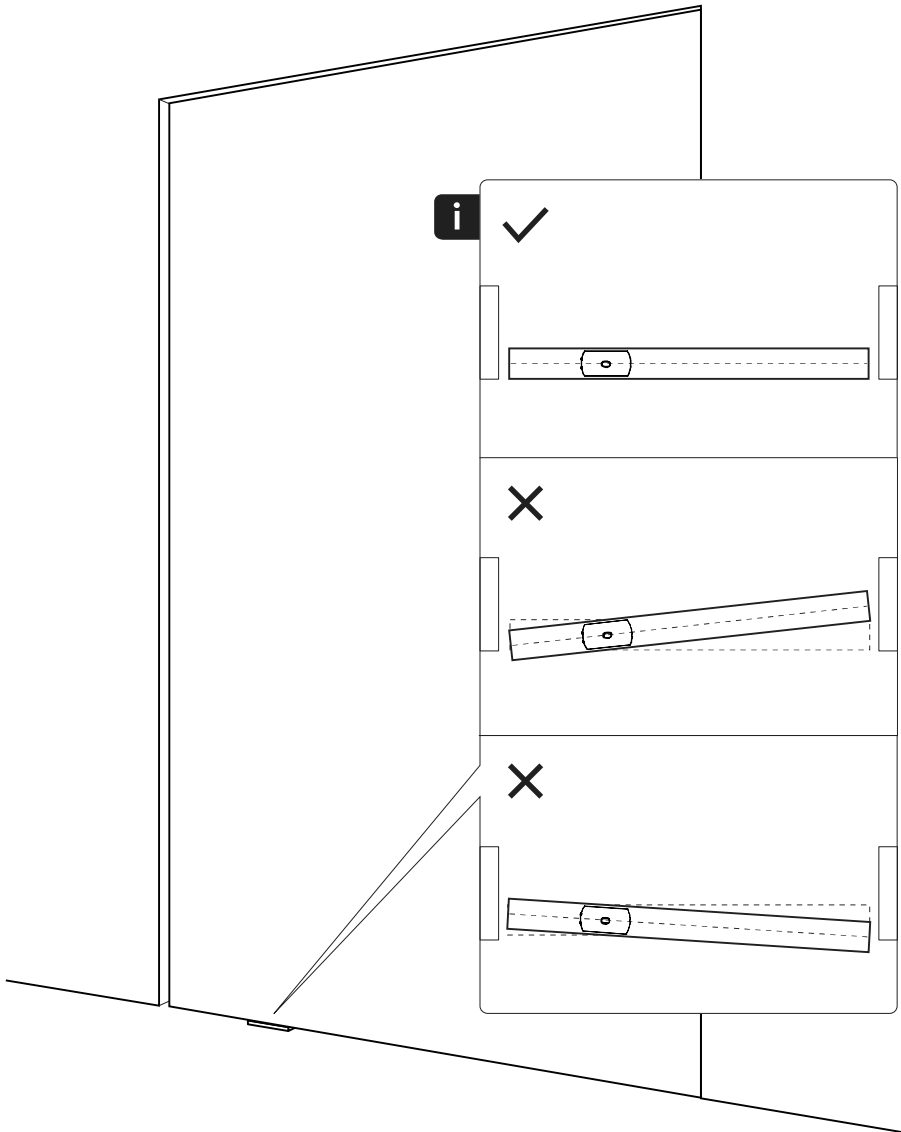



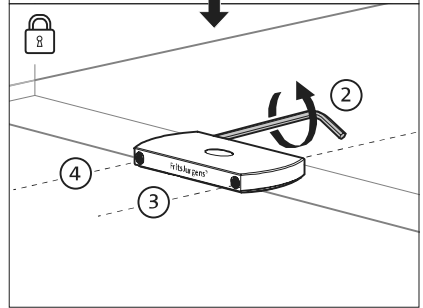
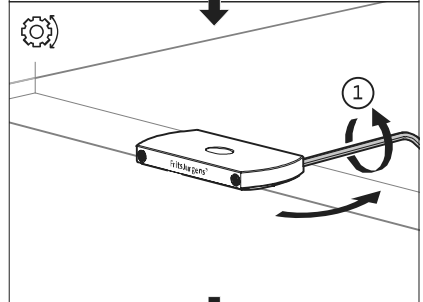
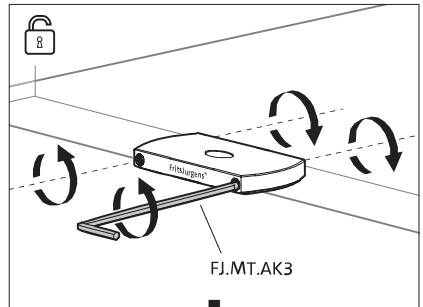
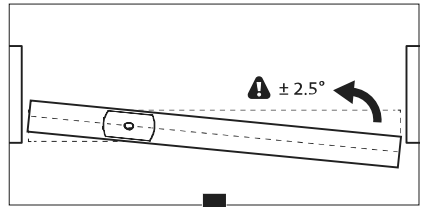
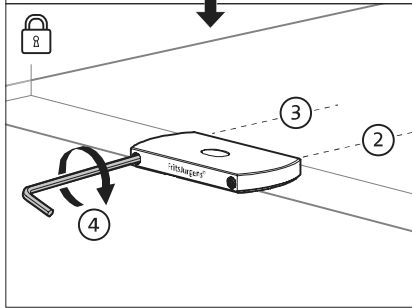
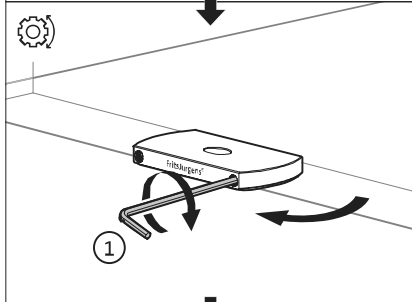
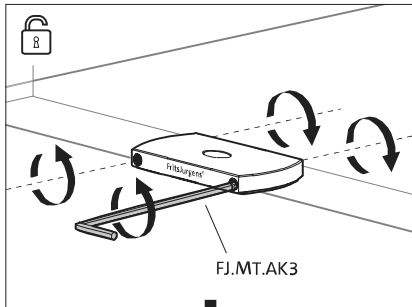
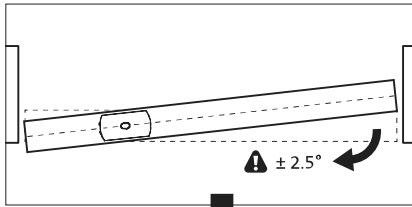

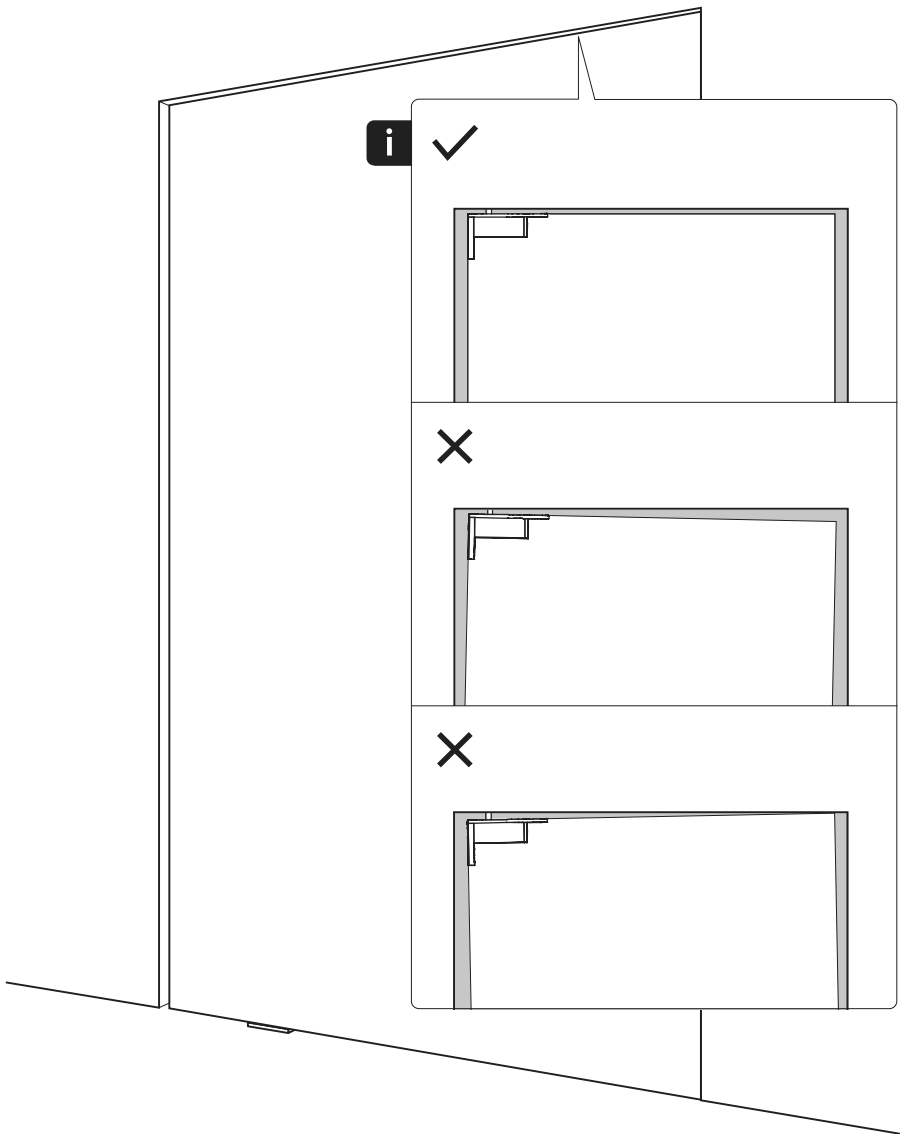

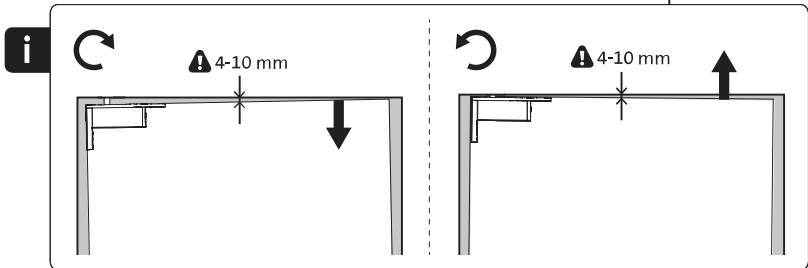
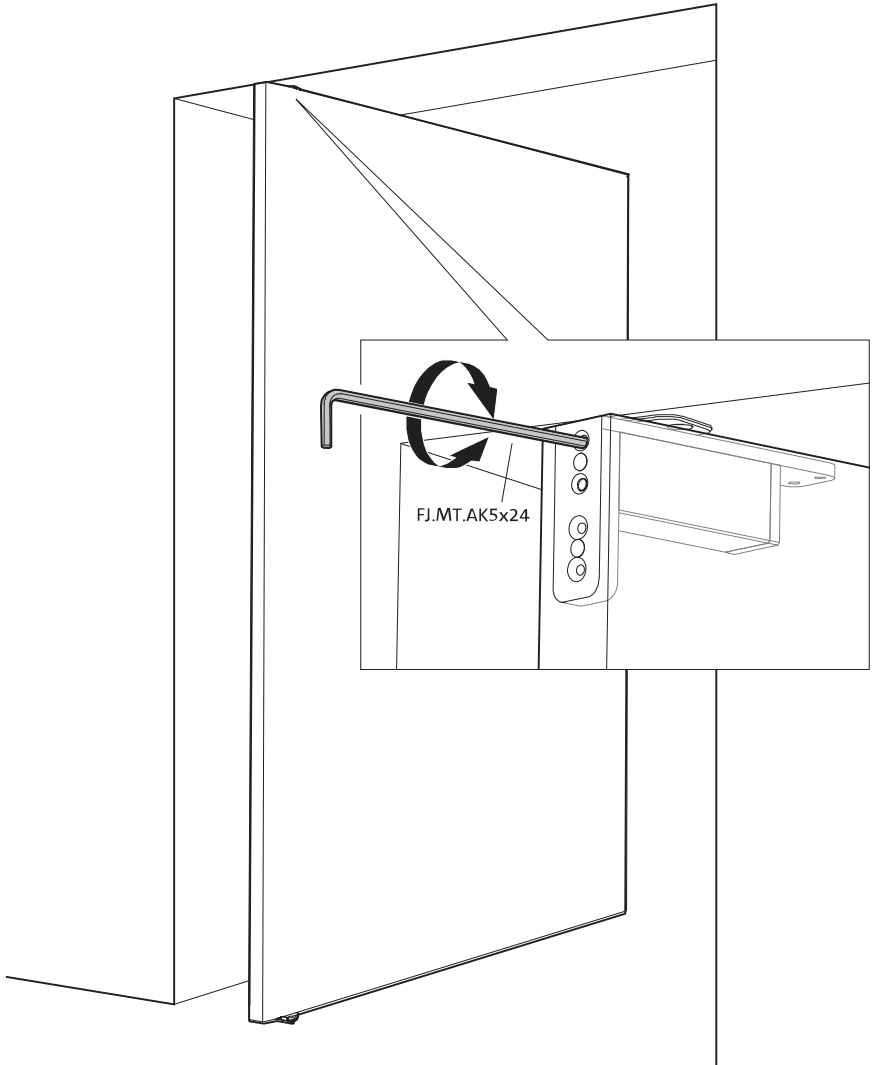

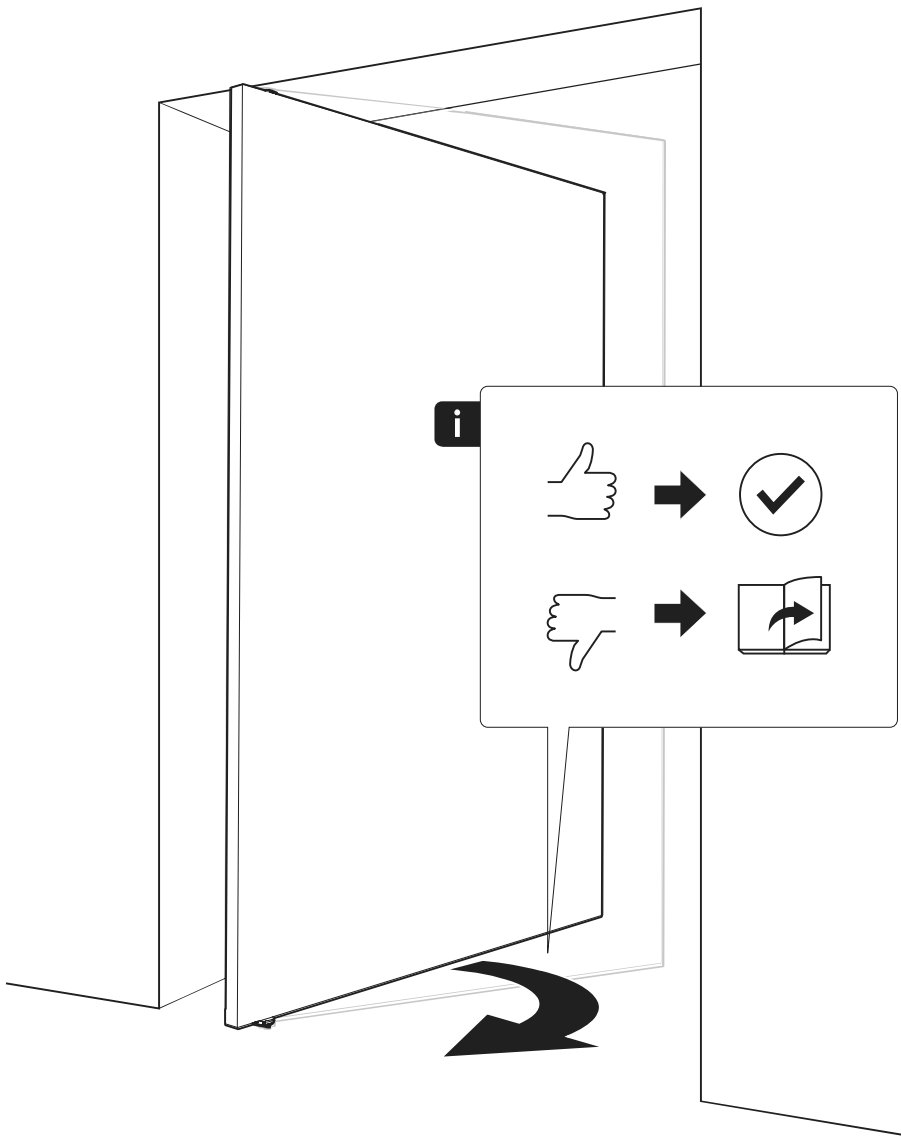



FJ.MT.AC.M+

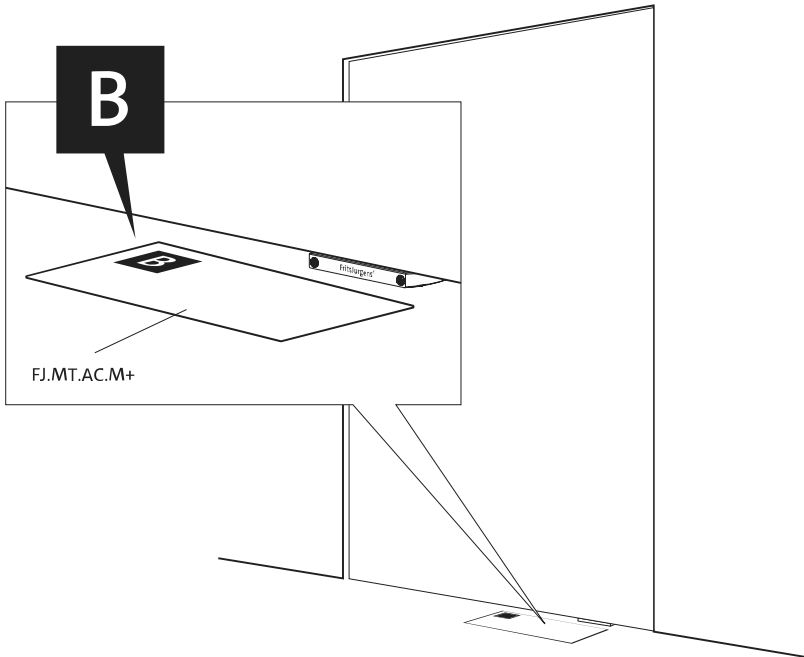
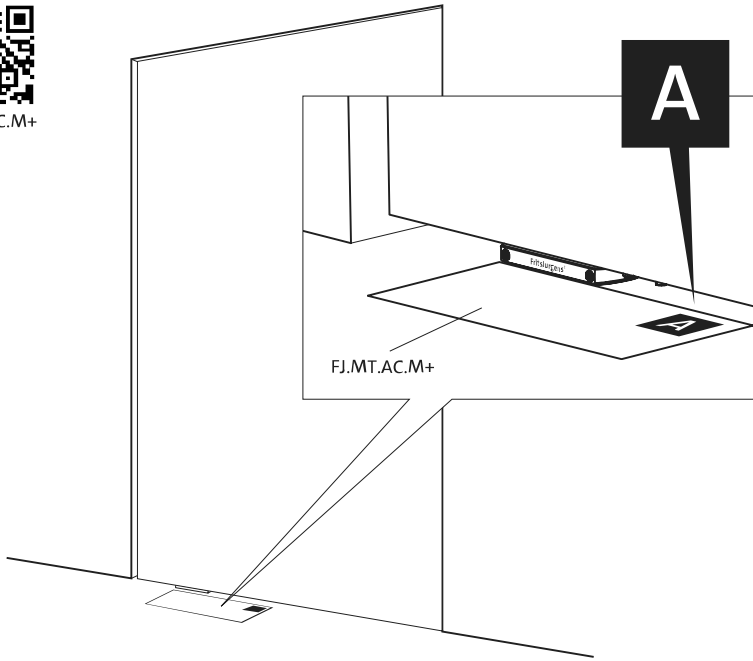

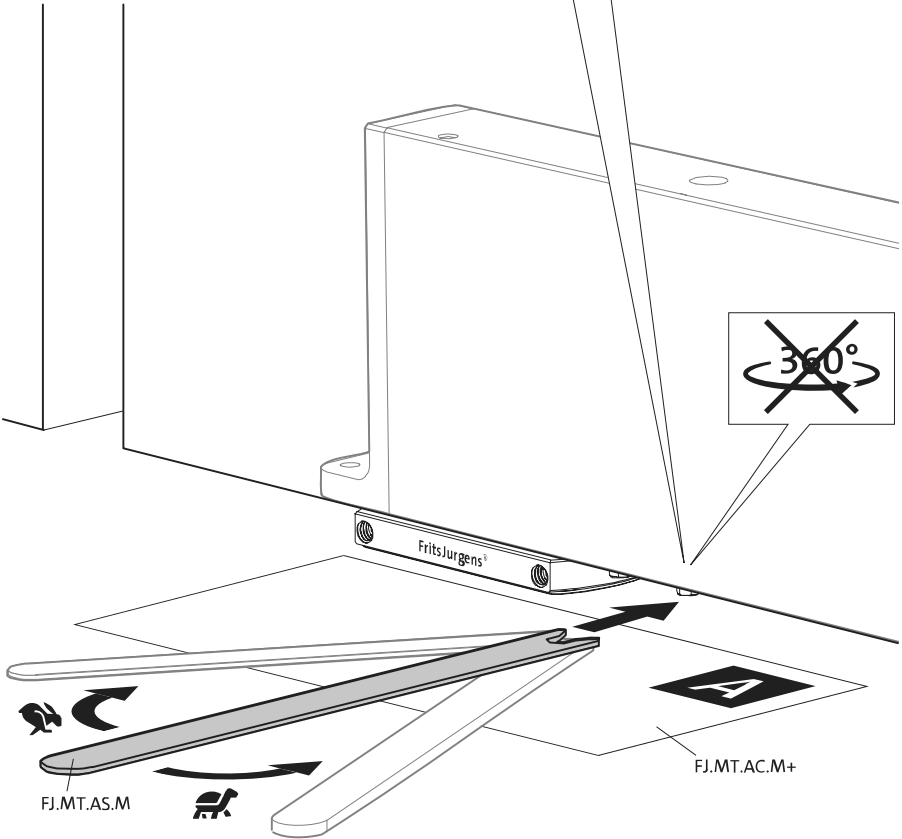
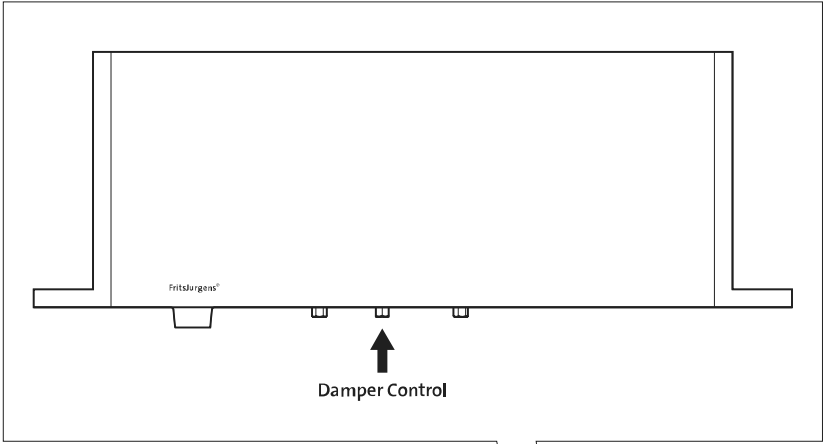

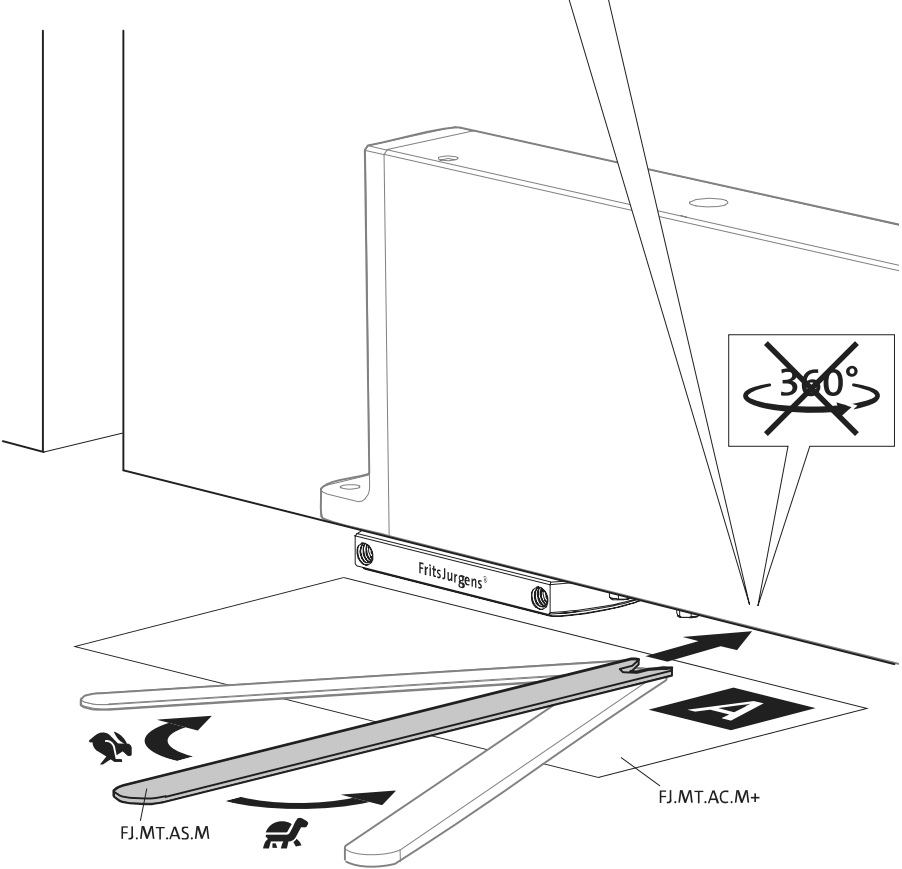
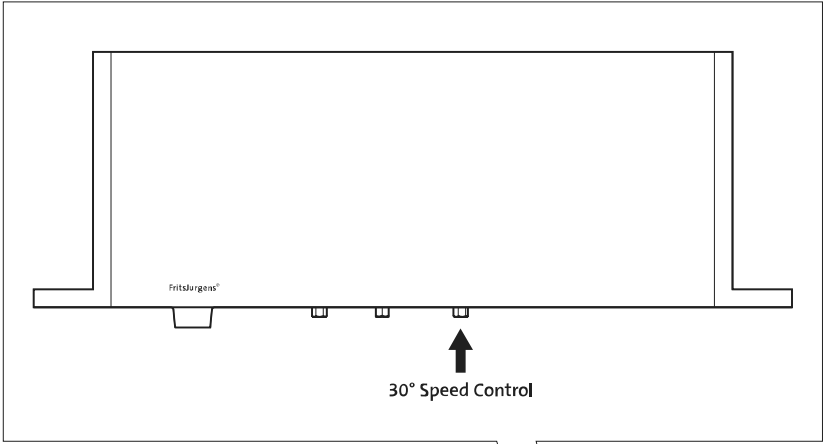

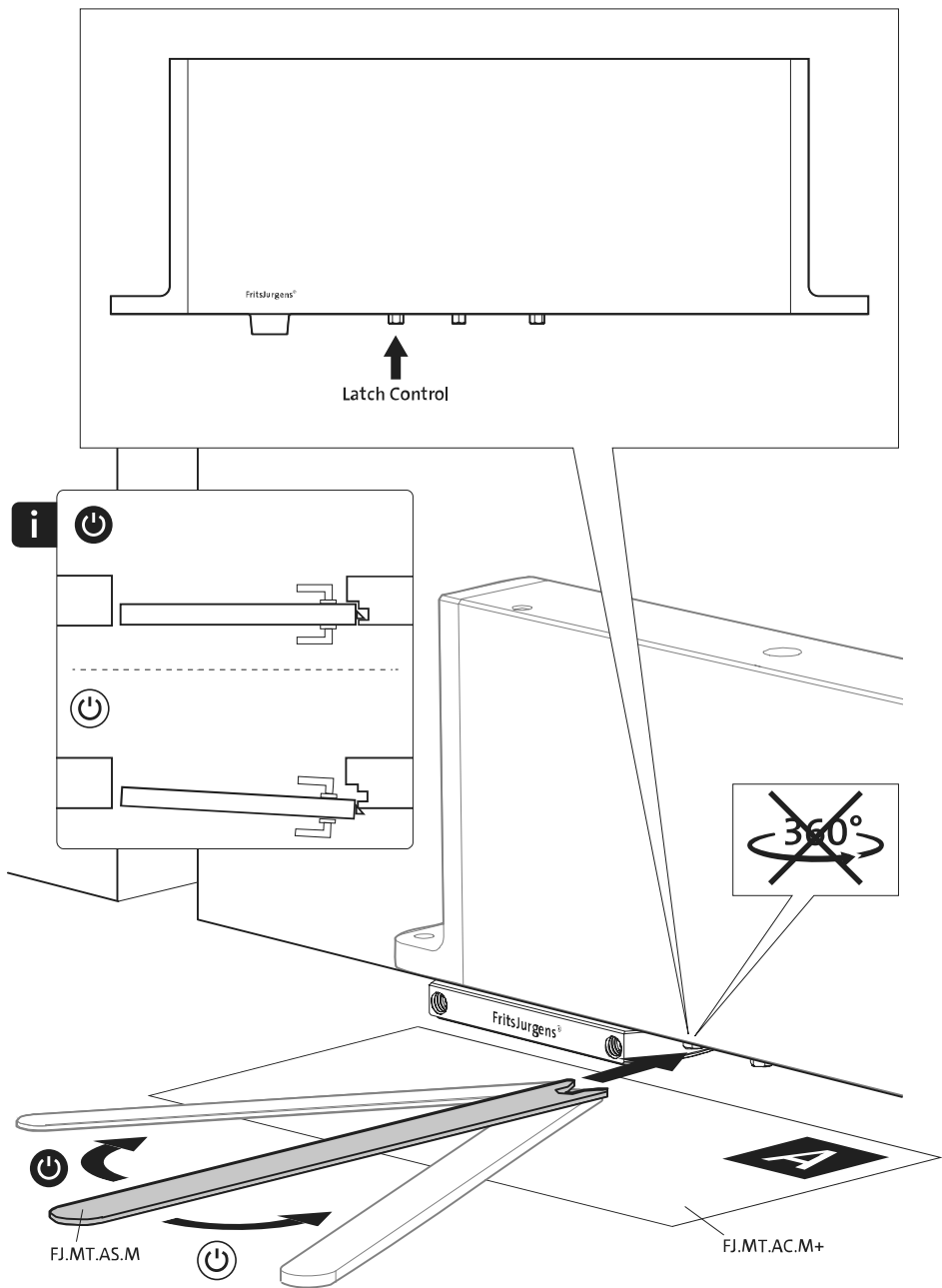



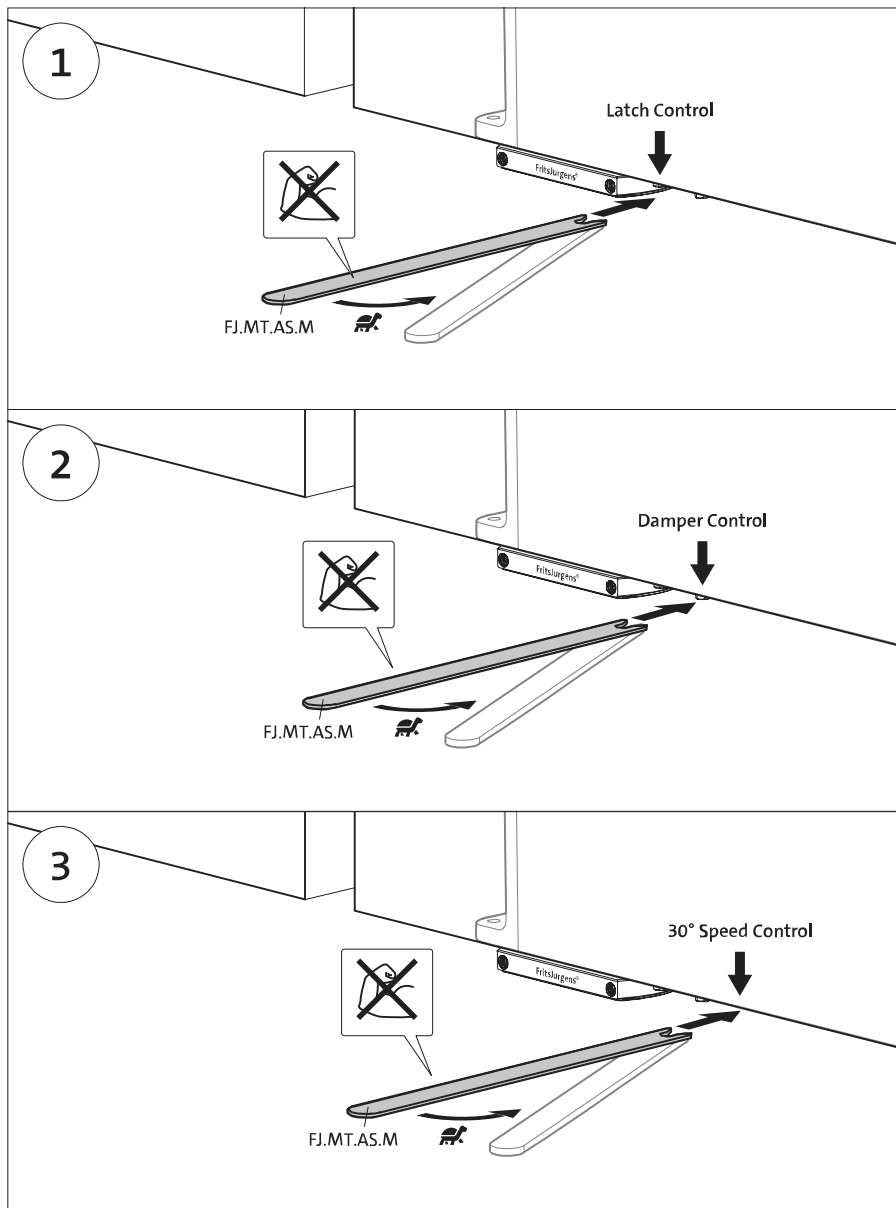

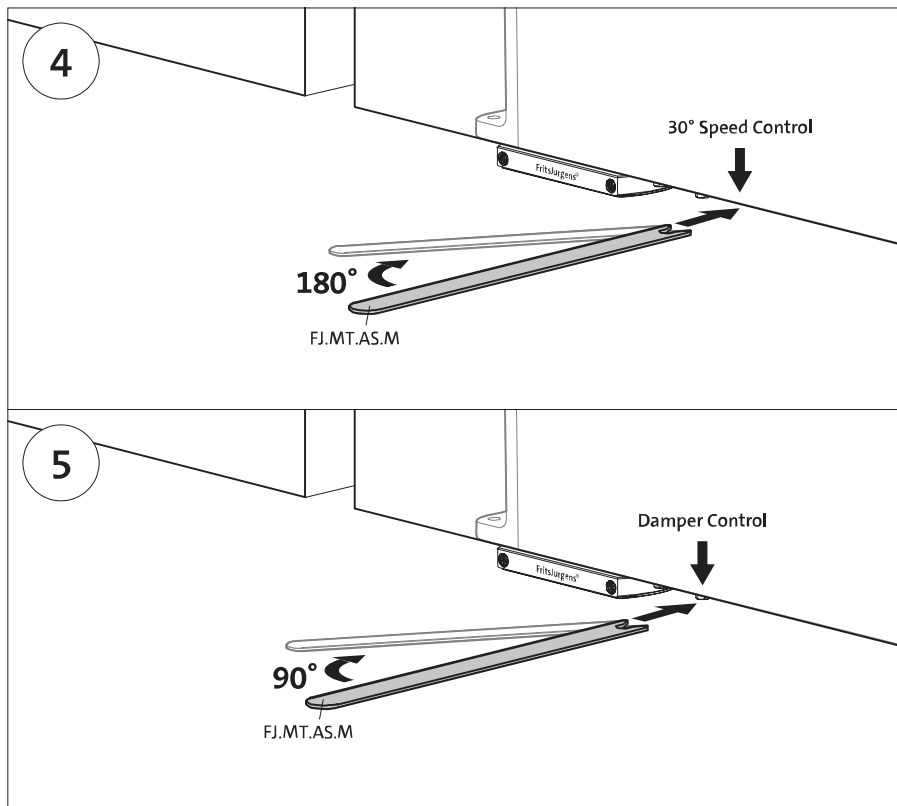

# Disassembly instructions

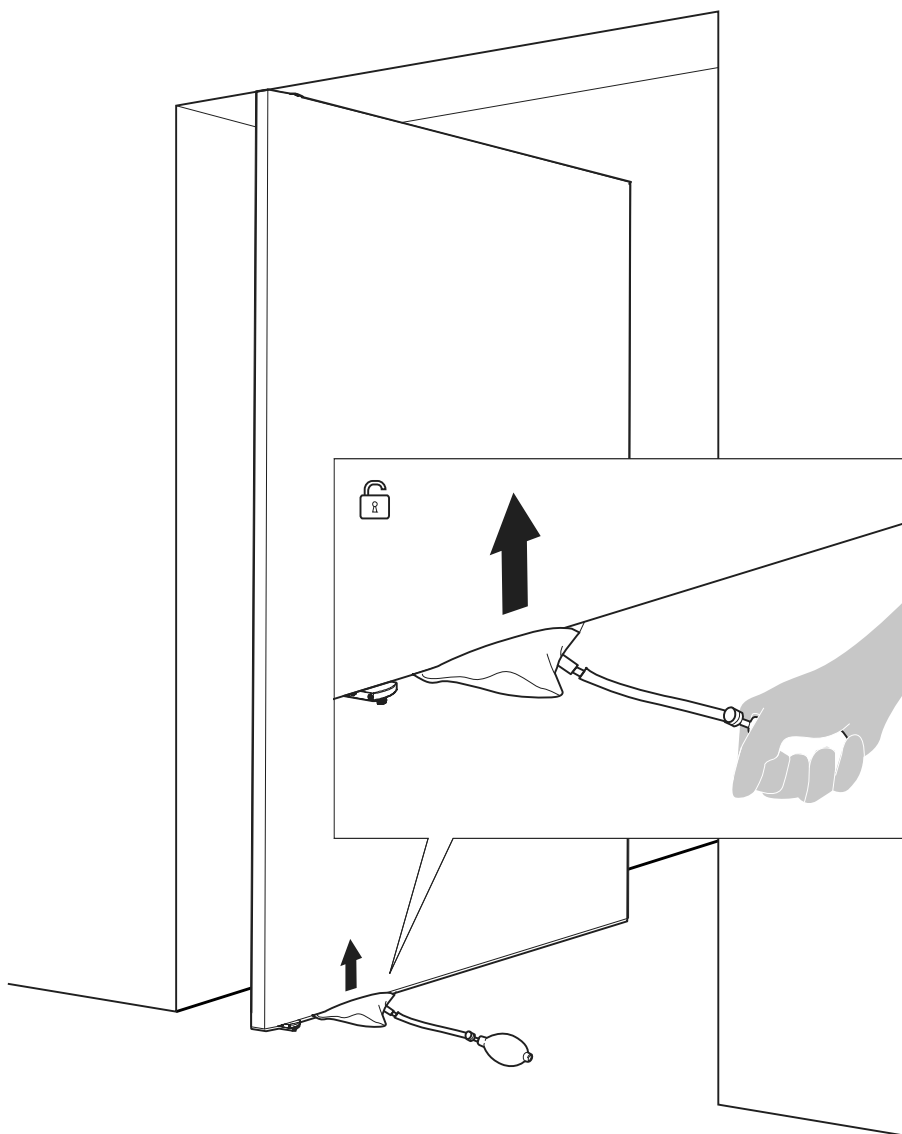

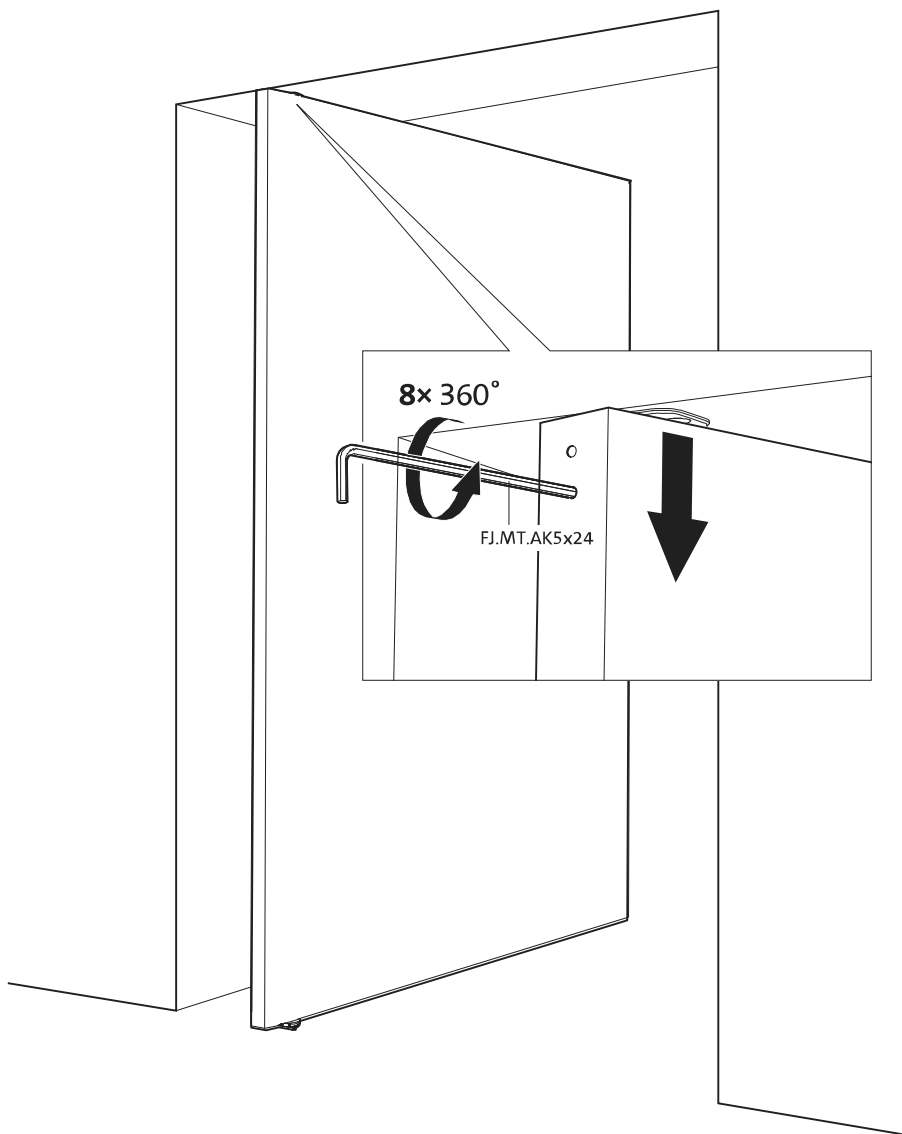





**FritsJurgens International**

A. Einsteinlaan 1  
The Netherlands  
9615 TE Kolham  
+31 598 343 410  
info@fritsjurgens.com

**FritsJurgens Dubai Branch**

DLC-OP-A2-4-0029  
Dubai South  
Dubai  
United Arab Emirates  
+971 4 820 8106  
+971 58 137 2611  
dubai@fritsjurgens.com  
fritsjurgens.com

Copyright © FritsJurgens®  
B.P.M.+40.C.X.SS





