

System M+

Milling and mounting manual

FritsJurgens Set - 70 mm Class G - invisible

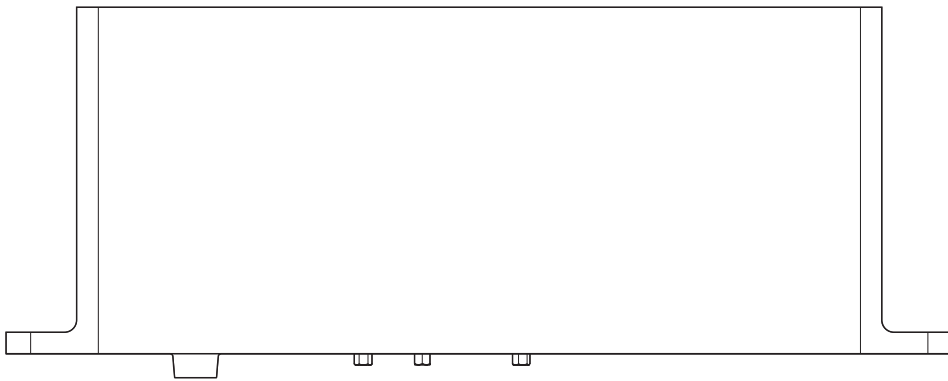

FritsJurgens®

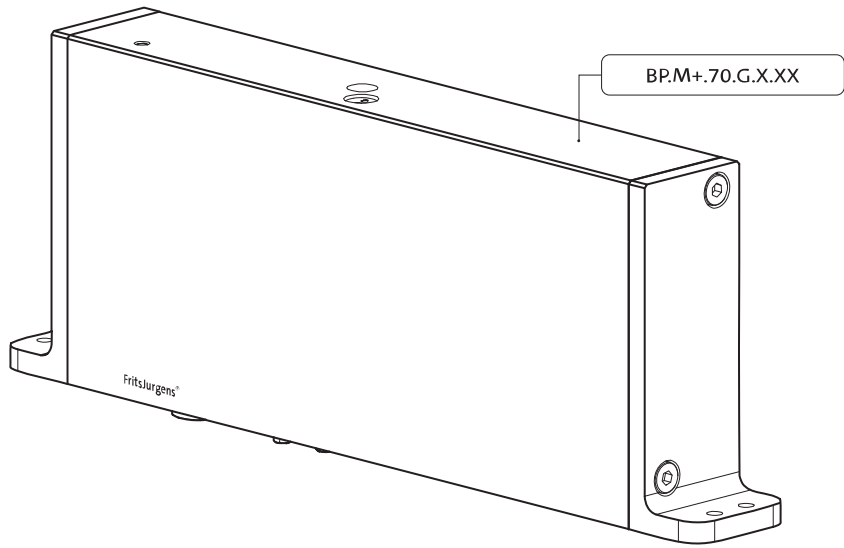
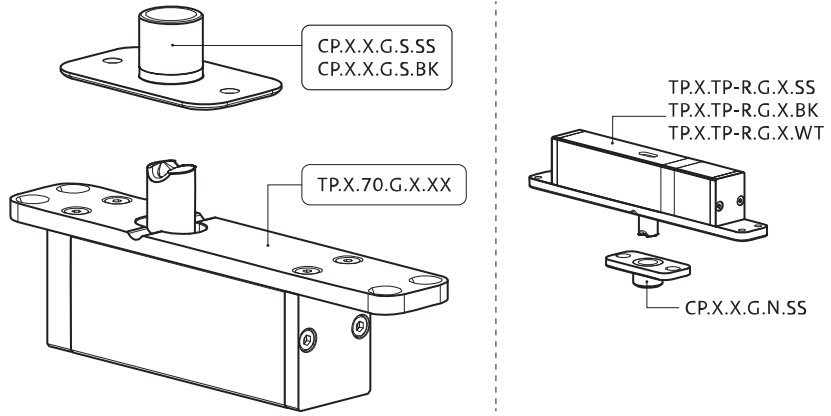

Milling instructions

BP.M+.70.G.X.XX

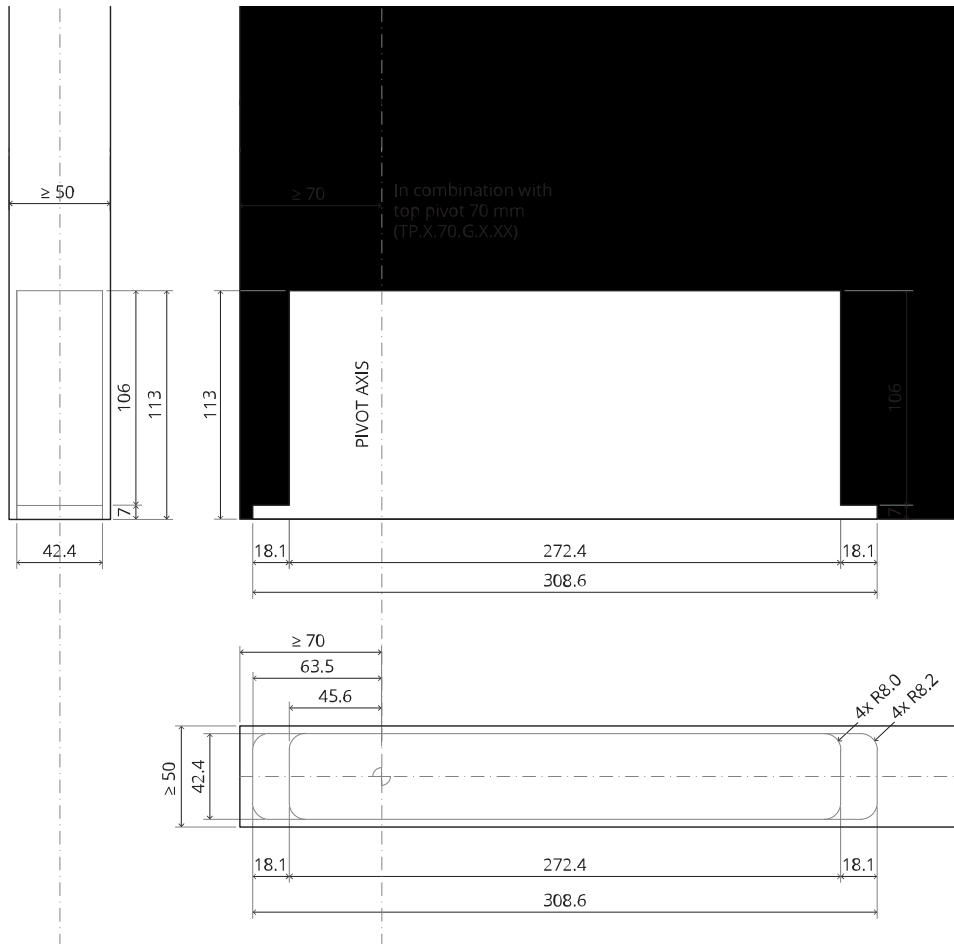

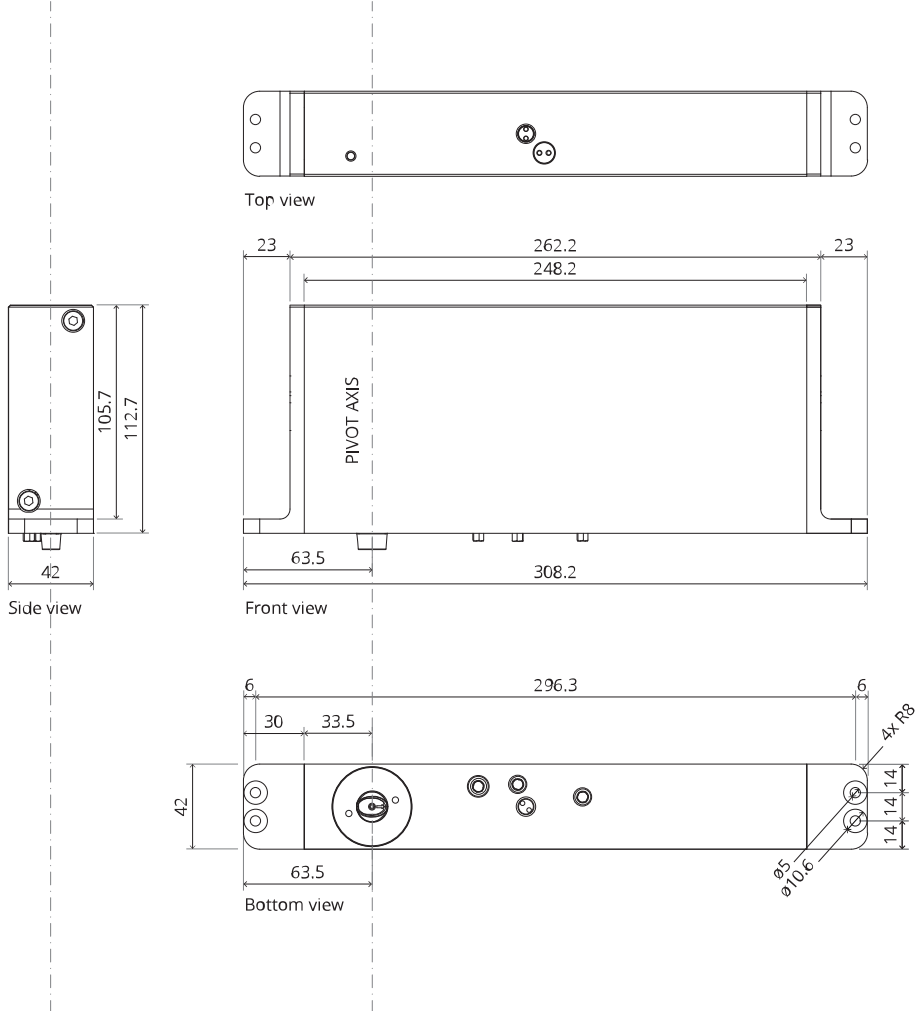

TP.X.70.G.X.XX

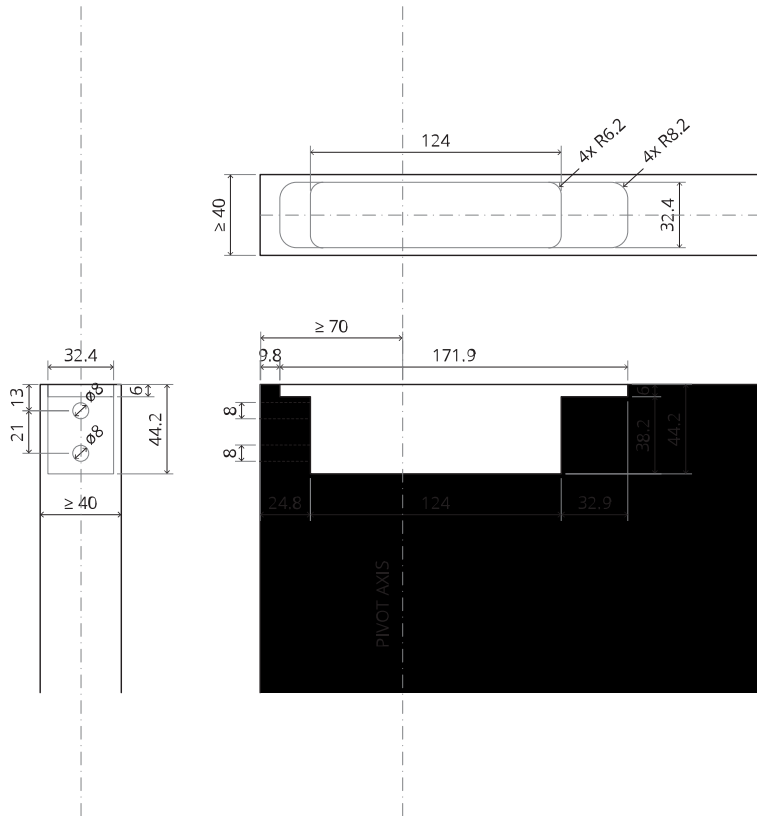

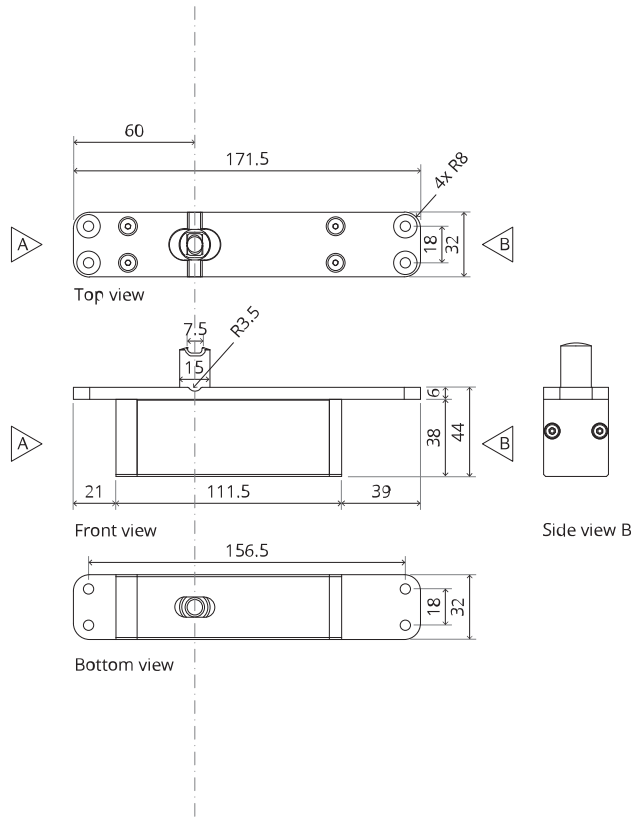
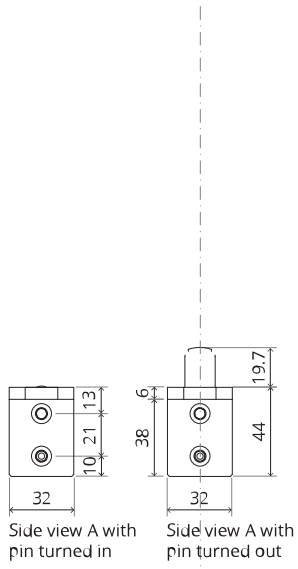

TP.X.TP-R.G.X. __

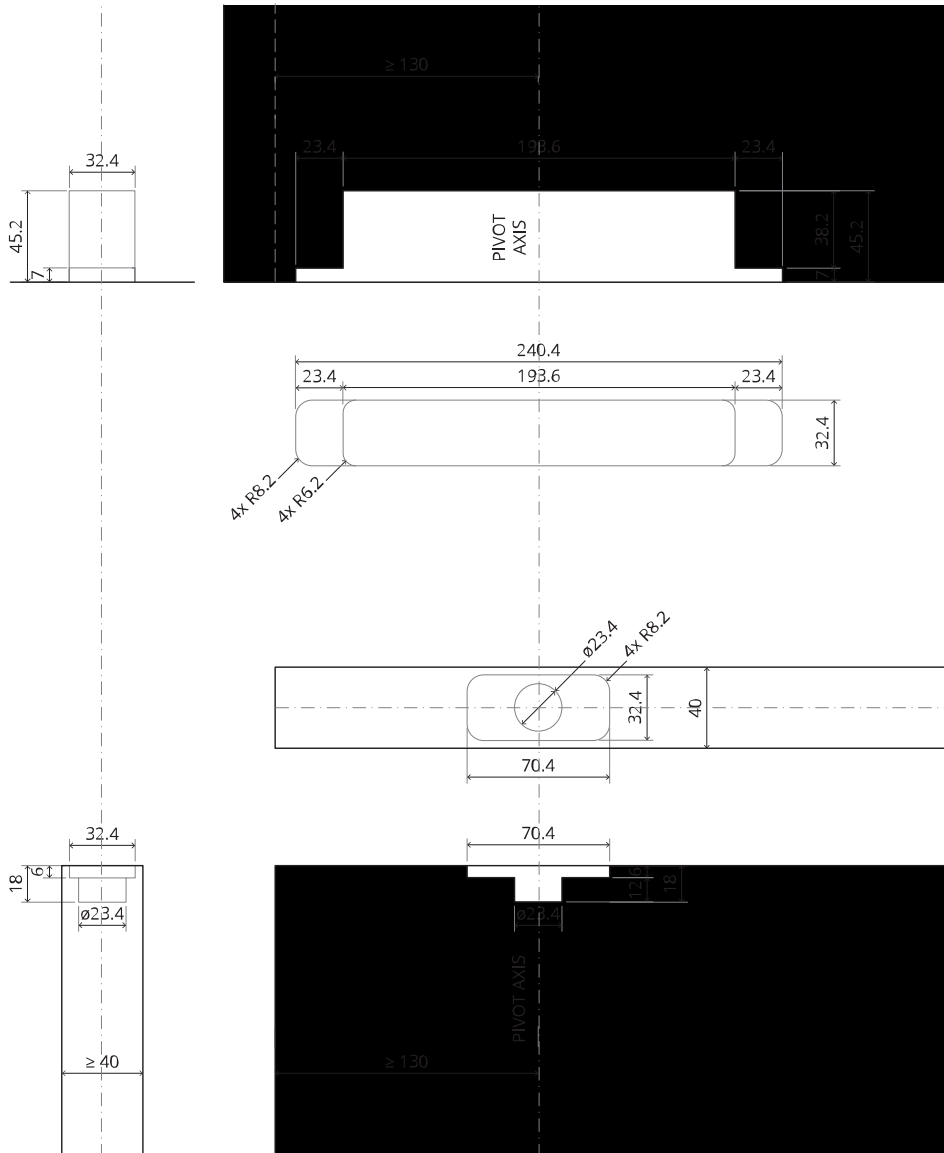

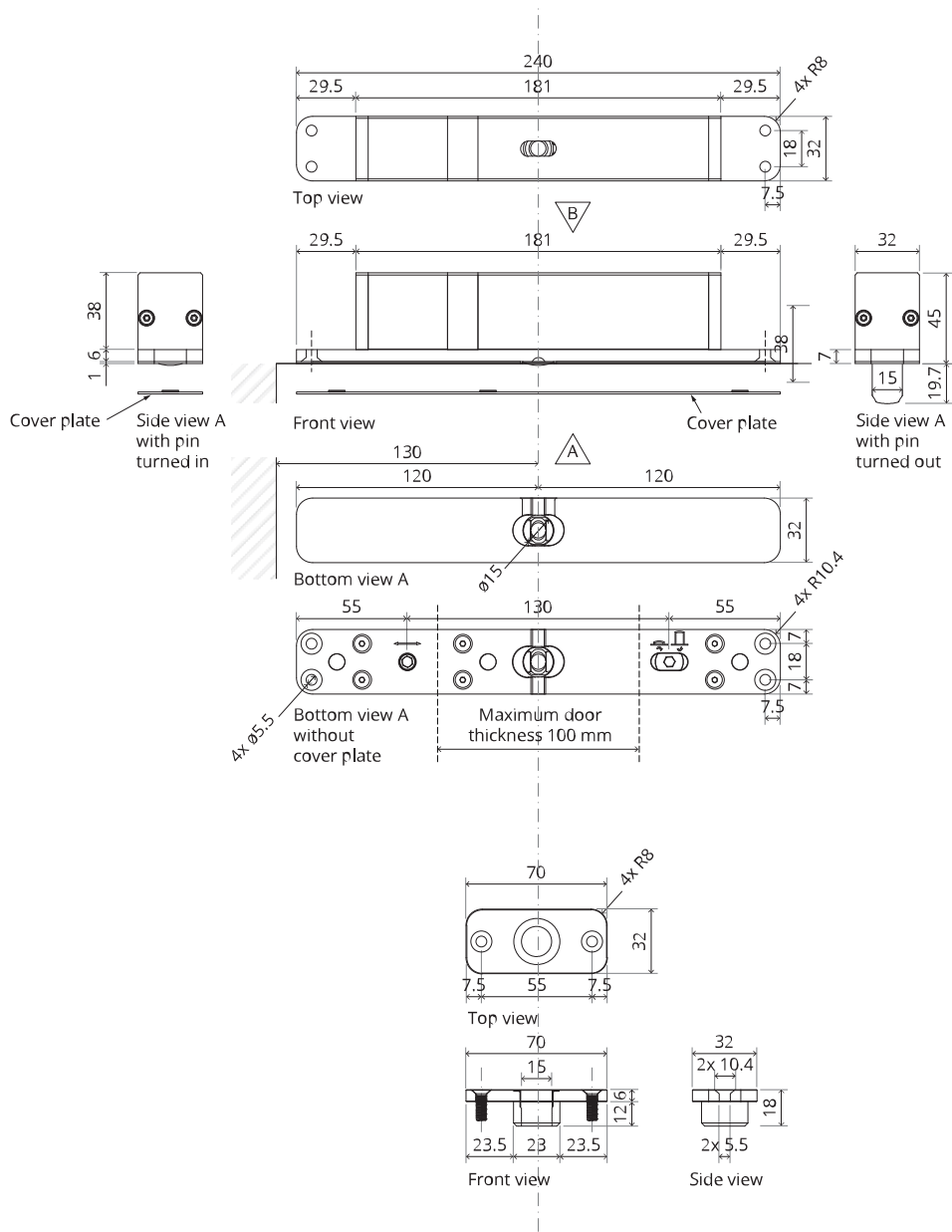

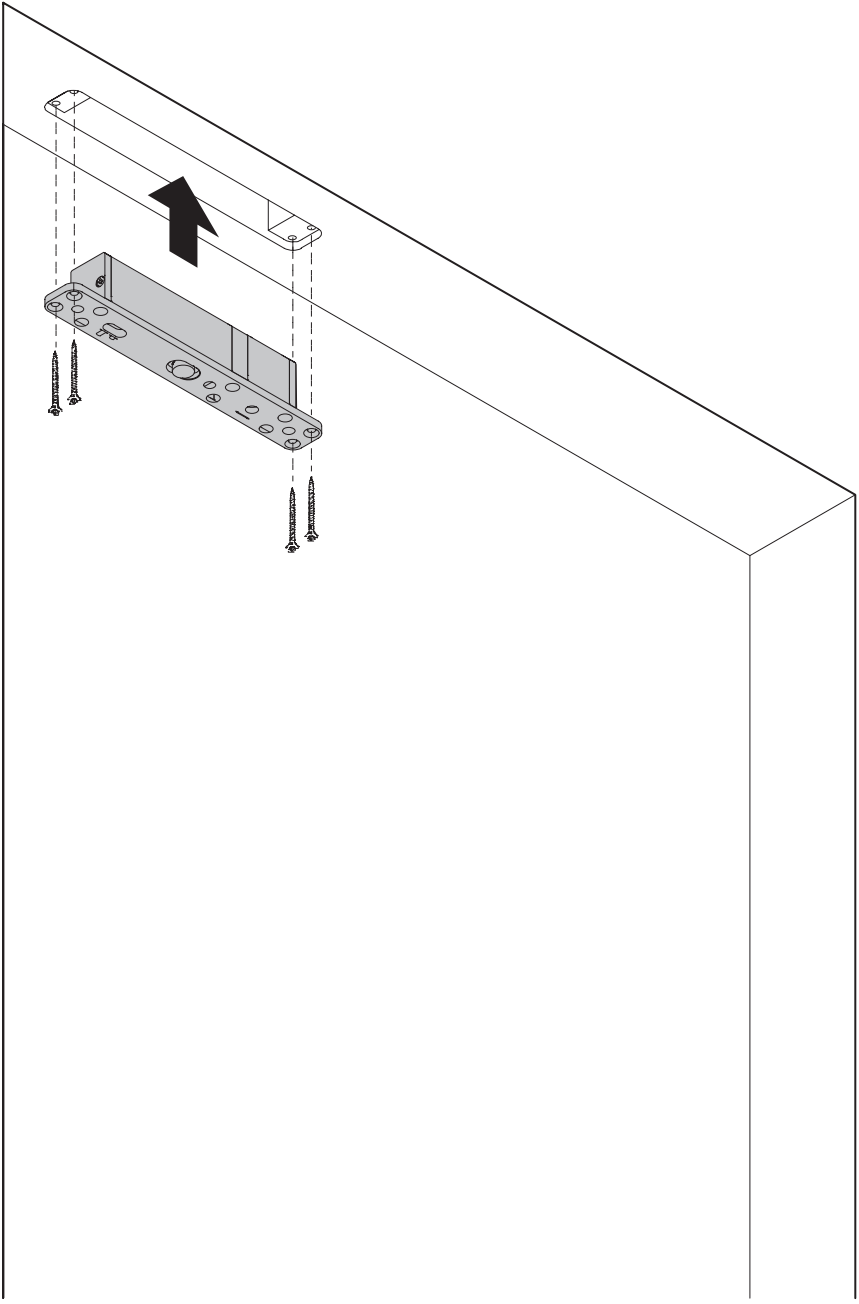

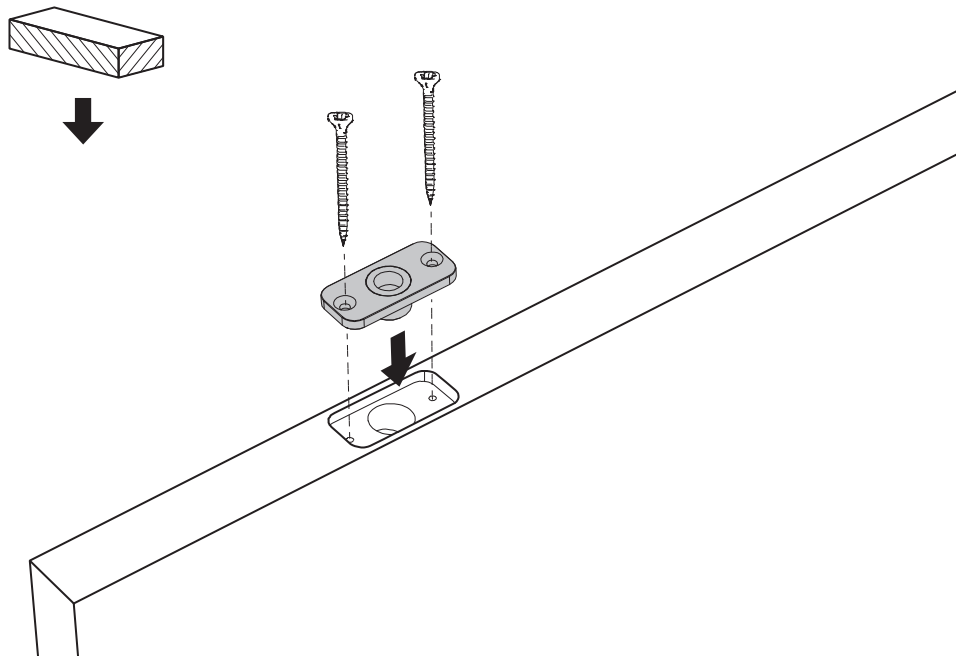
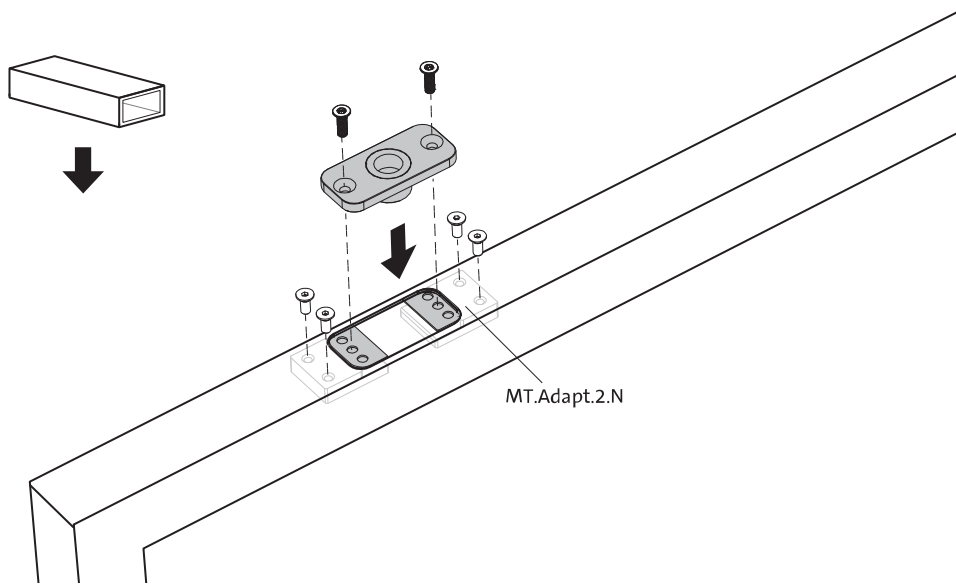

FP.M.X.X.FS.SS

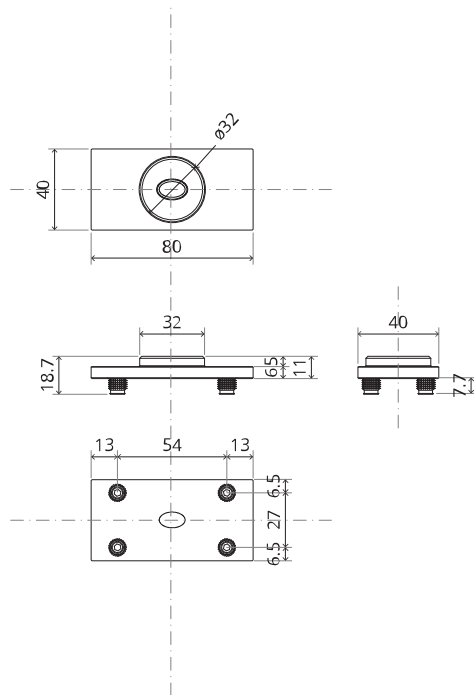
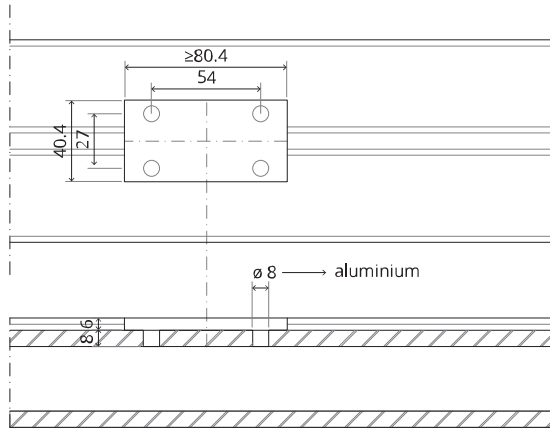

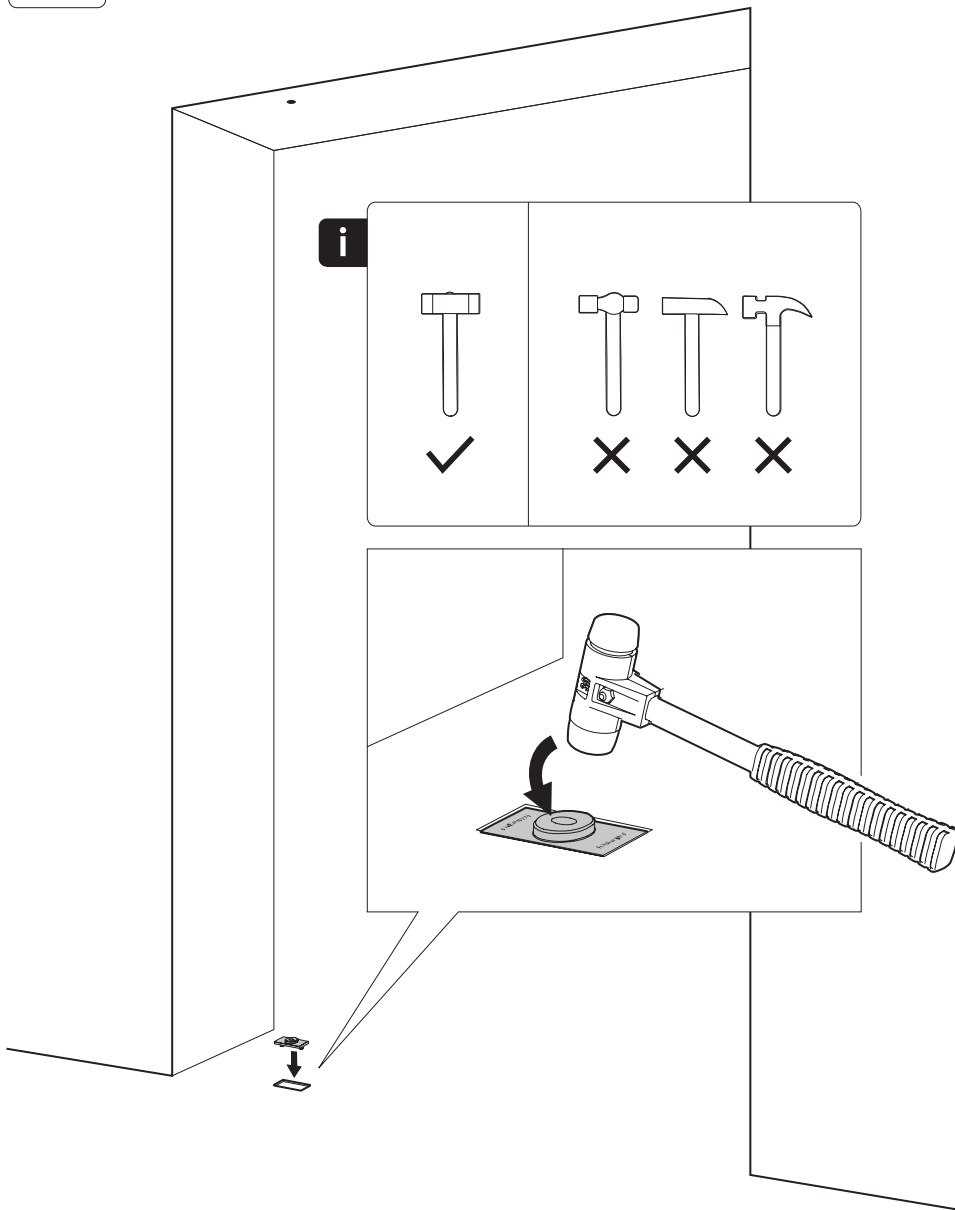

FP.M.X.X.FR.SS

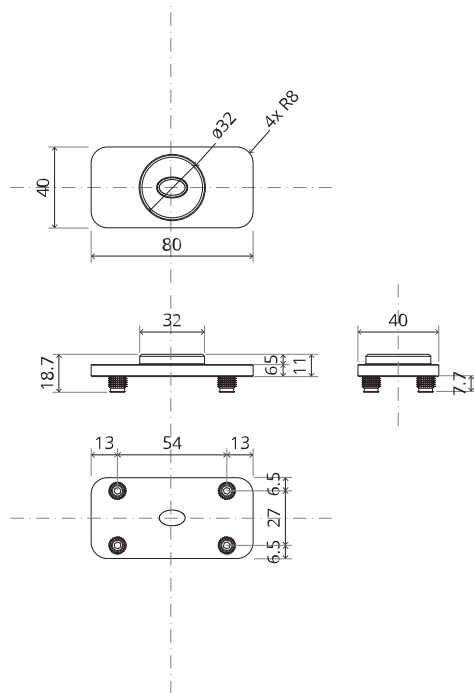
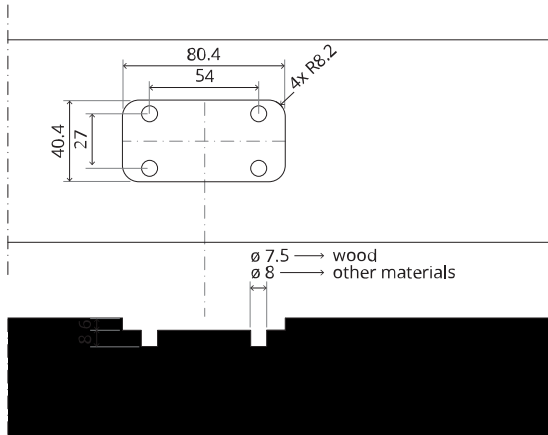

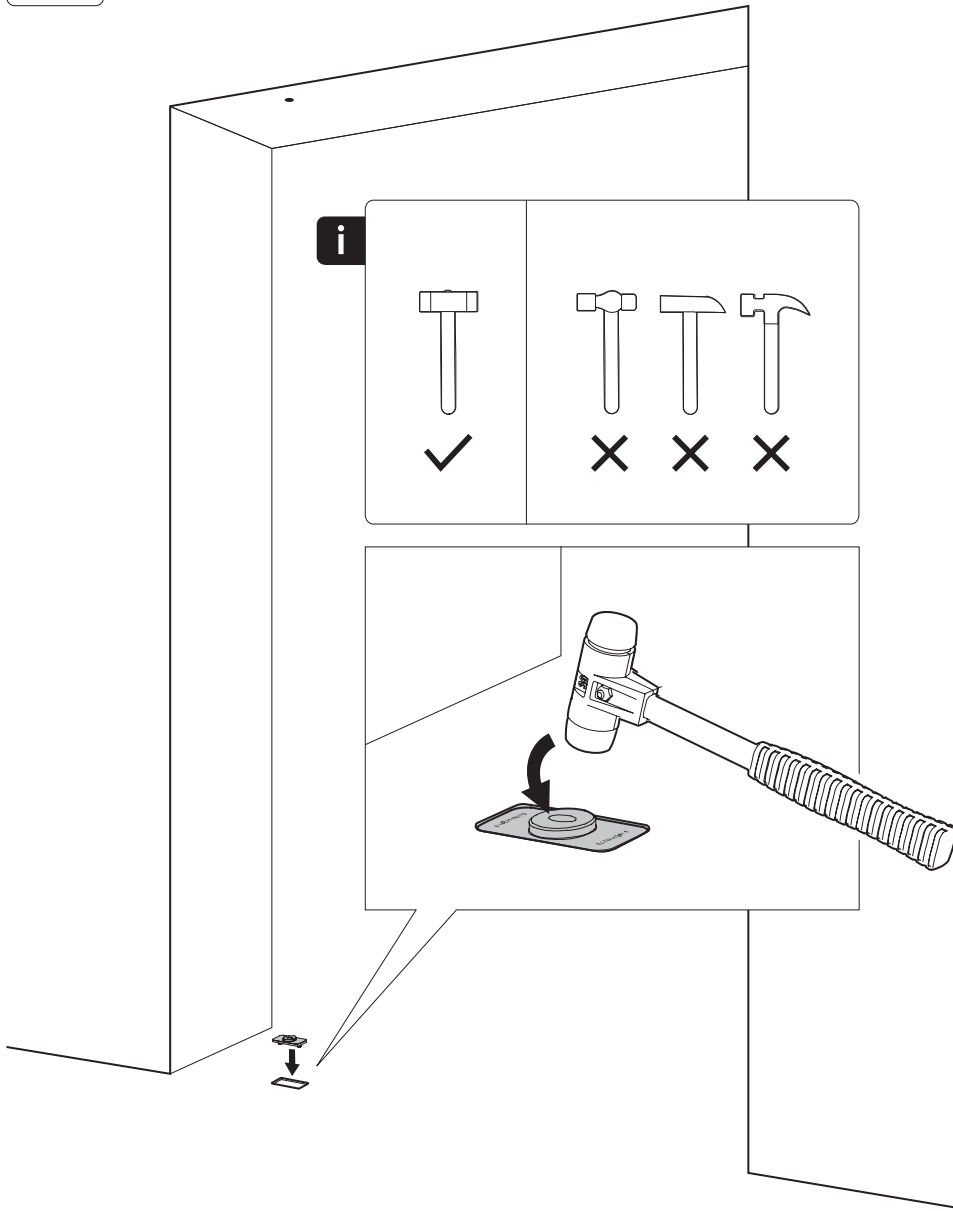

Mounting instructions

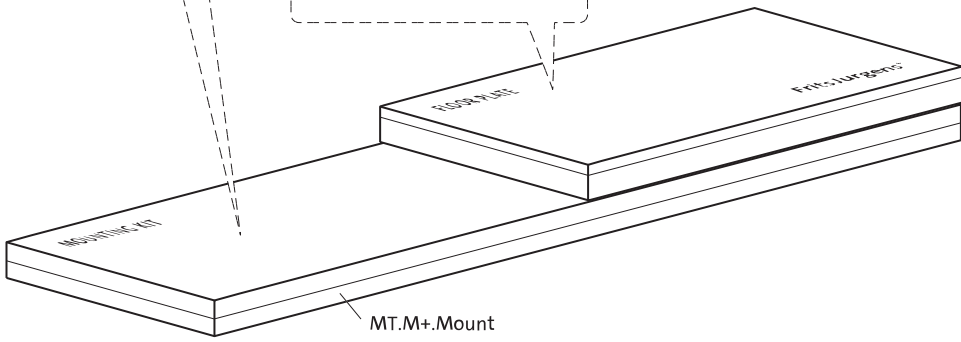
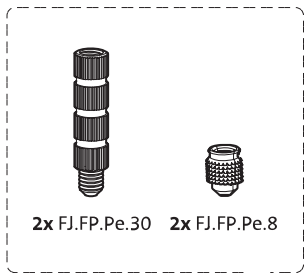
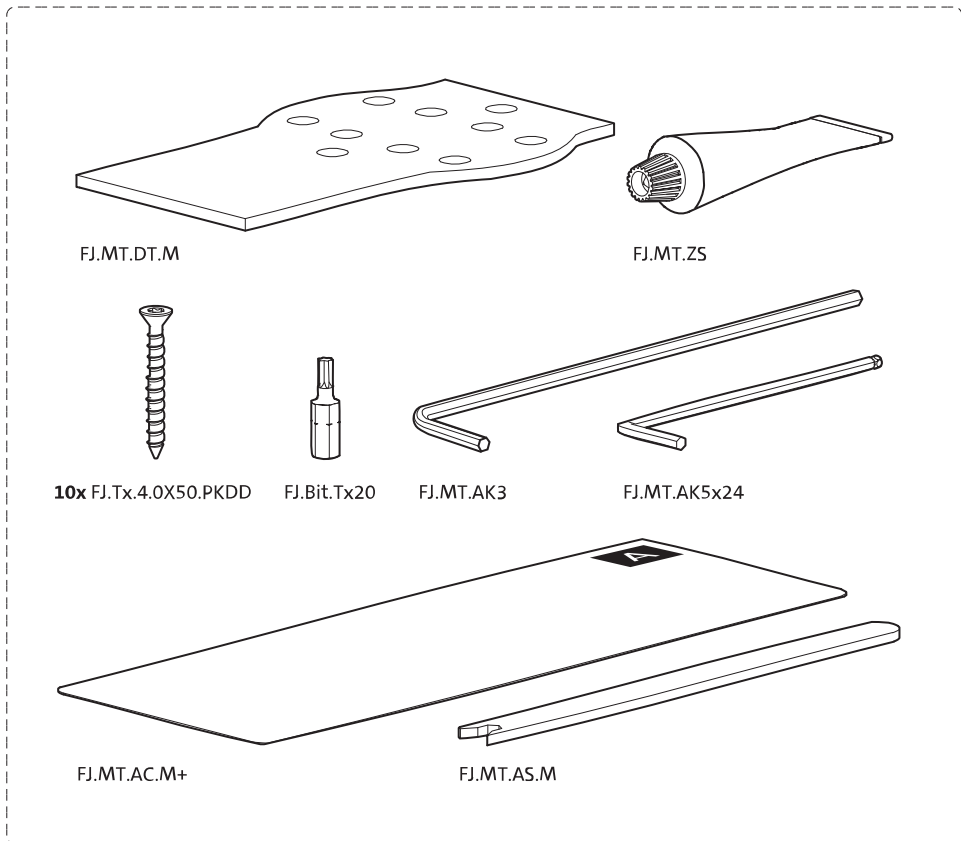

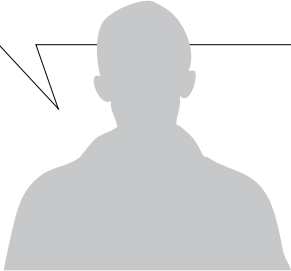
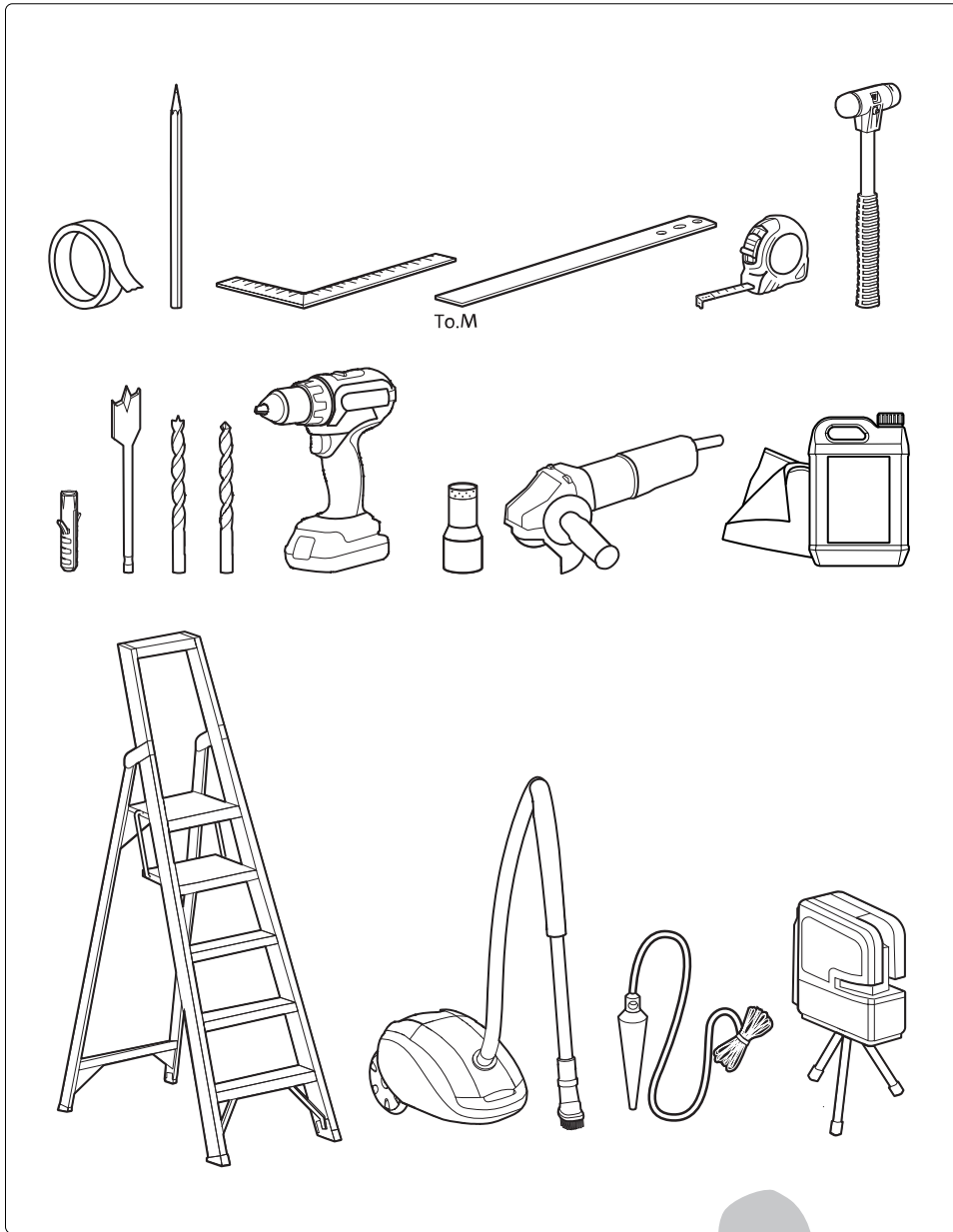

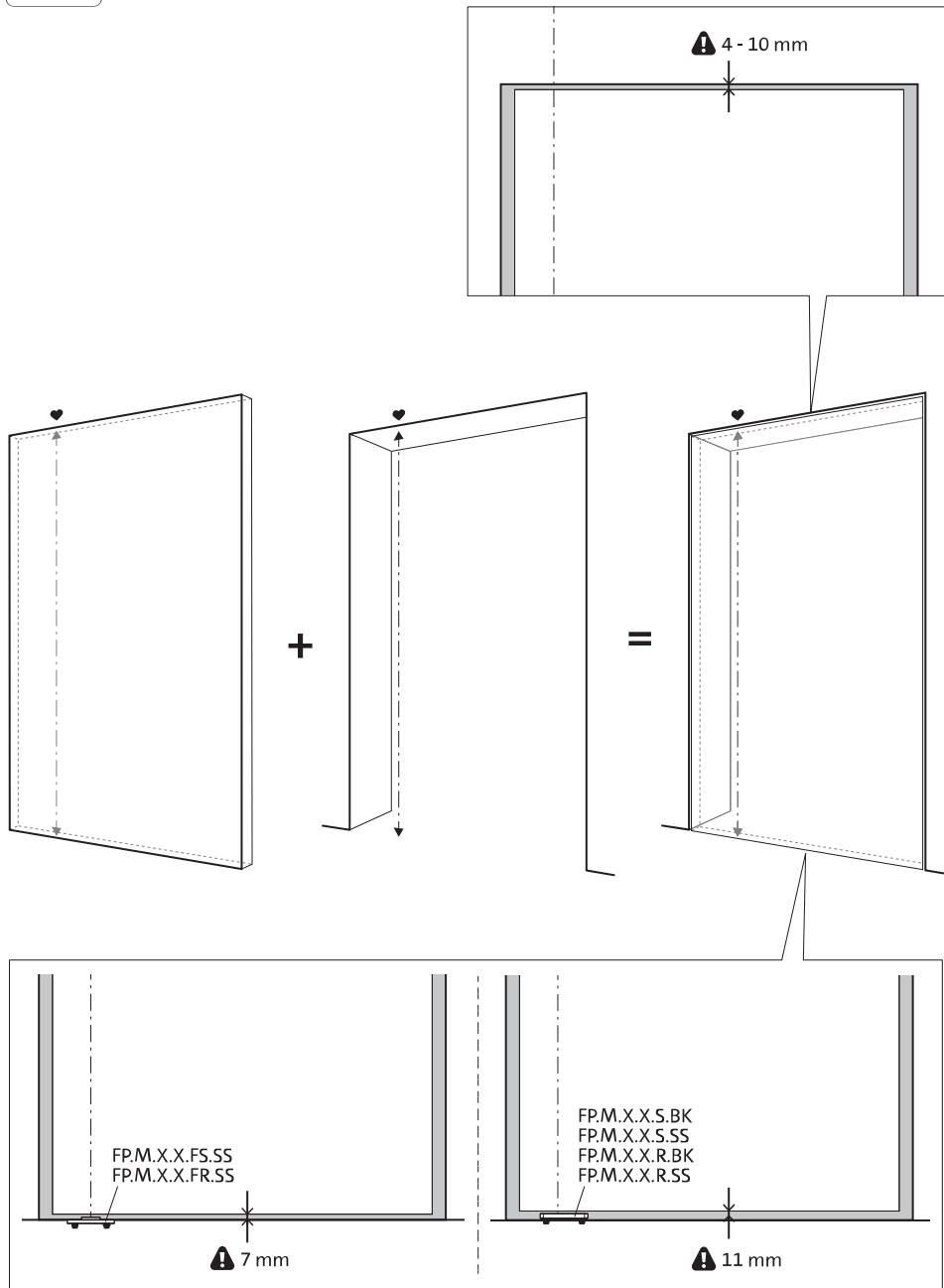

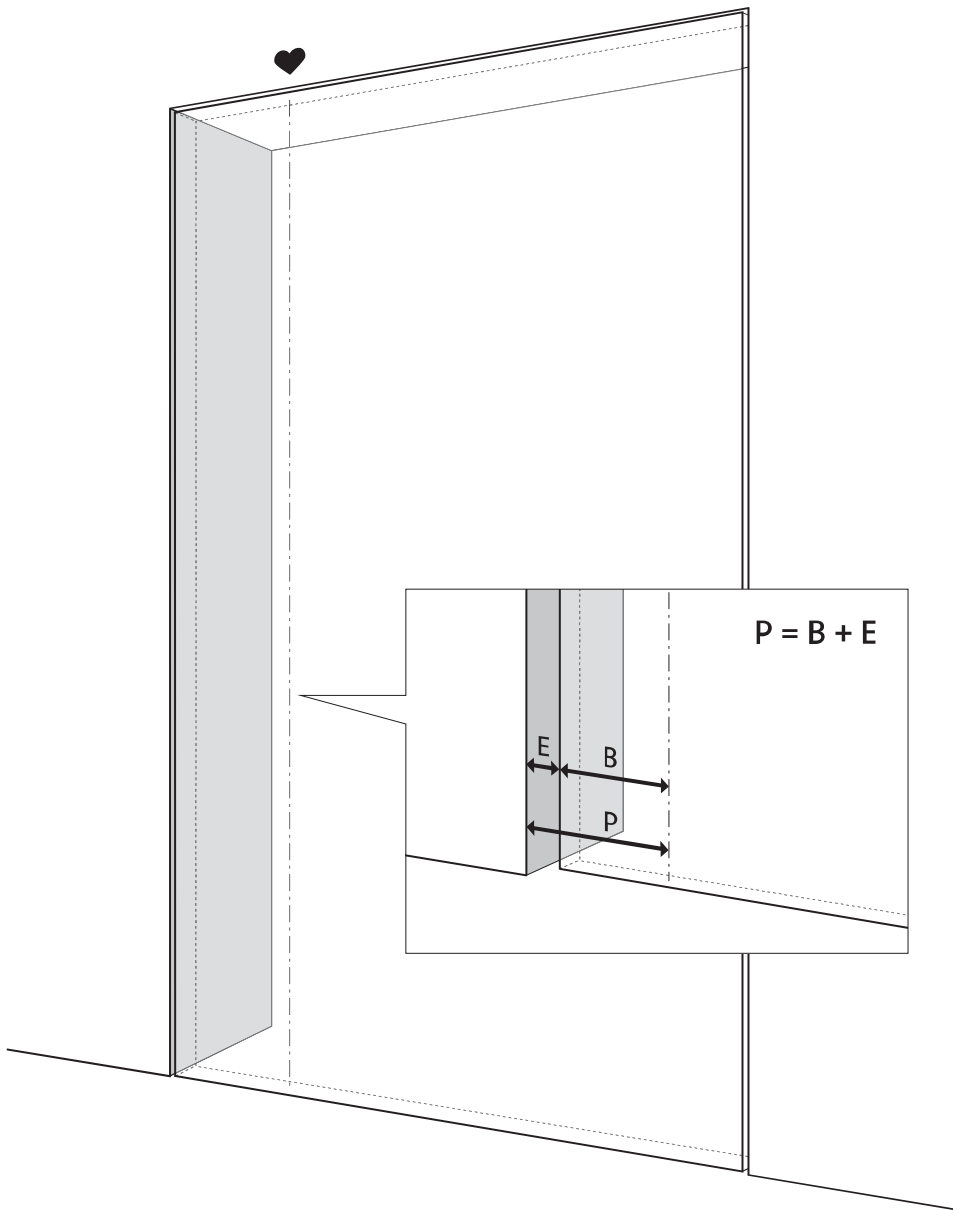

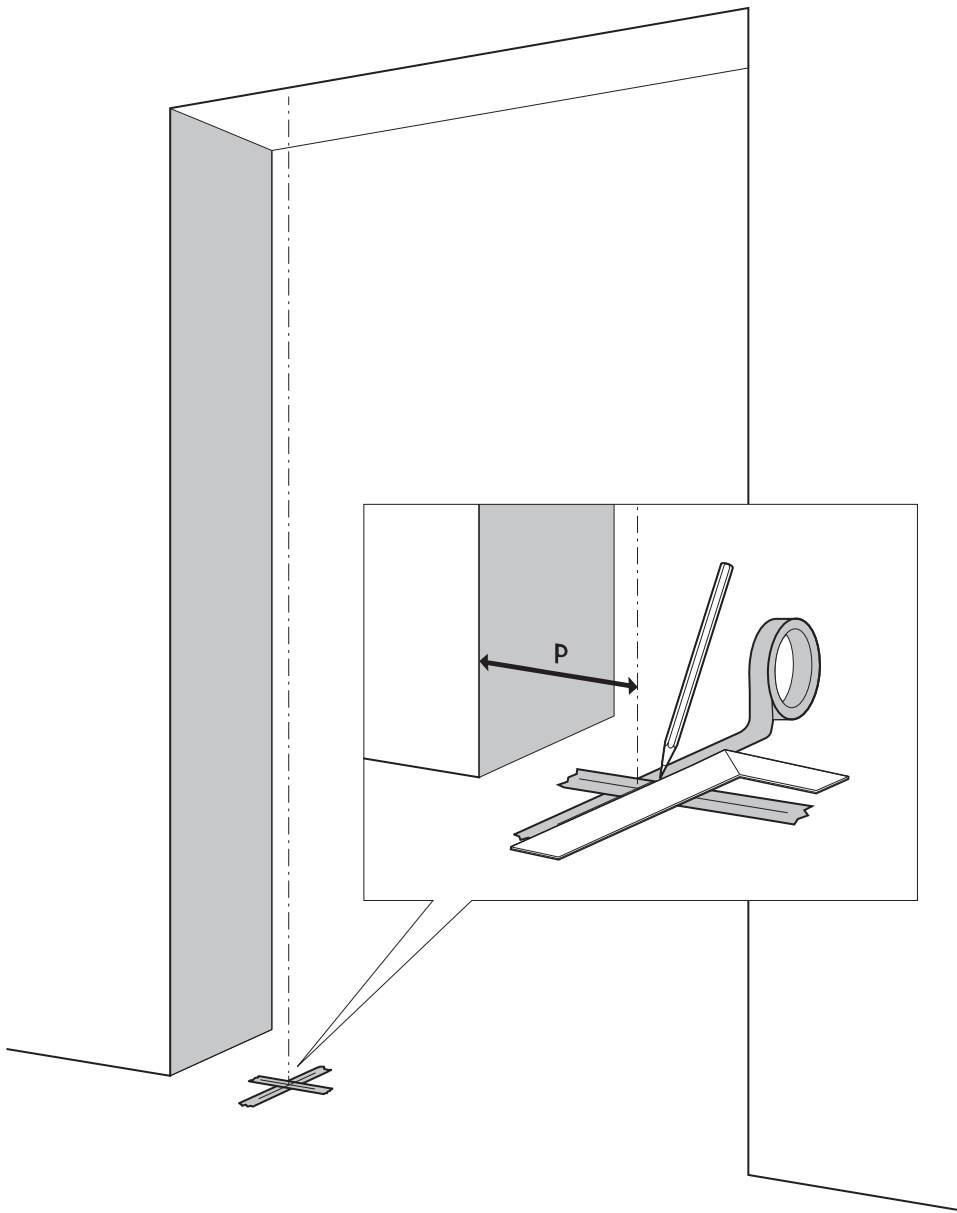

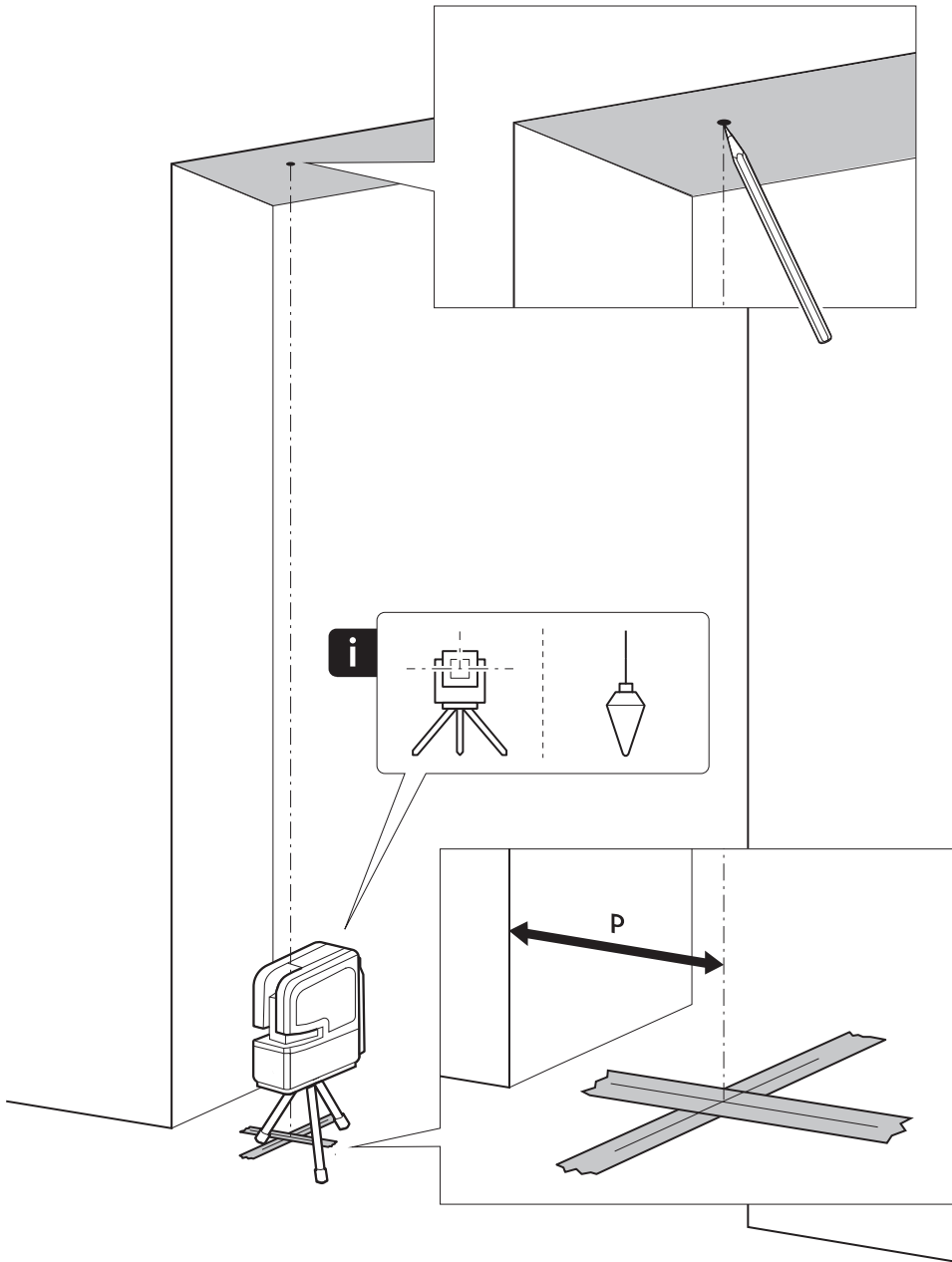
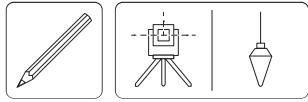

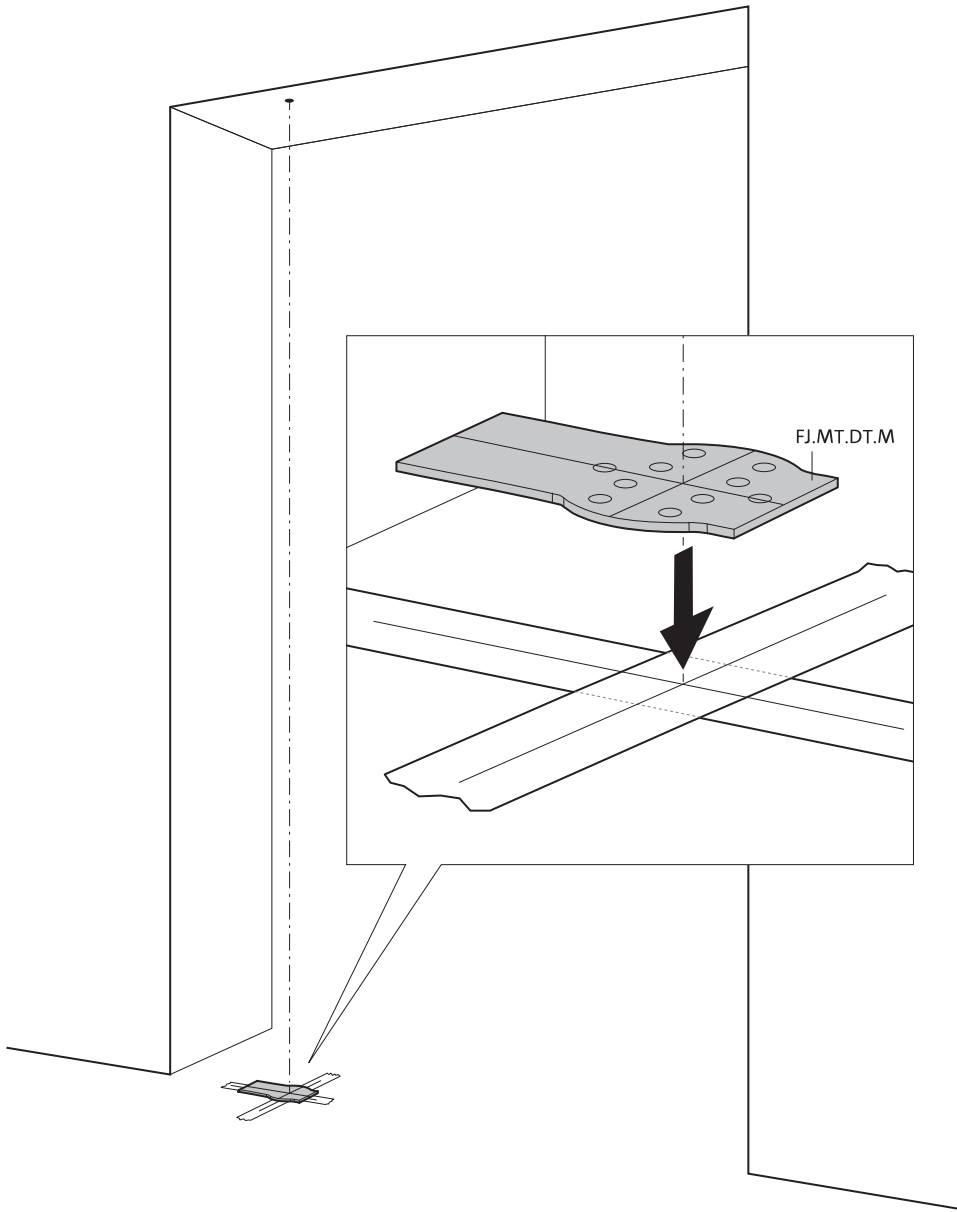

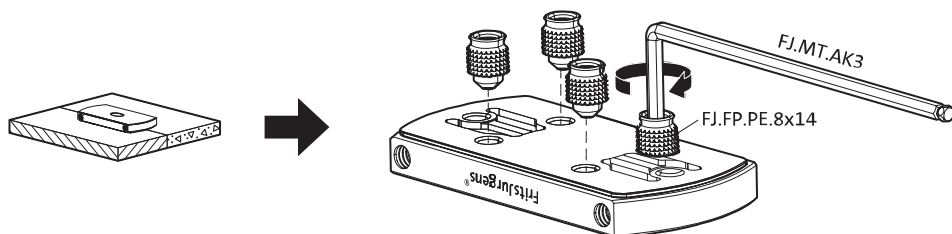
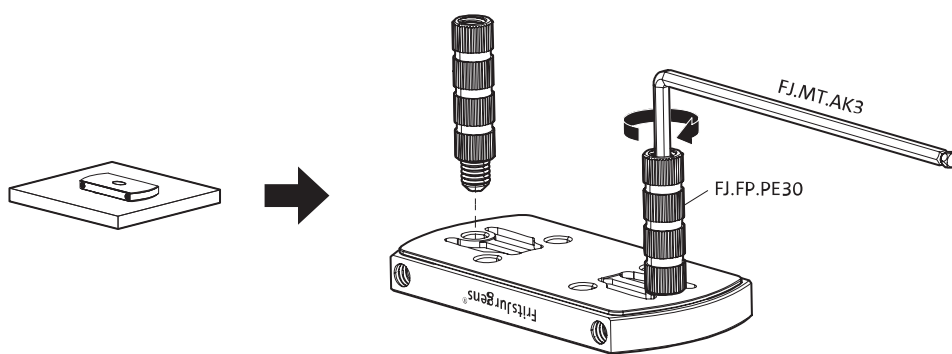
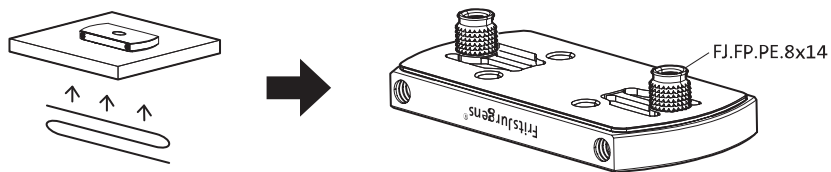



ø8 mm (5/16")

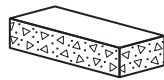

ø8 mm (5/16")

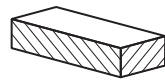

ø7.5 mm (19/64")

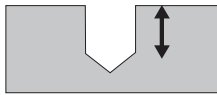

8 mm (5/16")

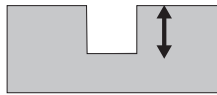

8 mm (5/16")

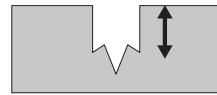

8 mm (5/16")

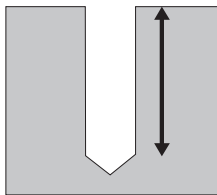

30 mm (13/16")

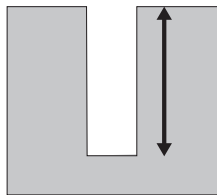

30 mm (13/16")

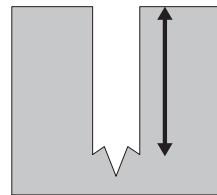

30 mm (13/16")

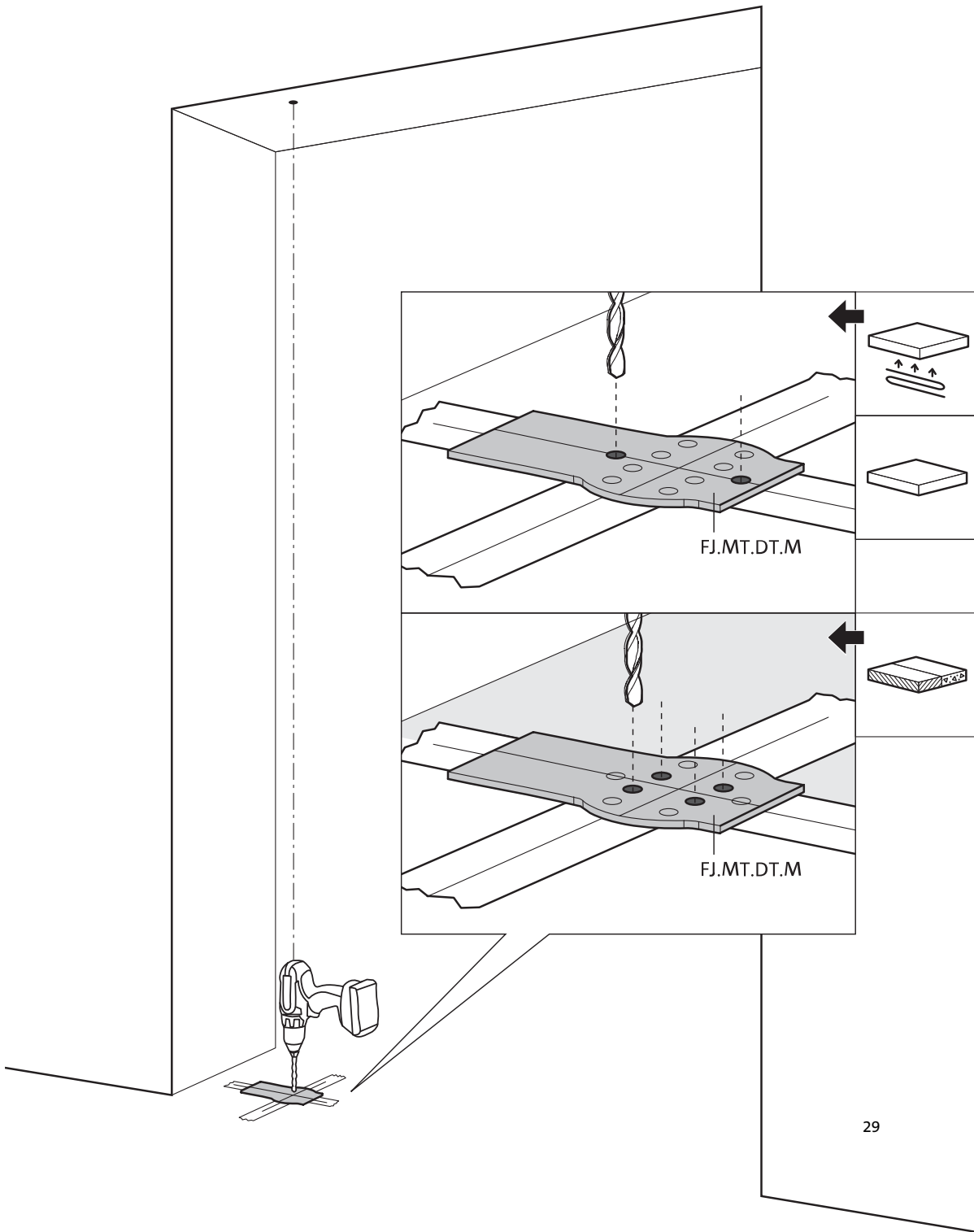
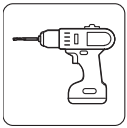

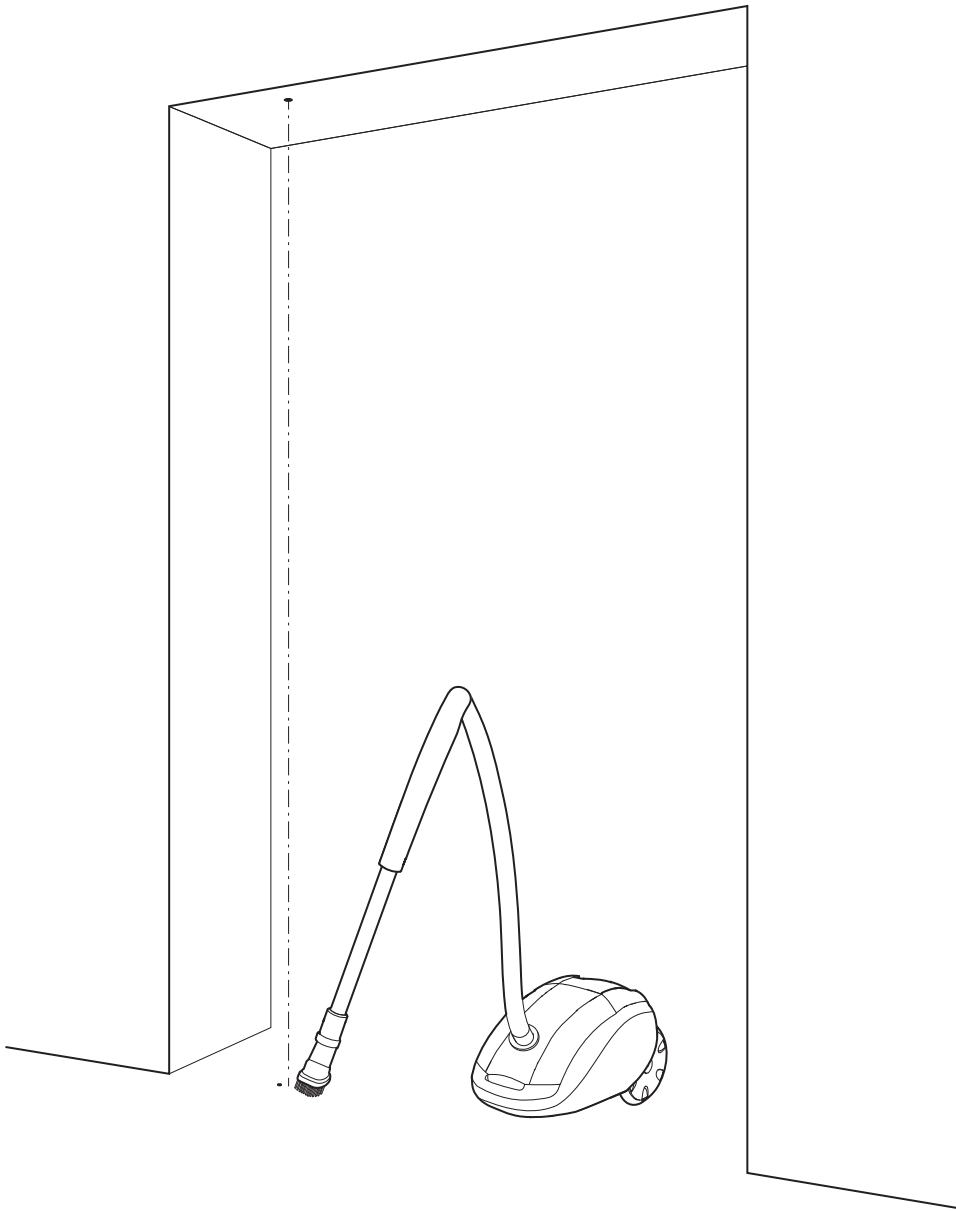



1

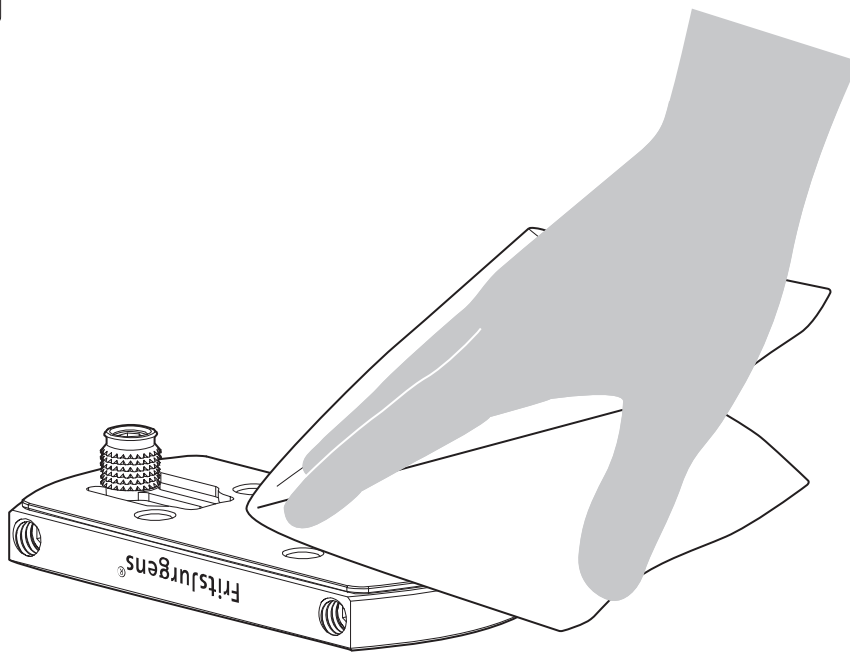

2

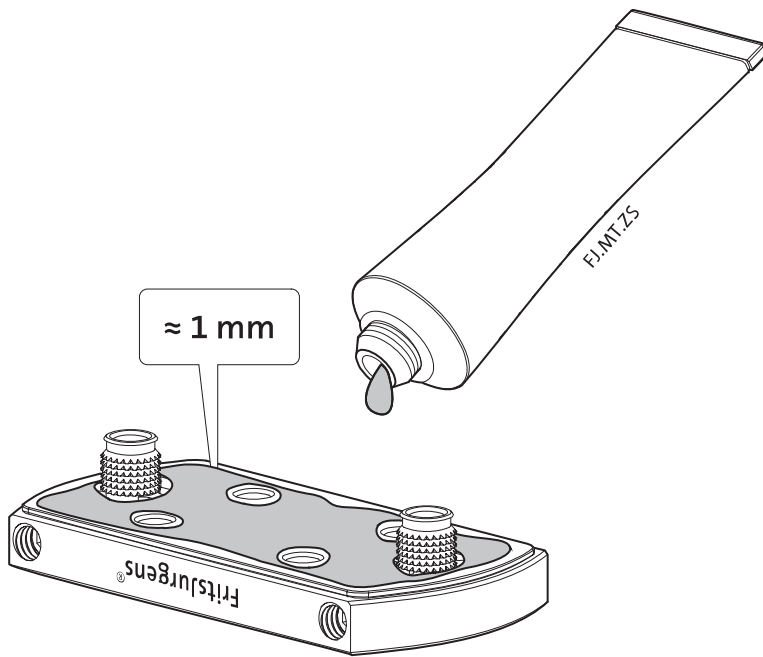

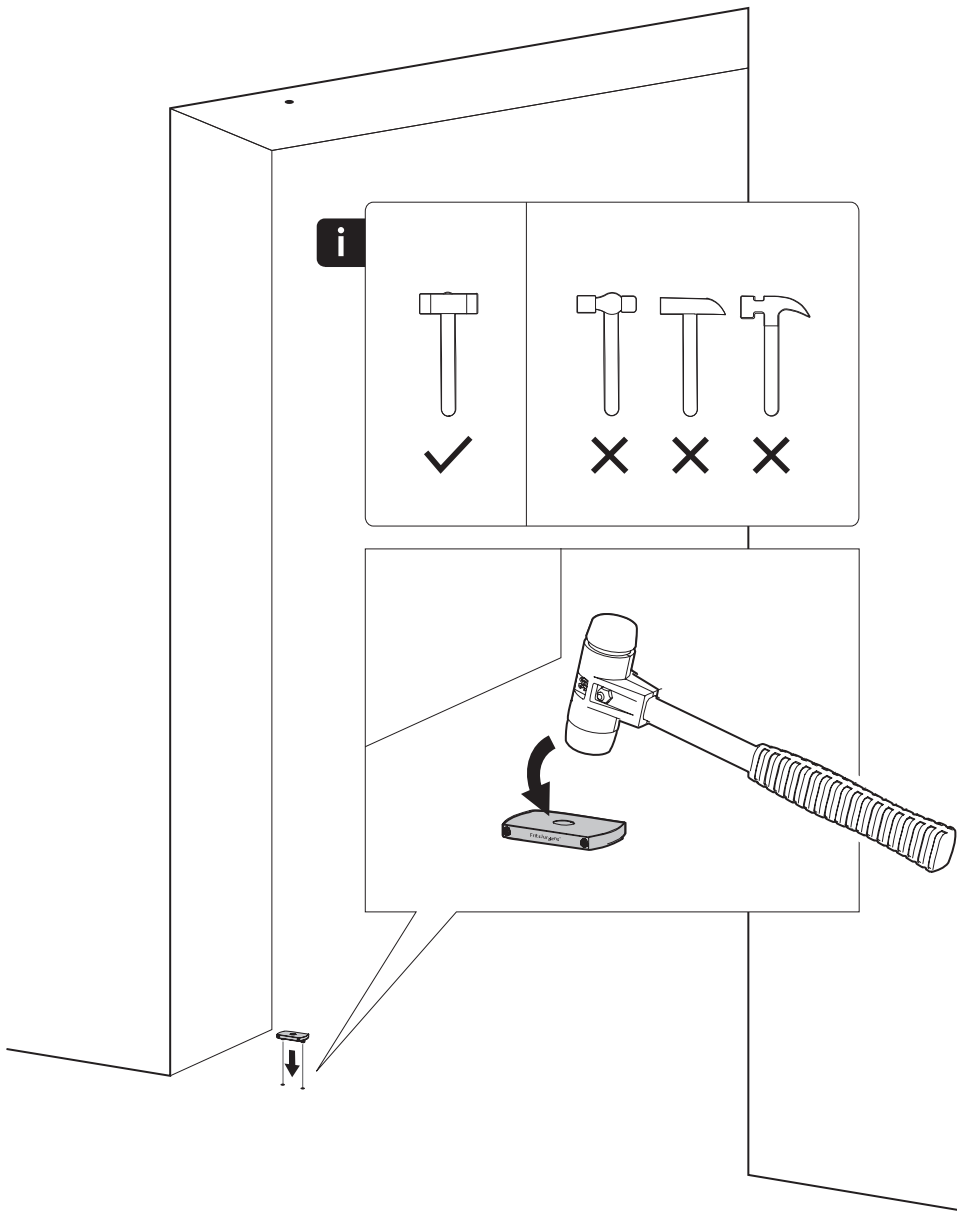

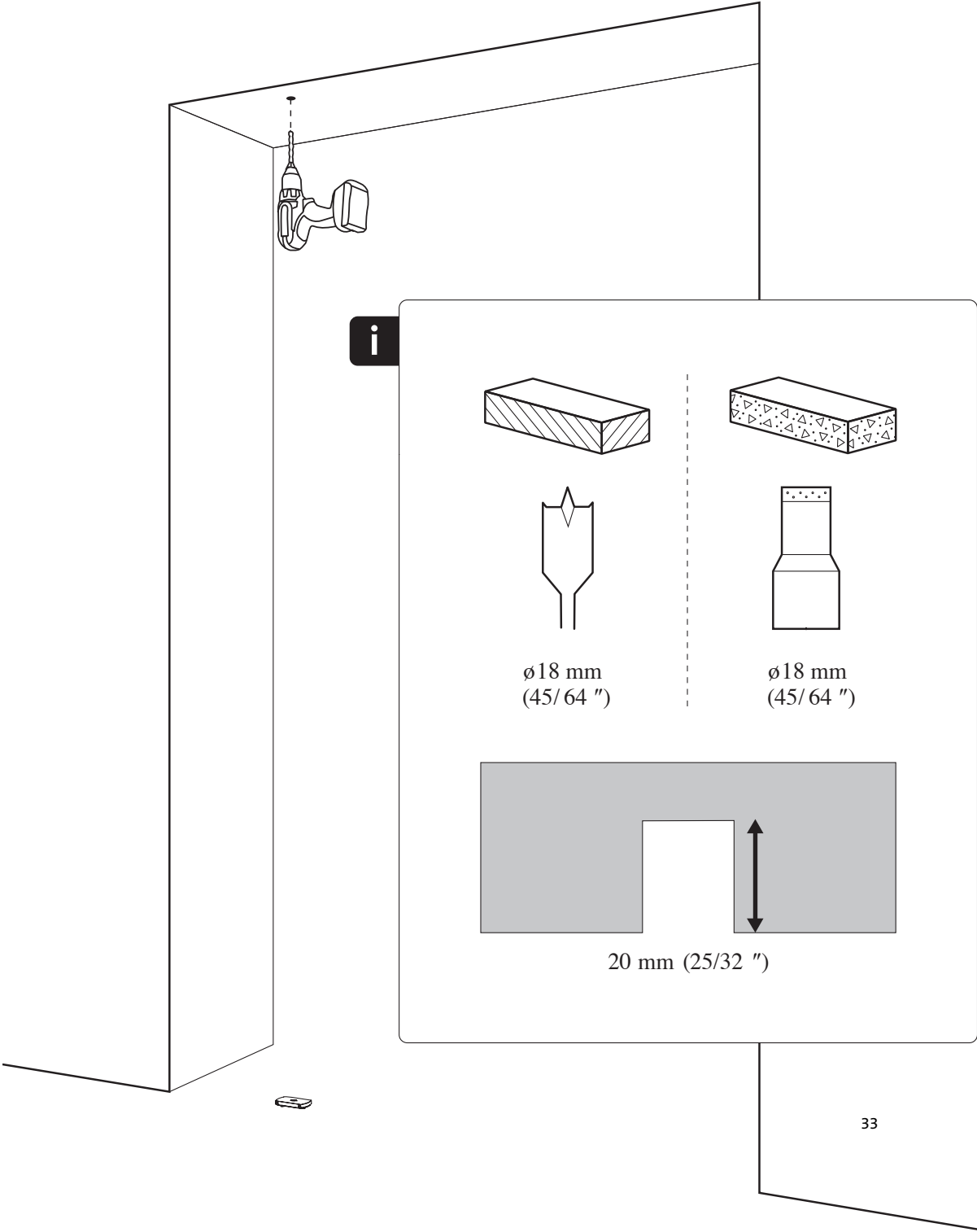
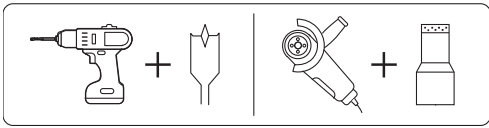



1

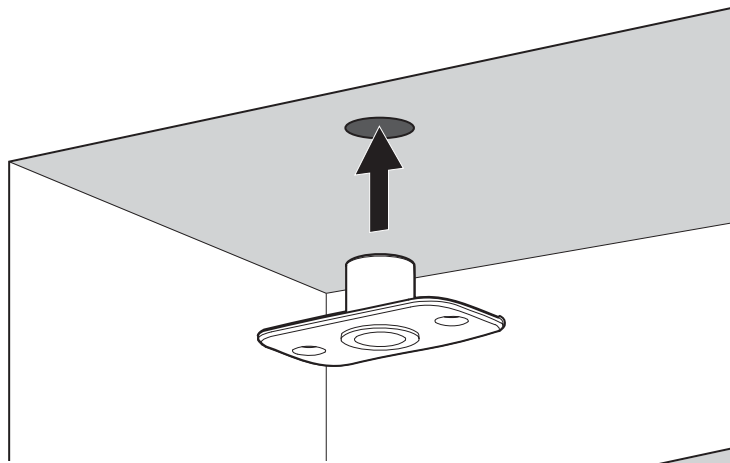

2

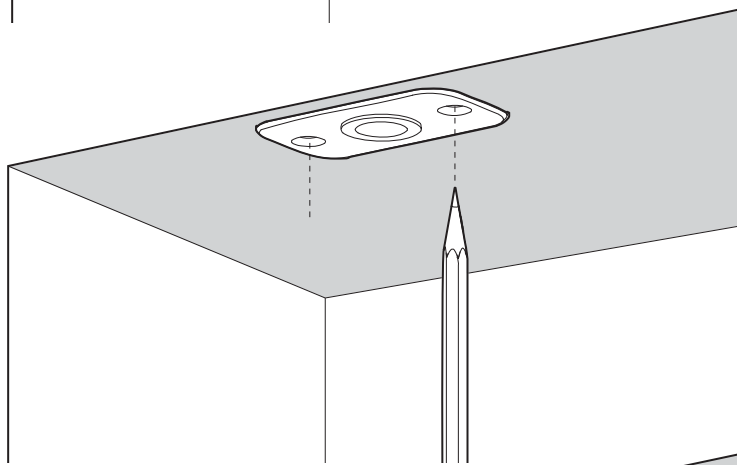

3

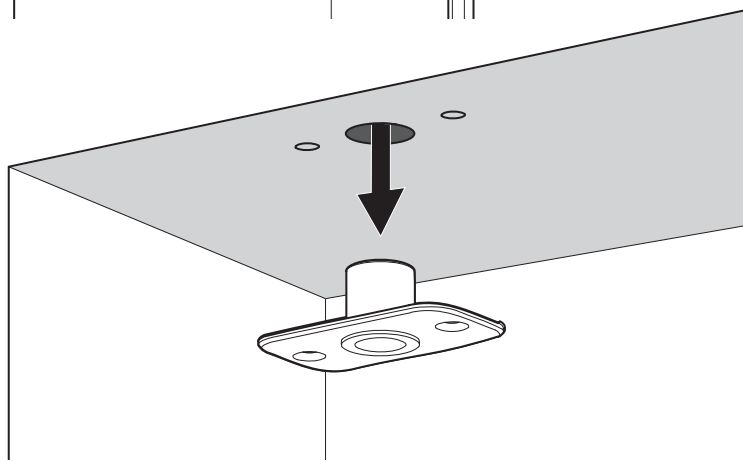



1

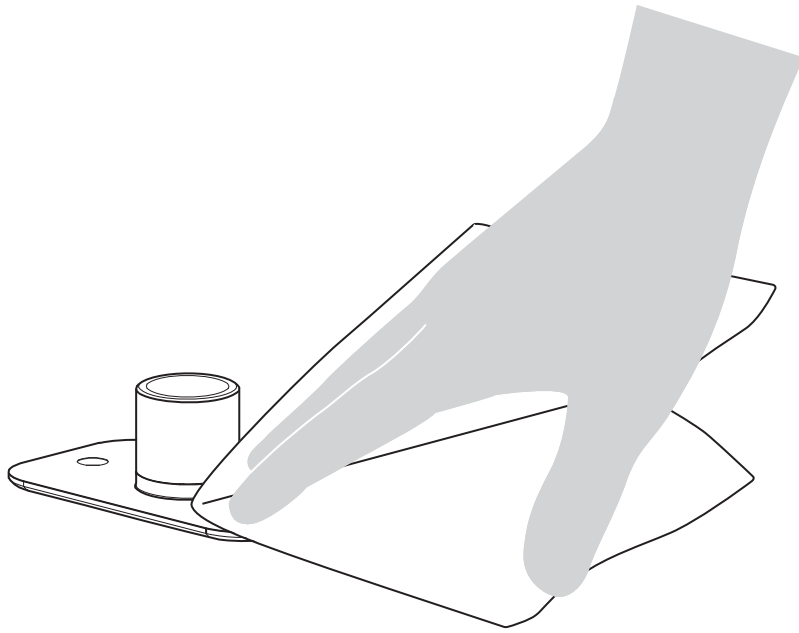

2

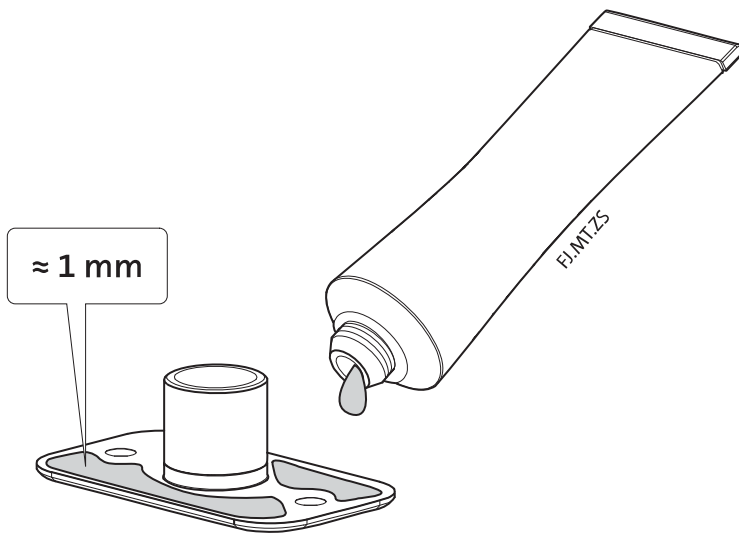

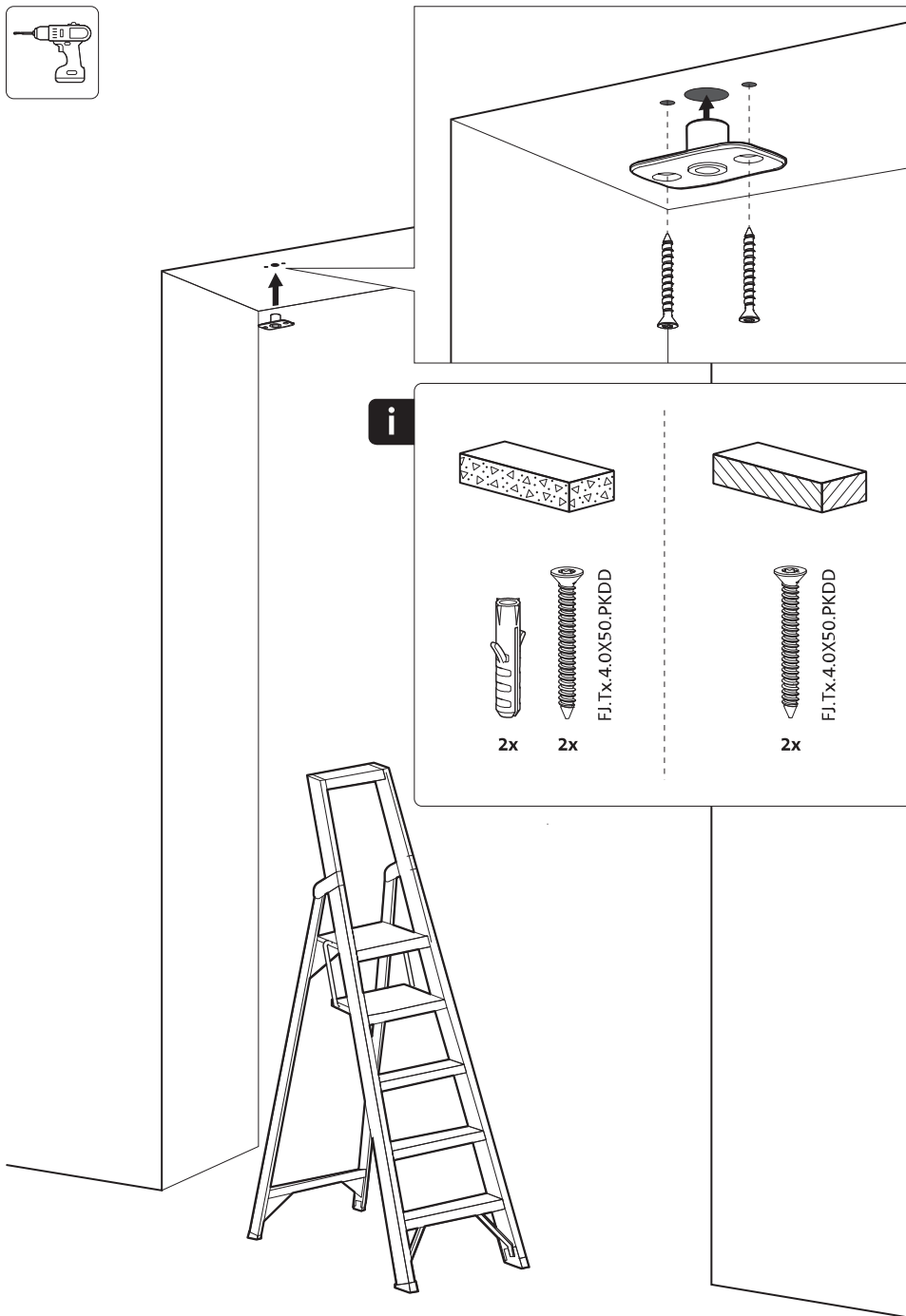

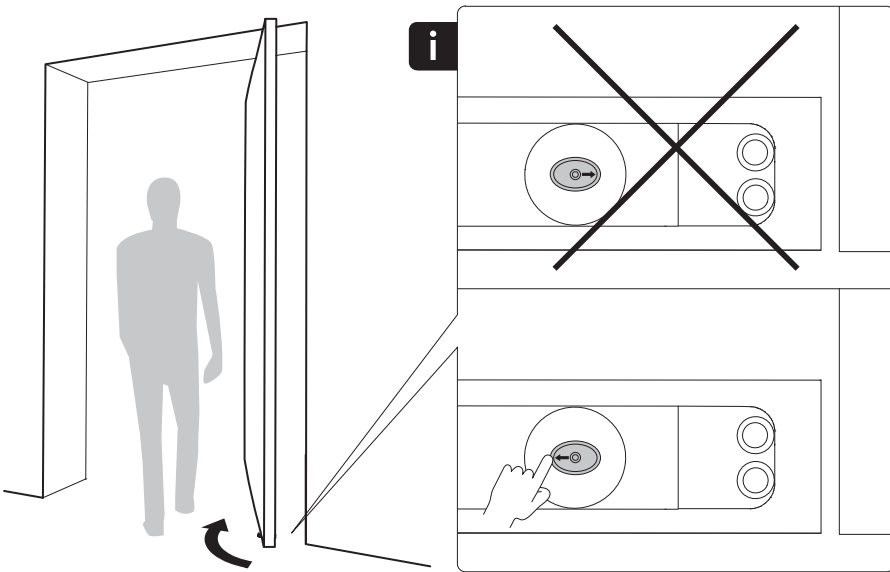
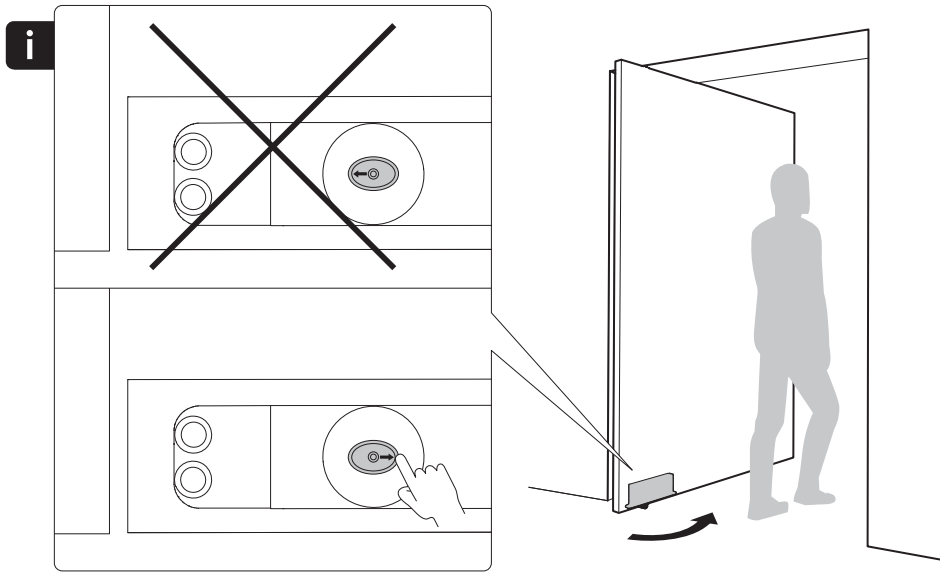

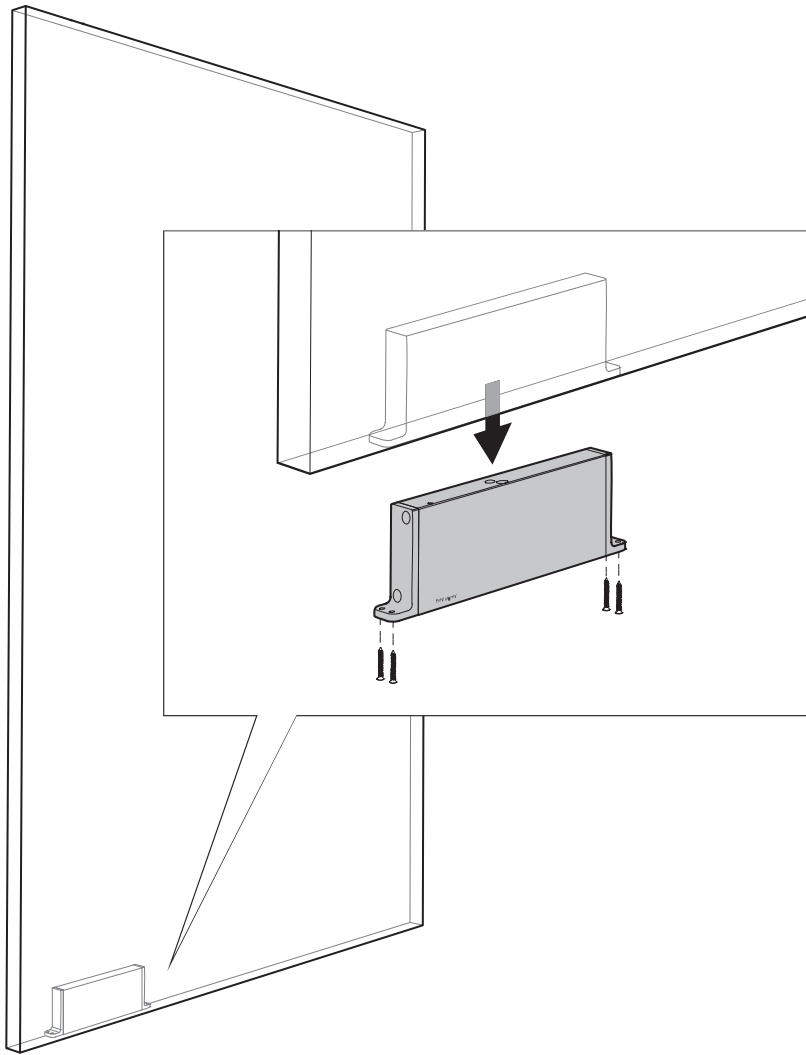

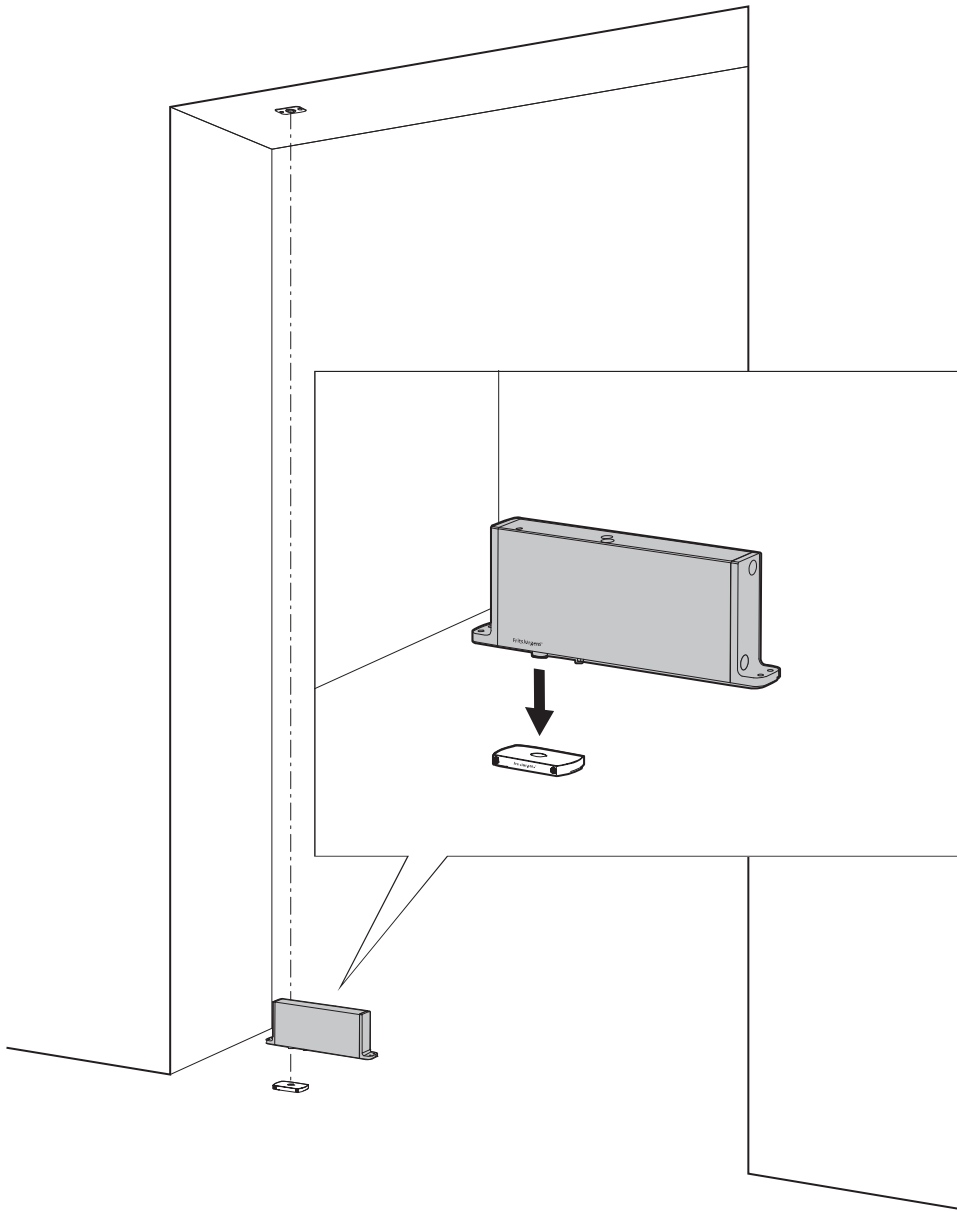

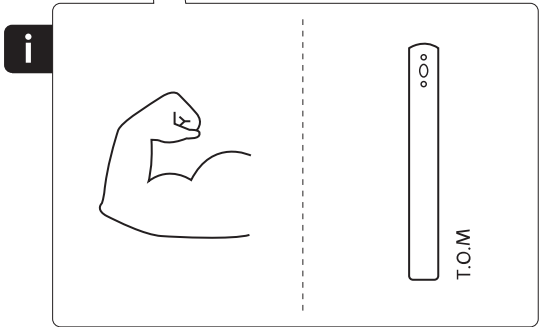
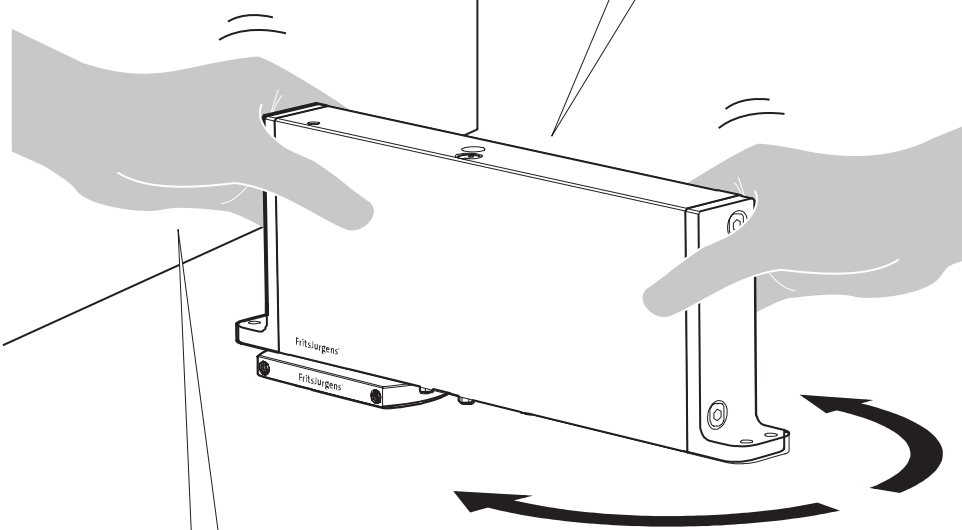
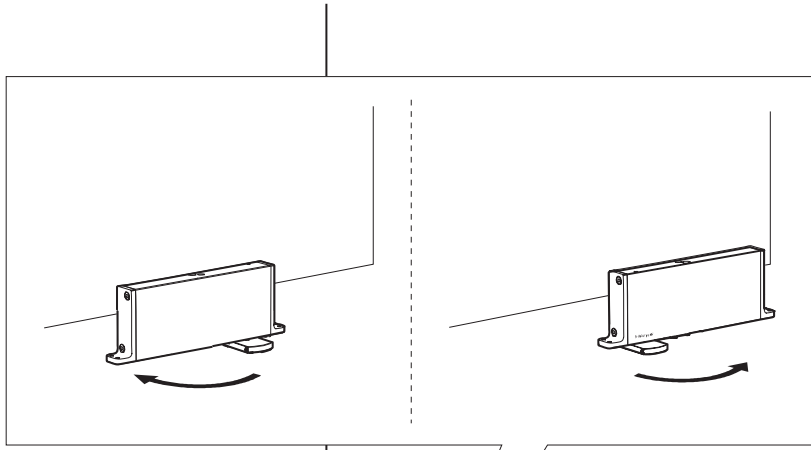

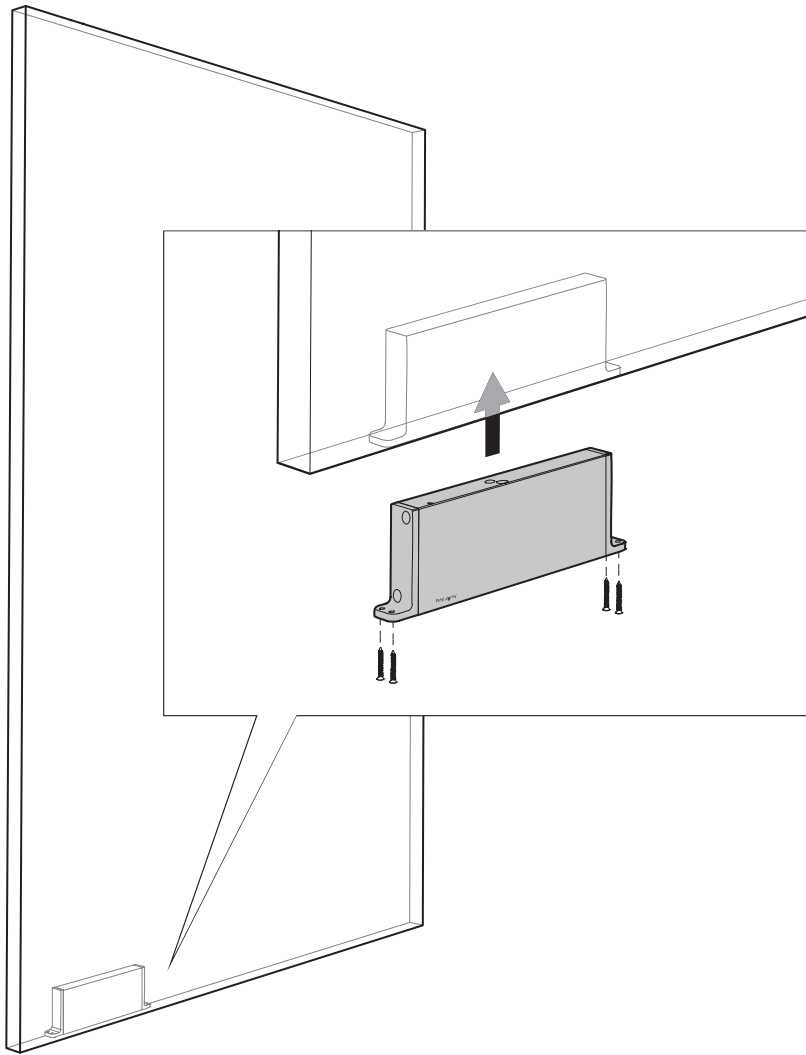

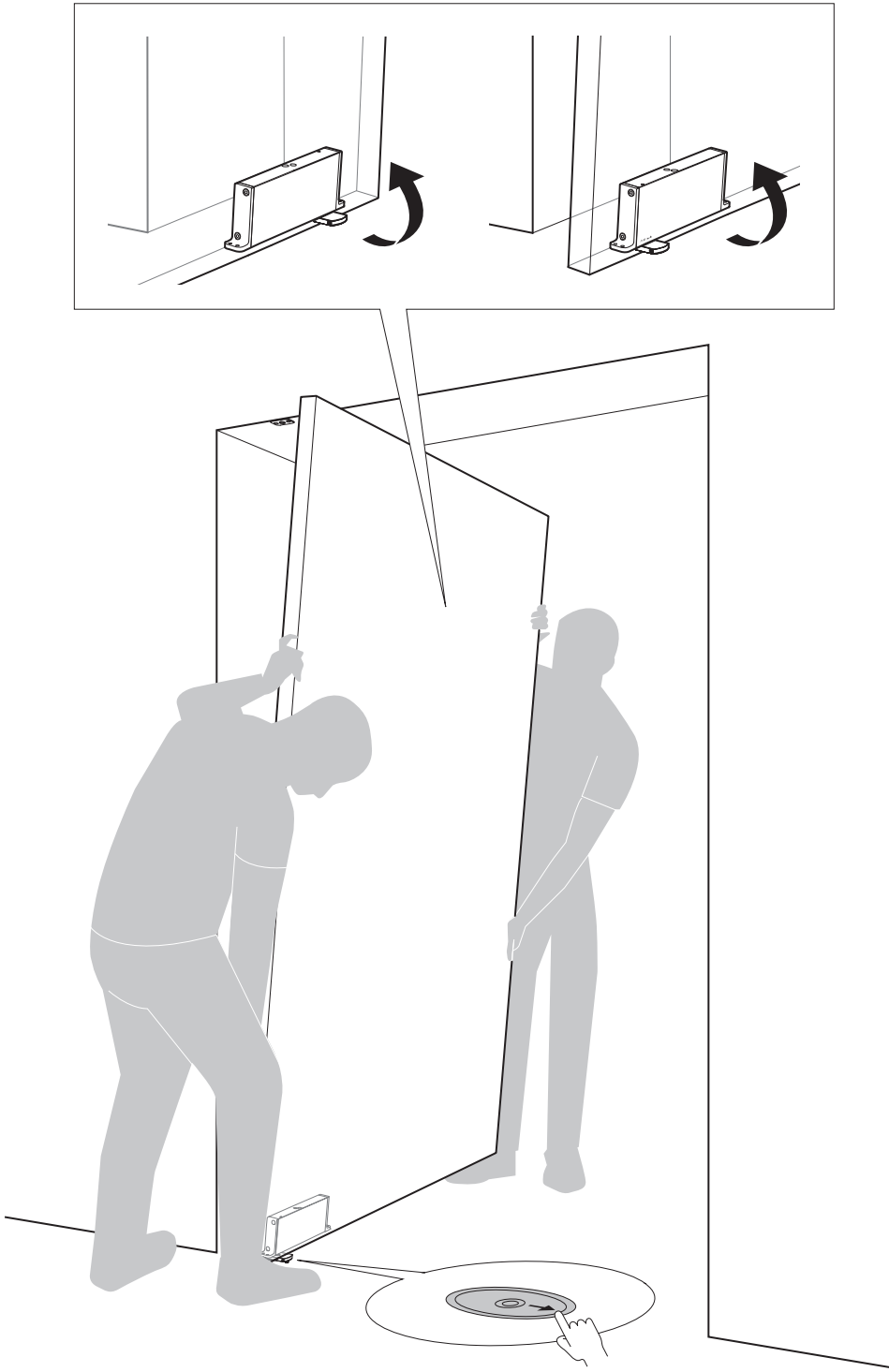

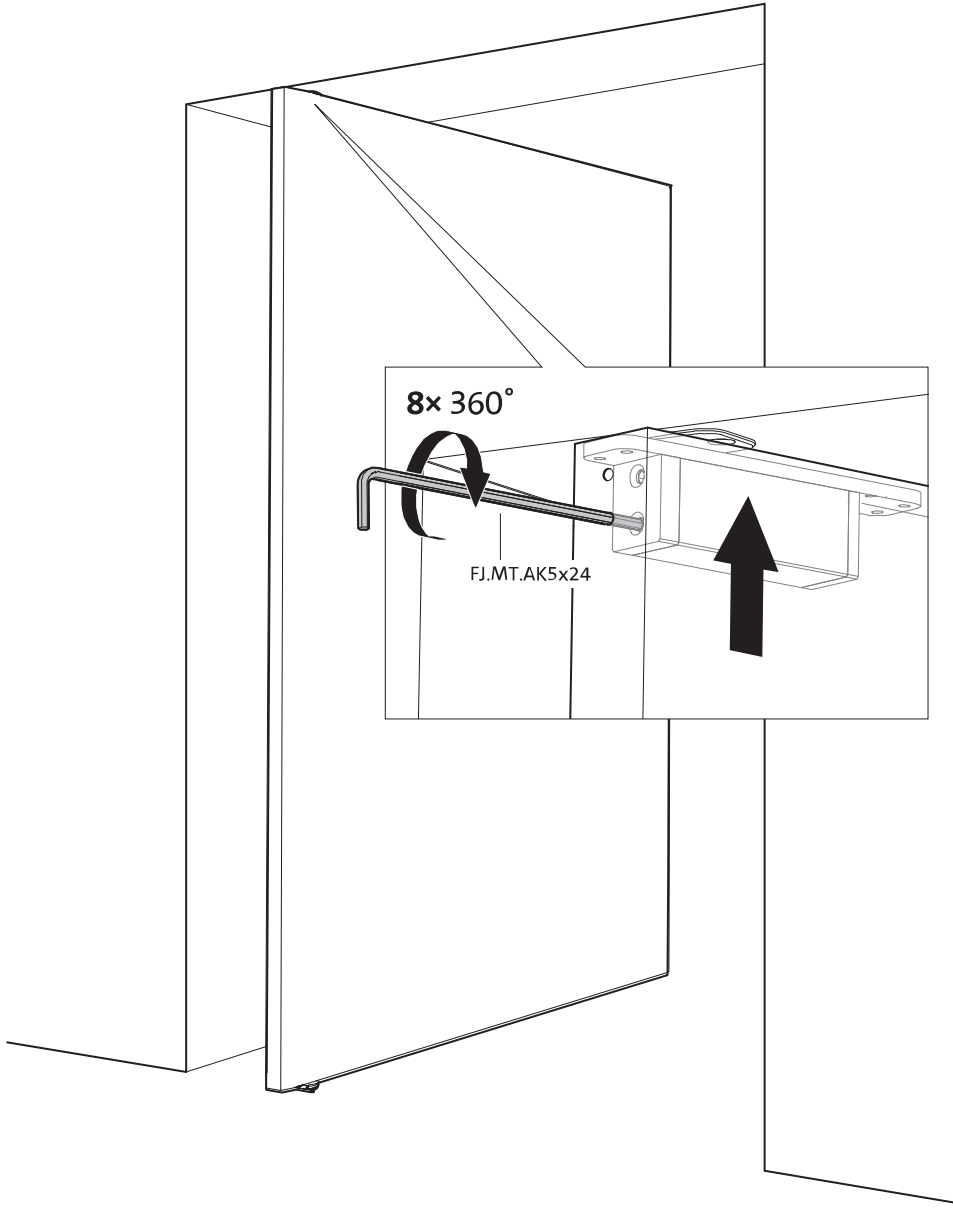
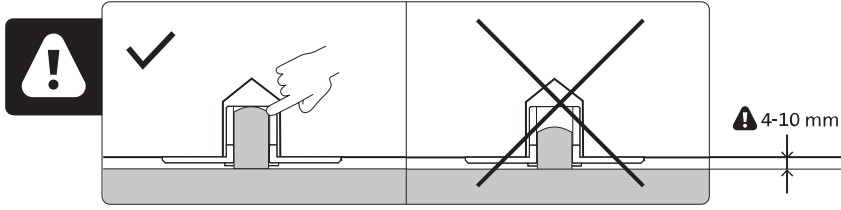

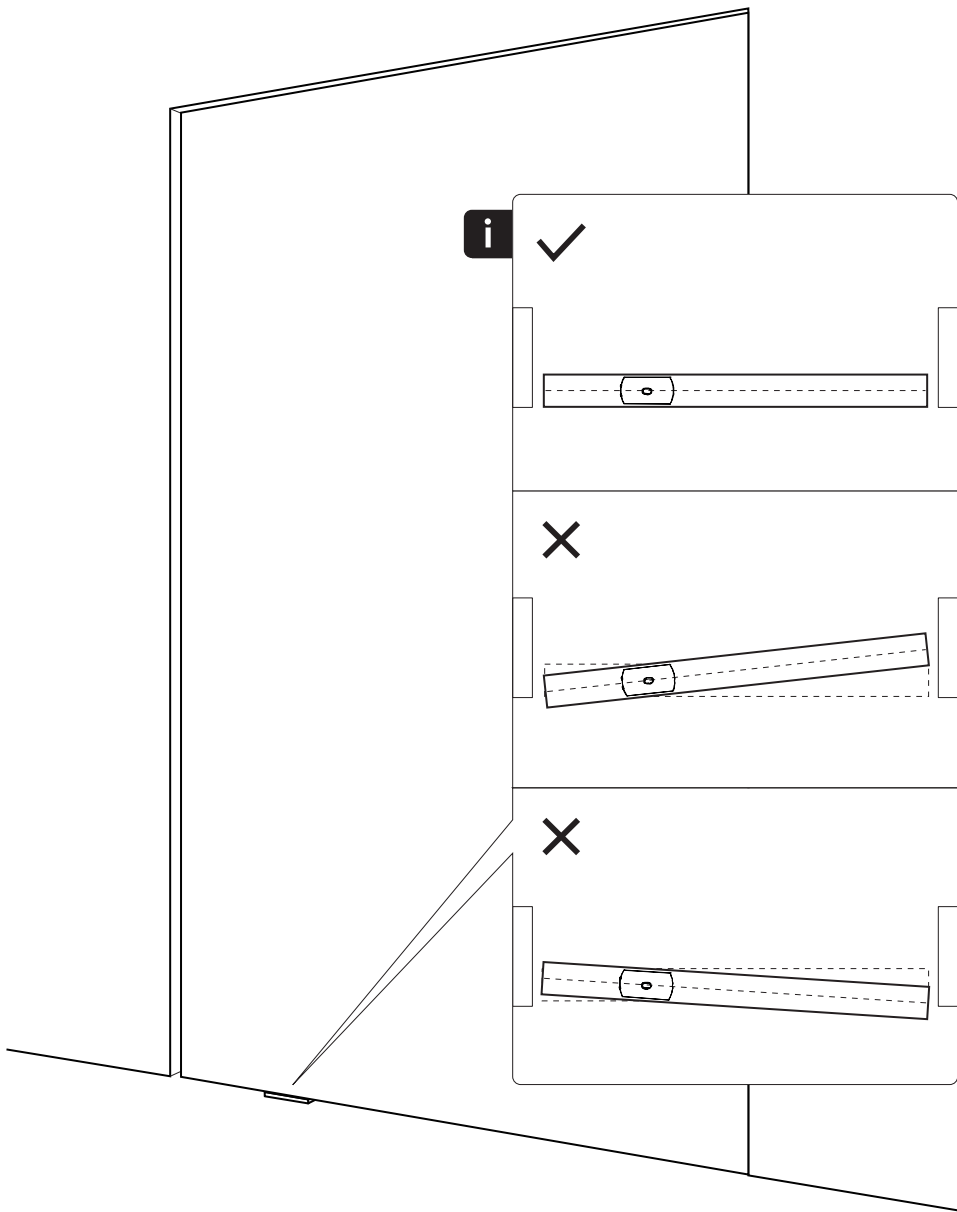

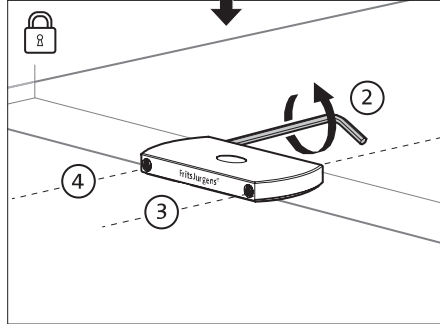
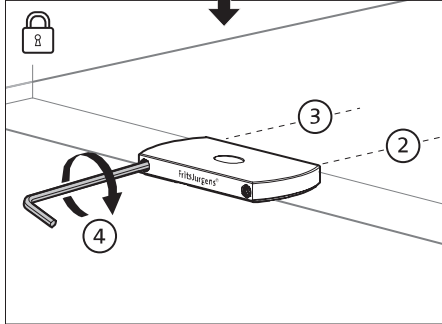
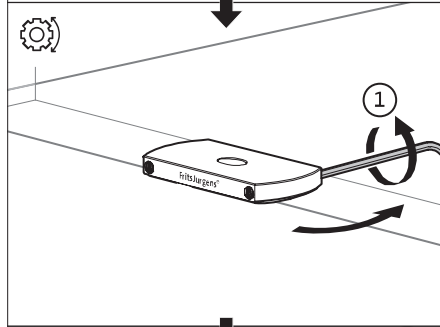
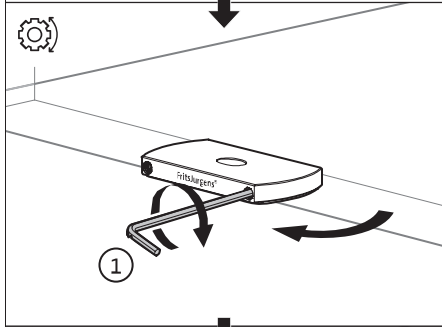
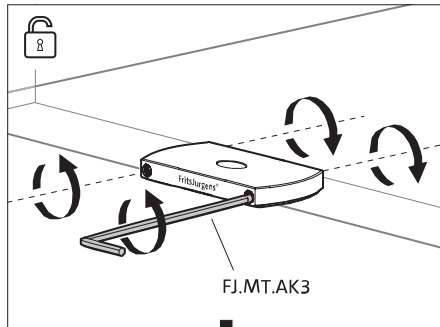
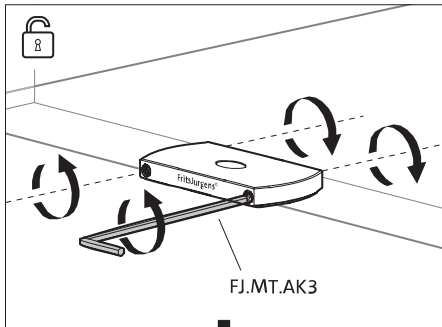
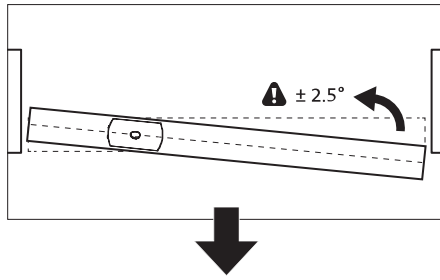
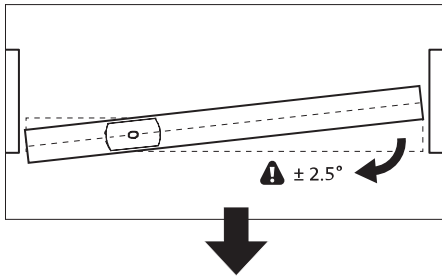

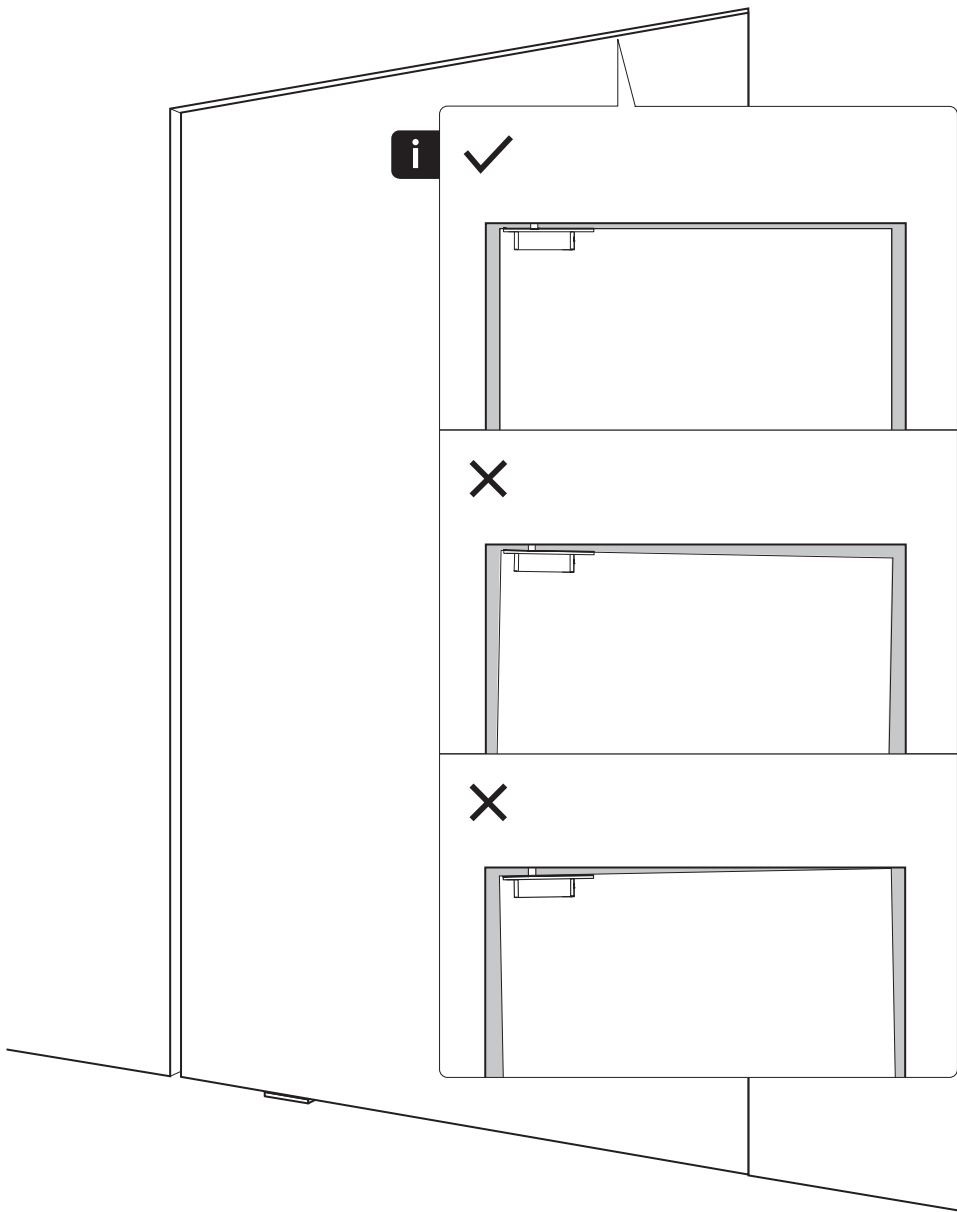

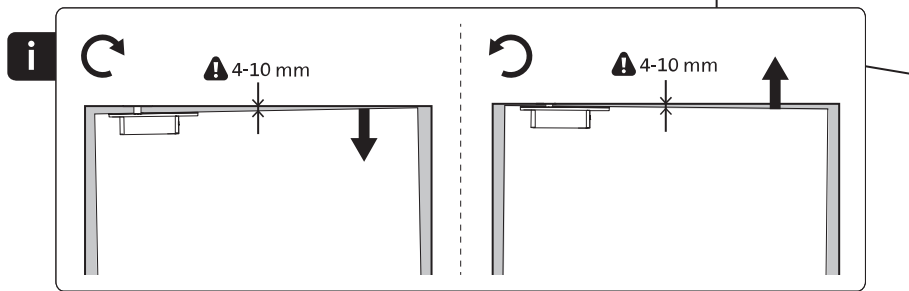
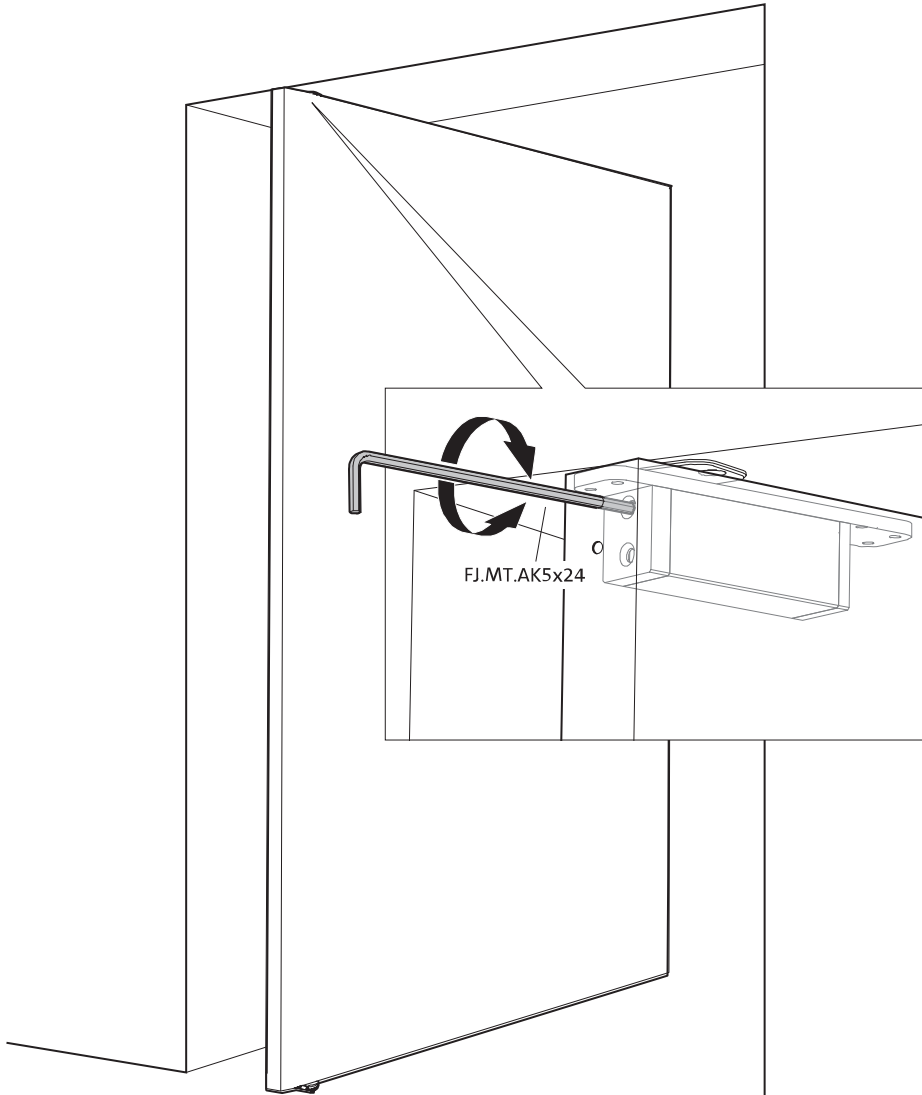

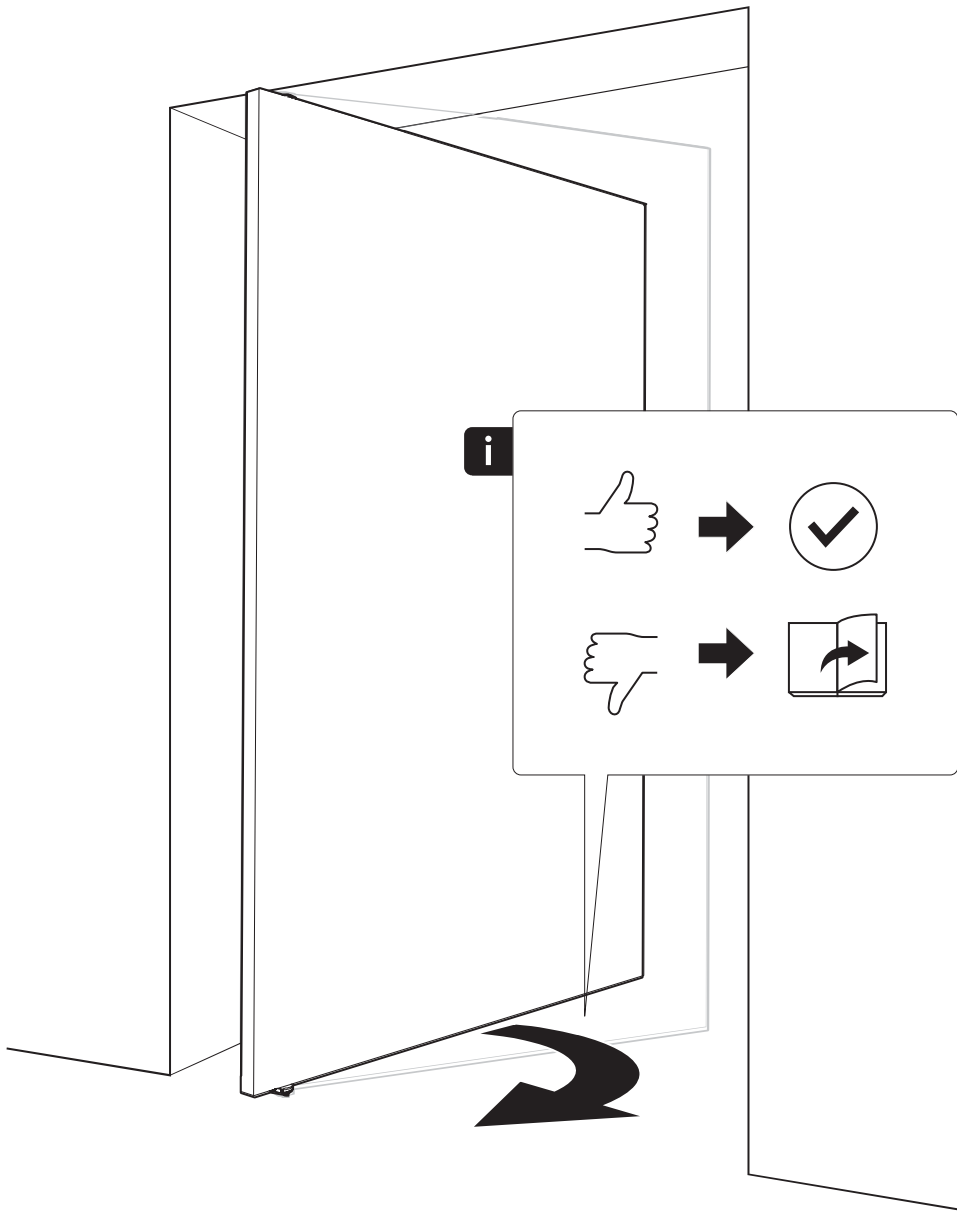



FJ.MT.AC.M+

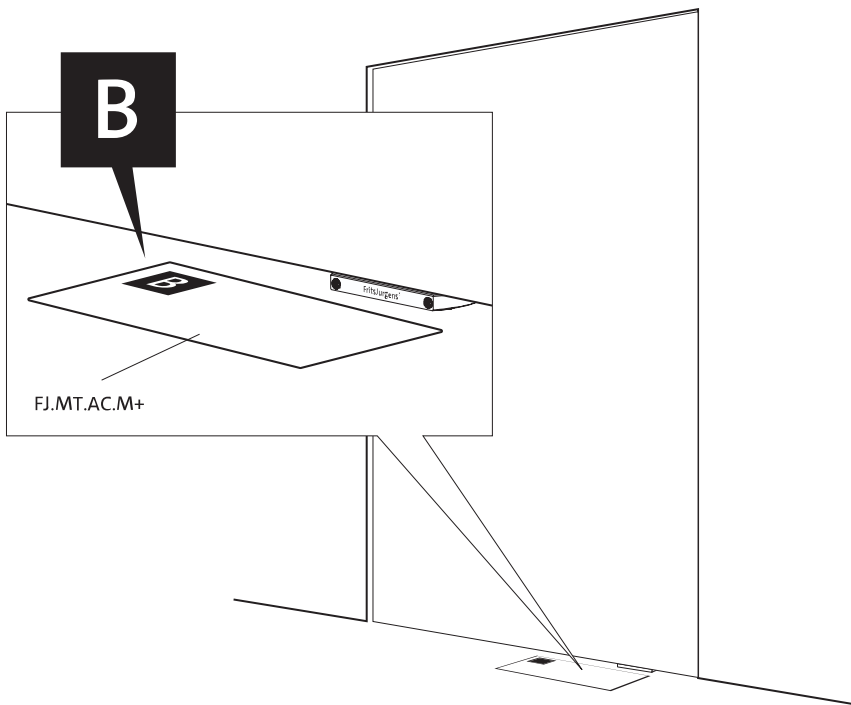
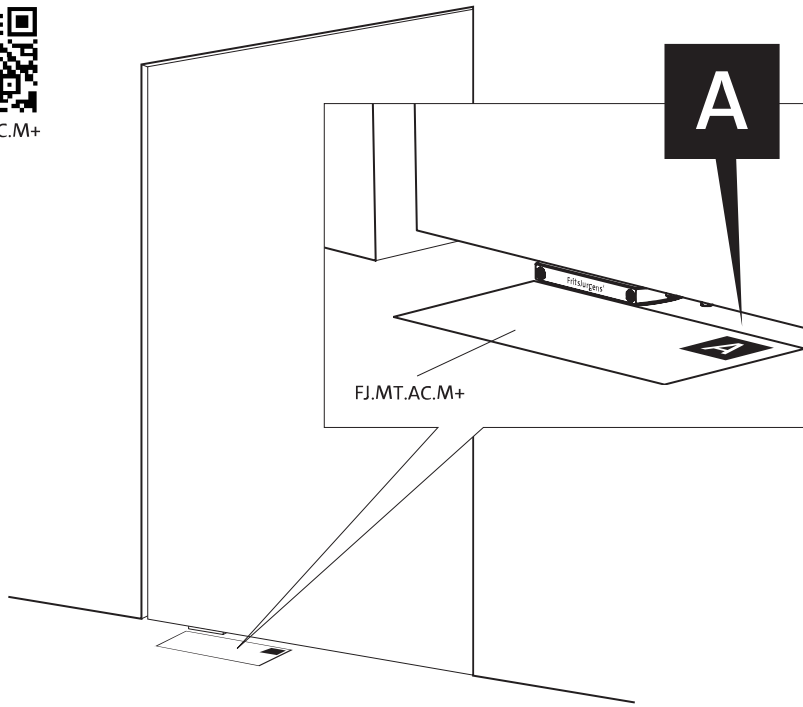

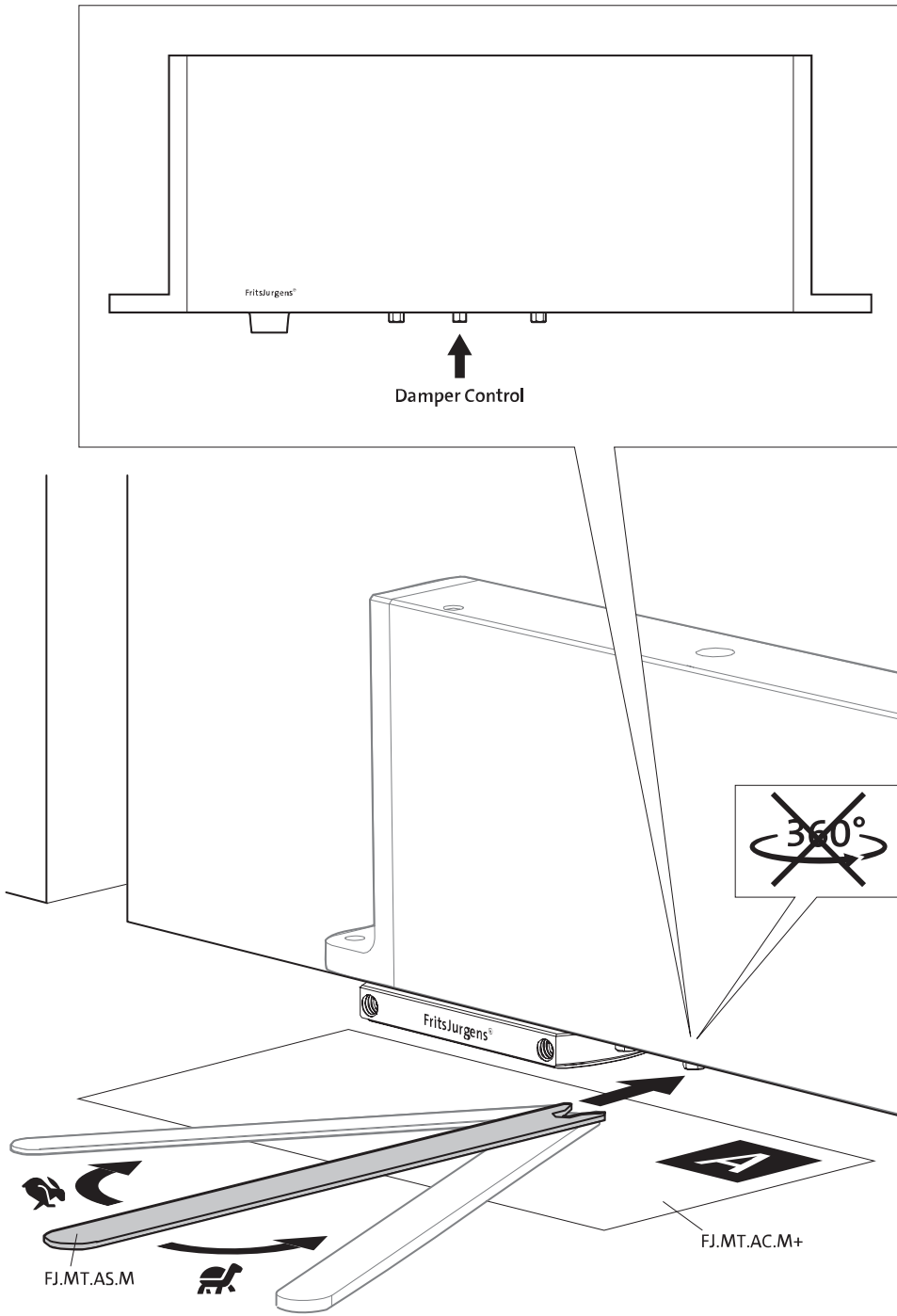

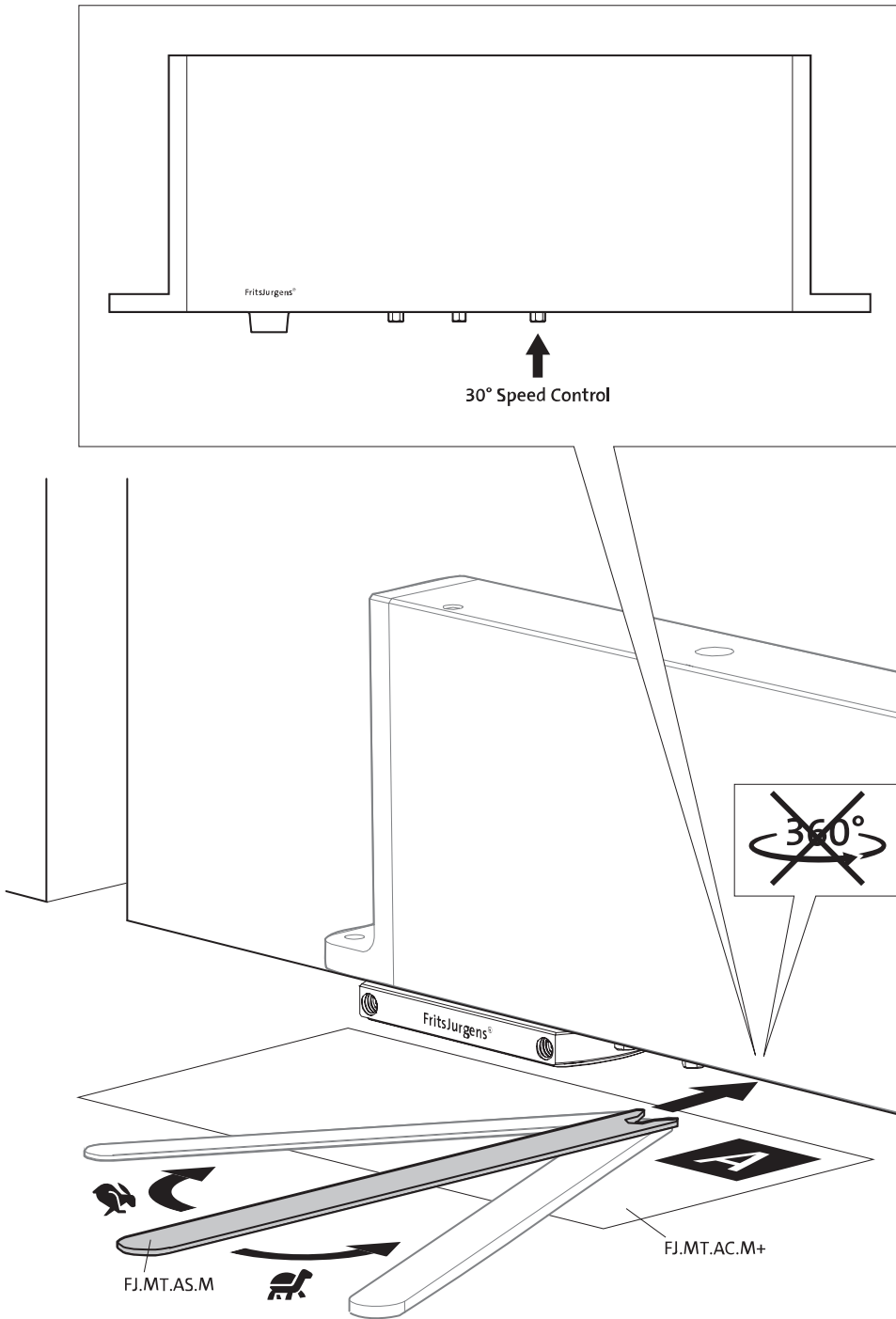

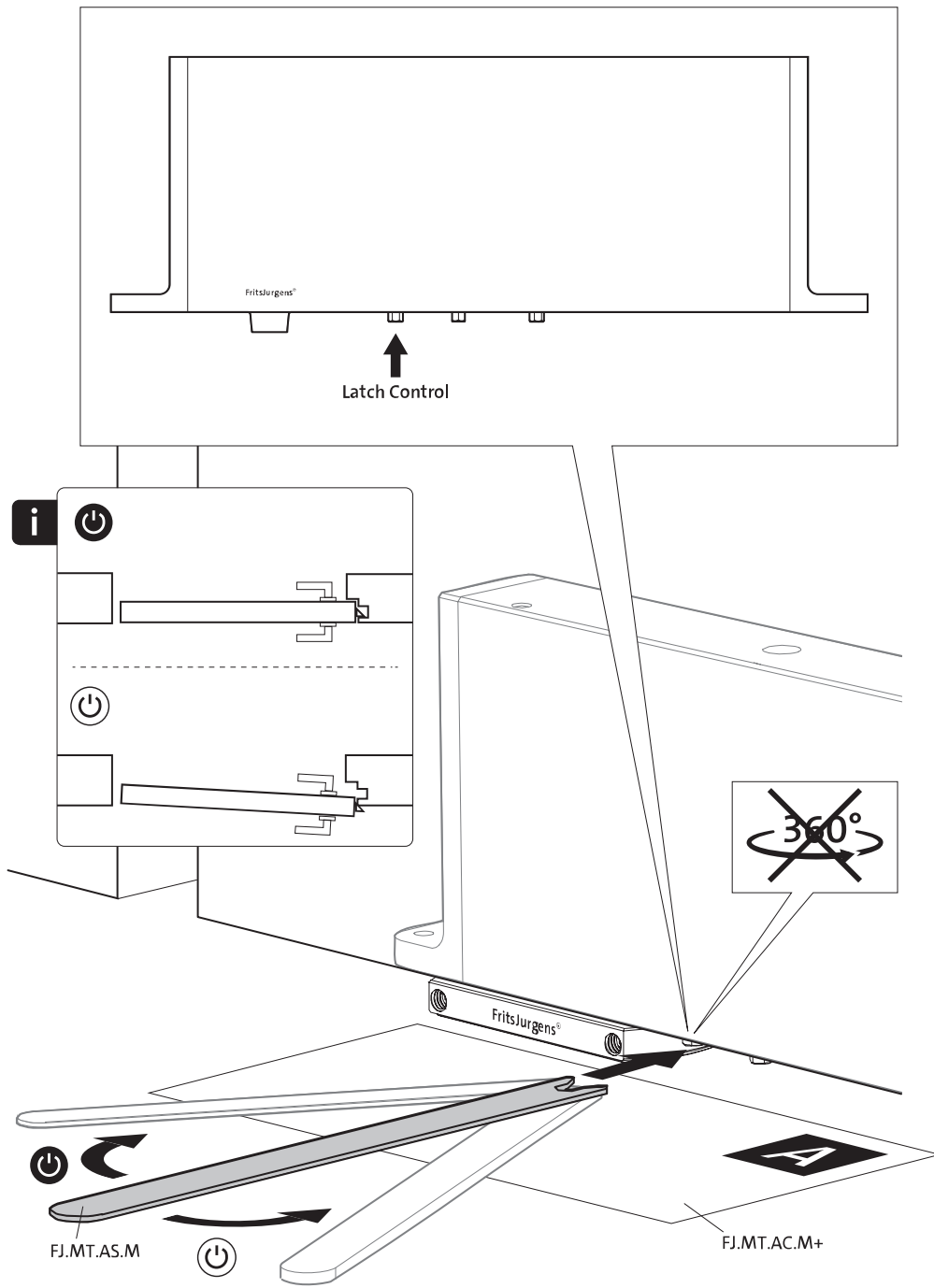

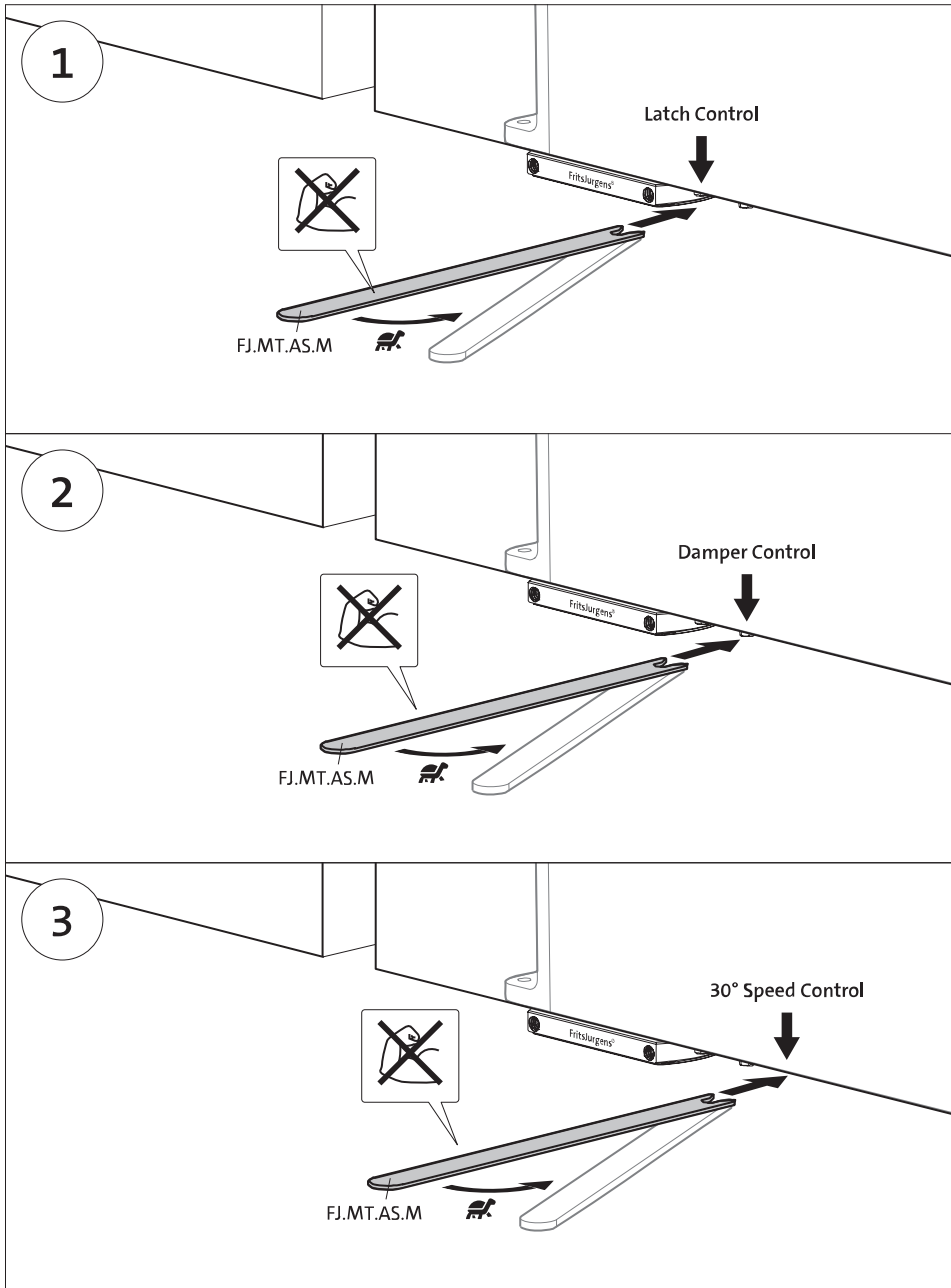

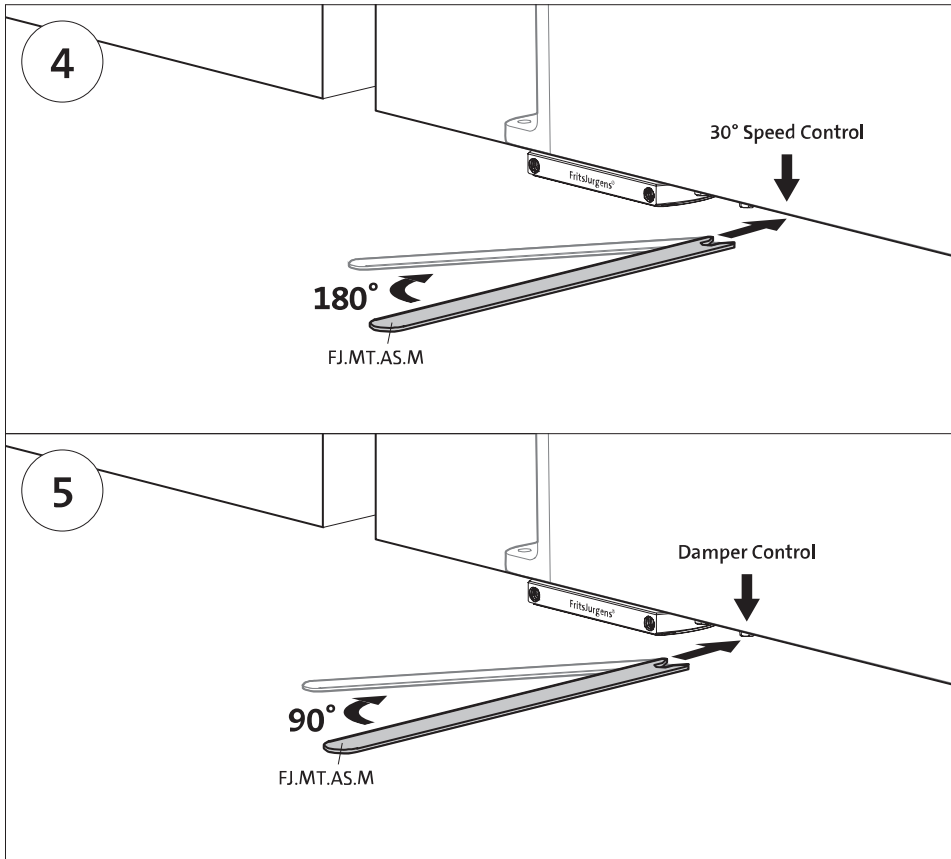

Disassembly instructions

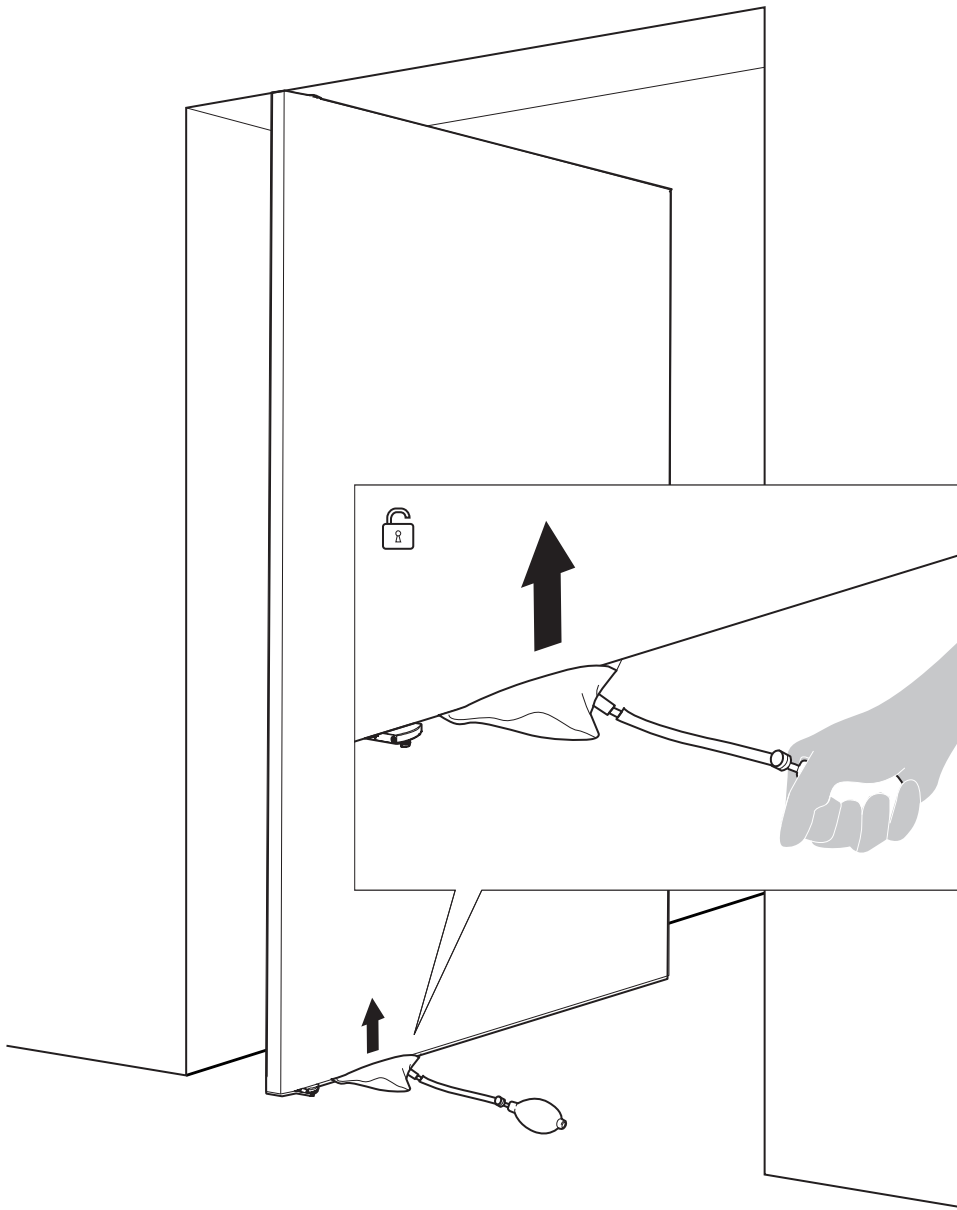

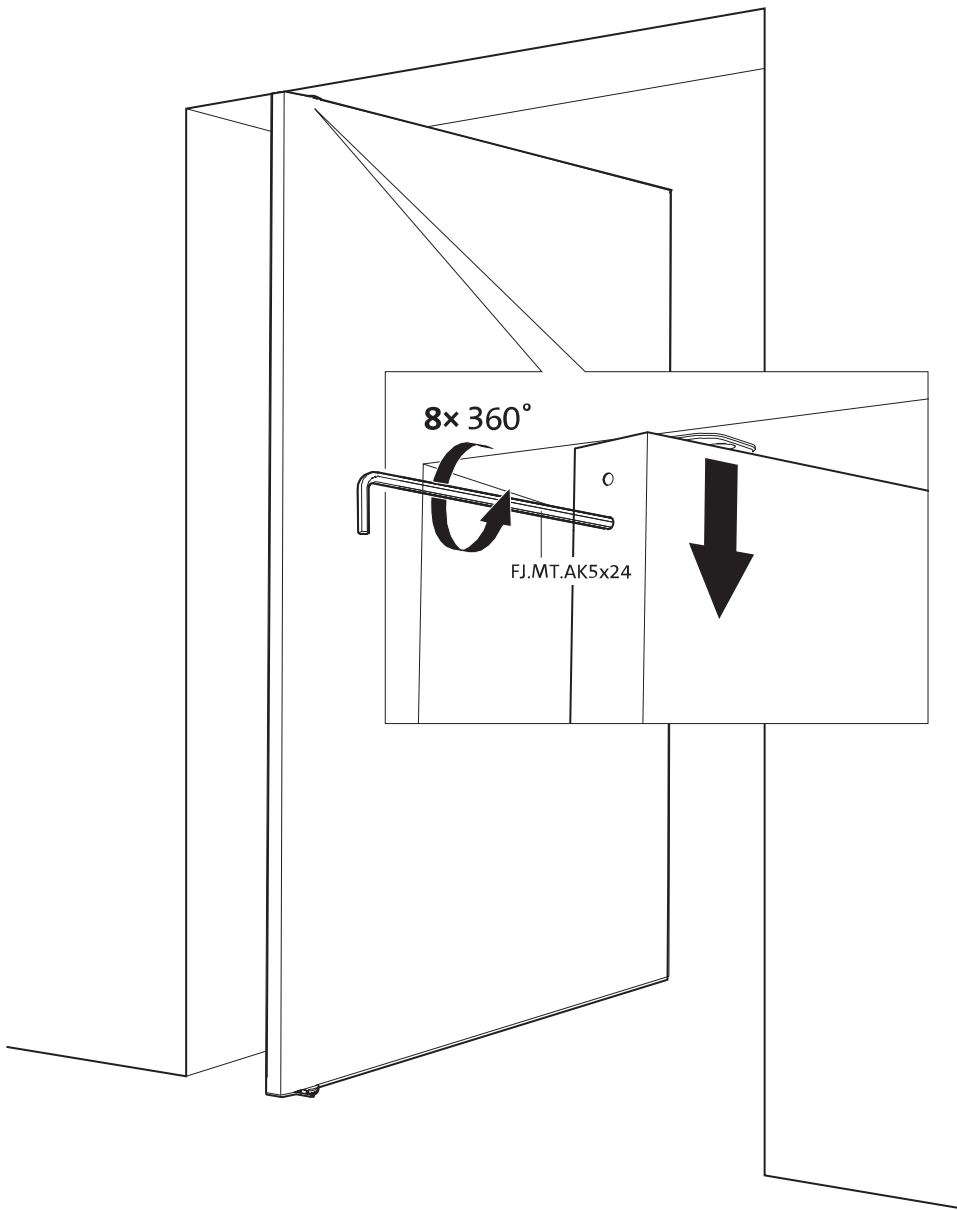

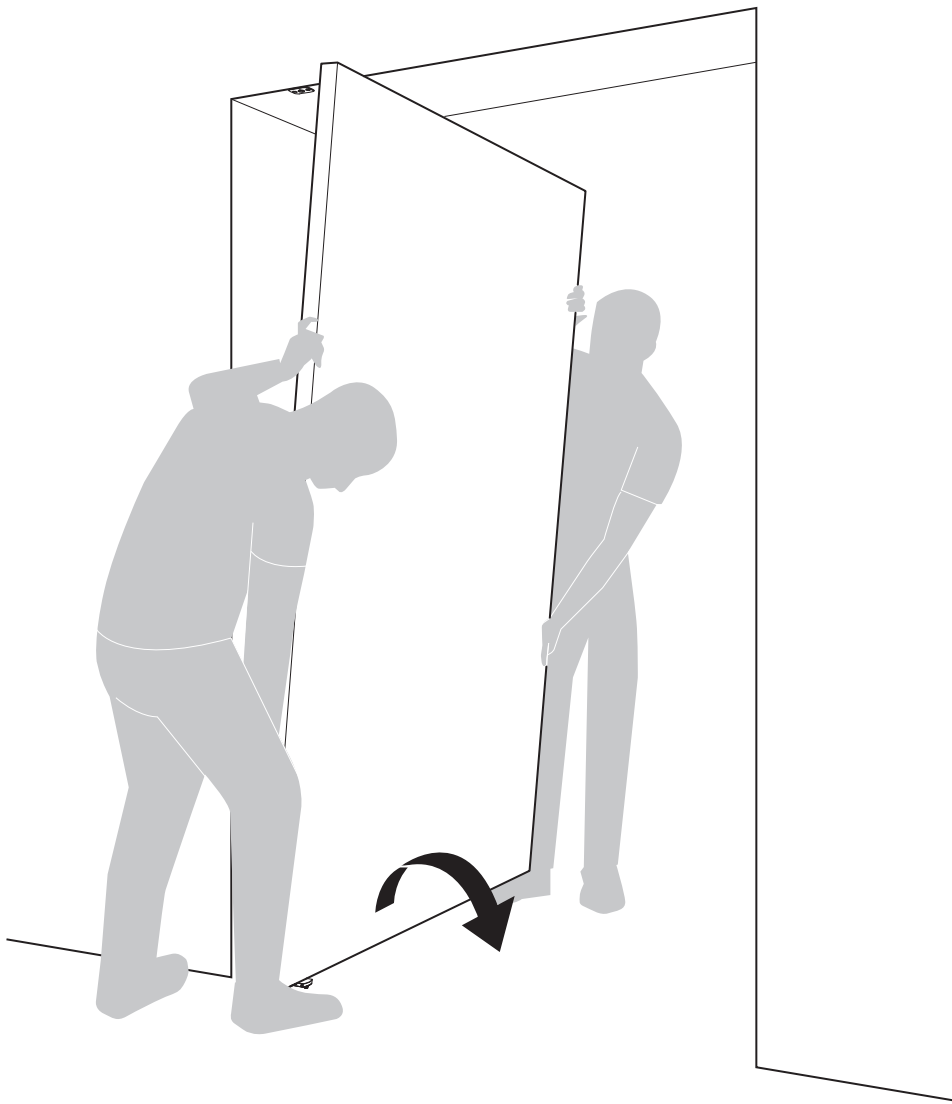

FritsJurgens International

A. Einsteinlaan 1
The Netherlands
9615 TE Kolham
+31 598 343 410
info@fritsjurgens.com

FritsJurgens Dubai Branch

DLC-OP-A2-4-0029
Dubai South
Dubai
United Arab Emirates
+971 4 820 8106
+971 58 137 2611
dubai@fritsjurgens.com
fritsjurgens.com

Copyright © FritsJurgens®
BPM+.70.G.X.XX



8 719325 750645