

System One

Milling and mounting manual

FritsJurgens Set - 70 mm Class G - invisible

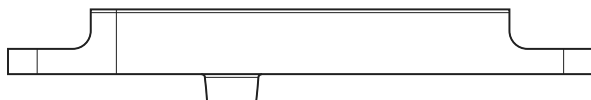

FritsJurgens®

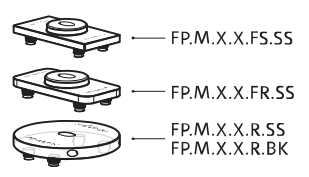
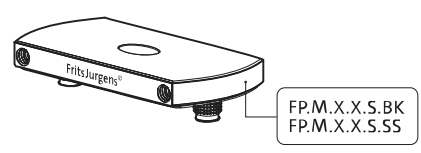
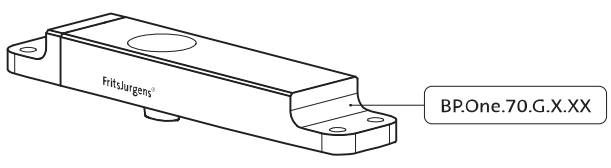
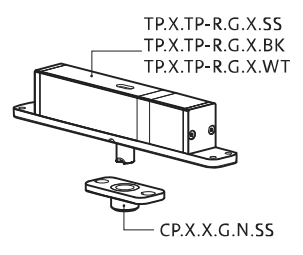
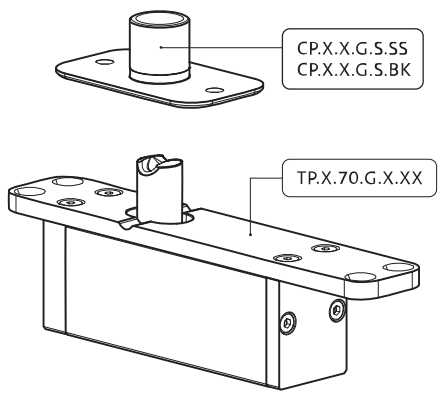

Milling instructions

BP.One.70.G.X.XX

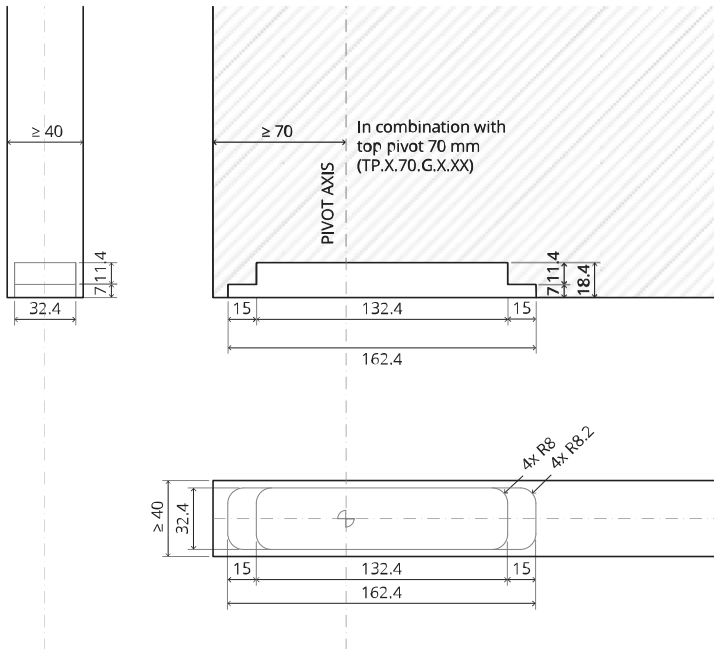

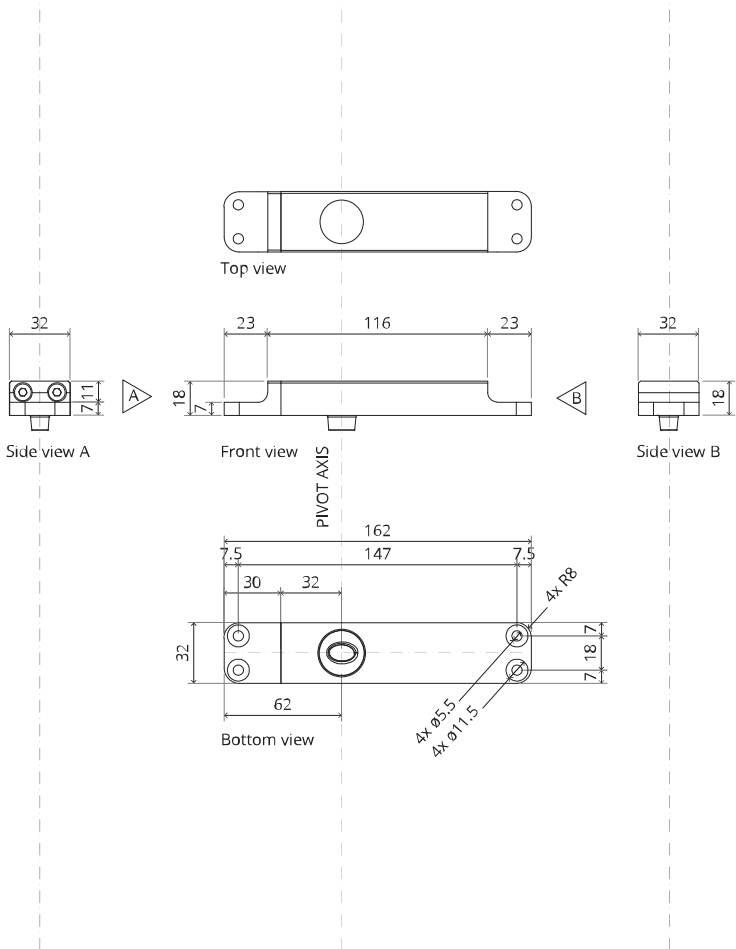

TP.X.70.G.X.XX

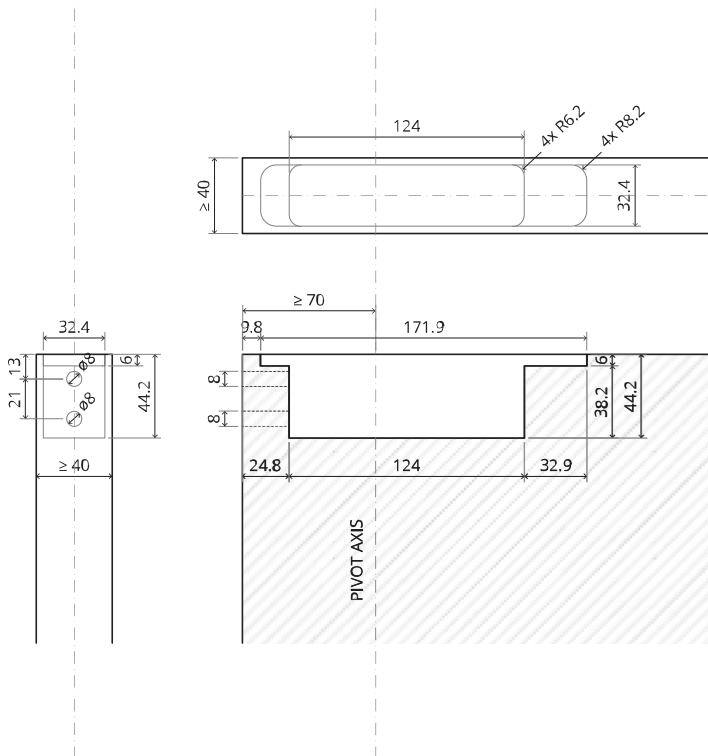

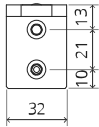

Side view A with pin turned in

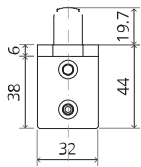

Side view A with pin turned out

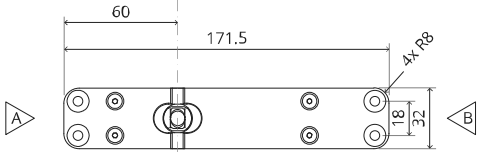

Top view

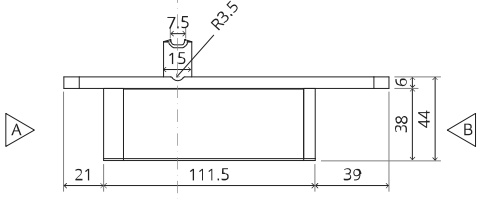

Front view

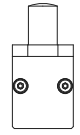

Side view B

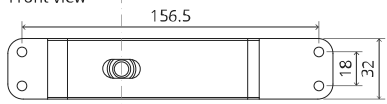

Bottom view

TP.X.TP-R.G.X.

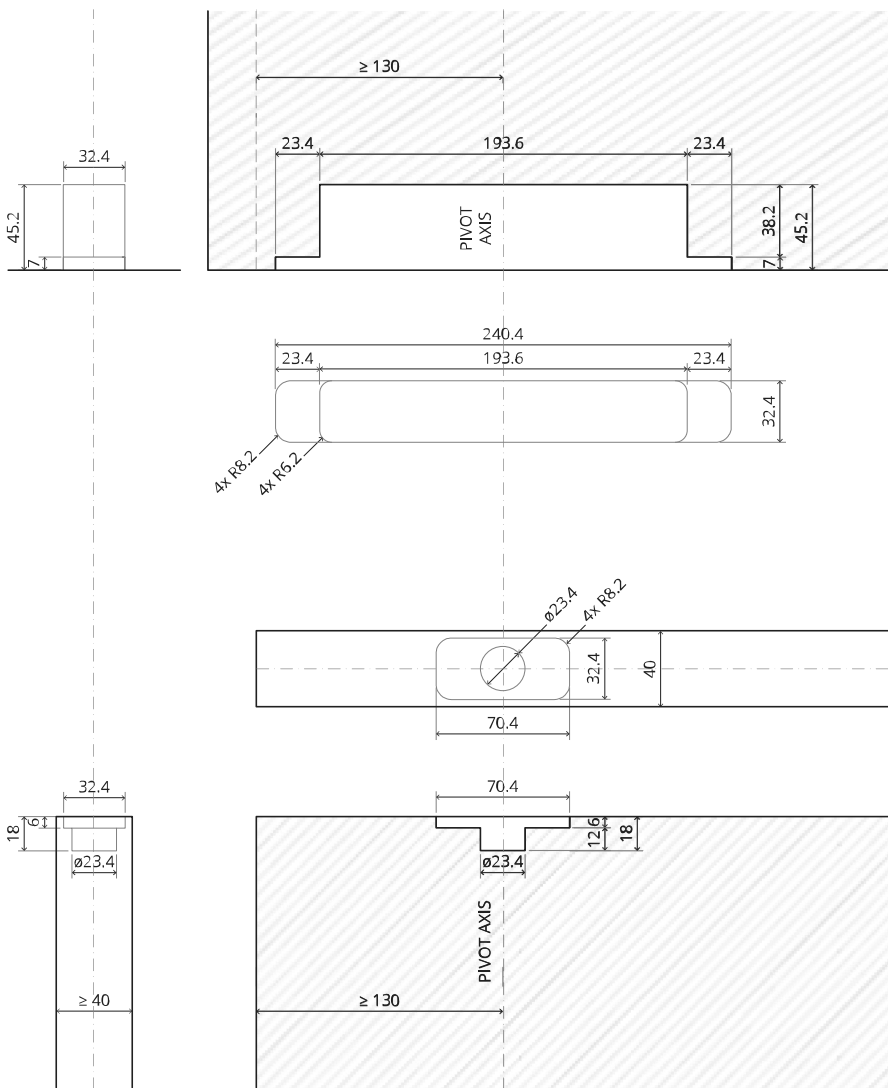

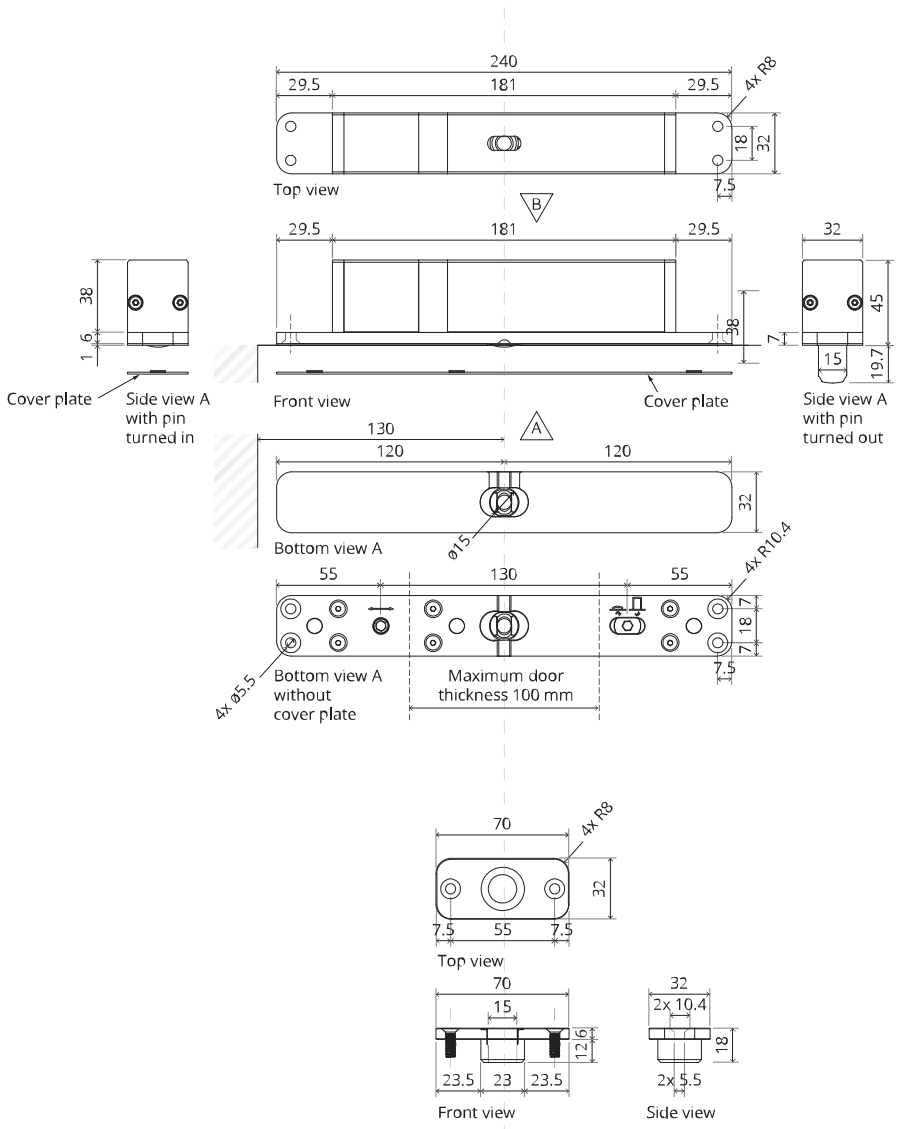

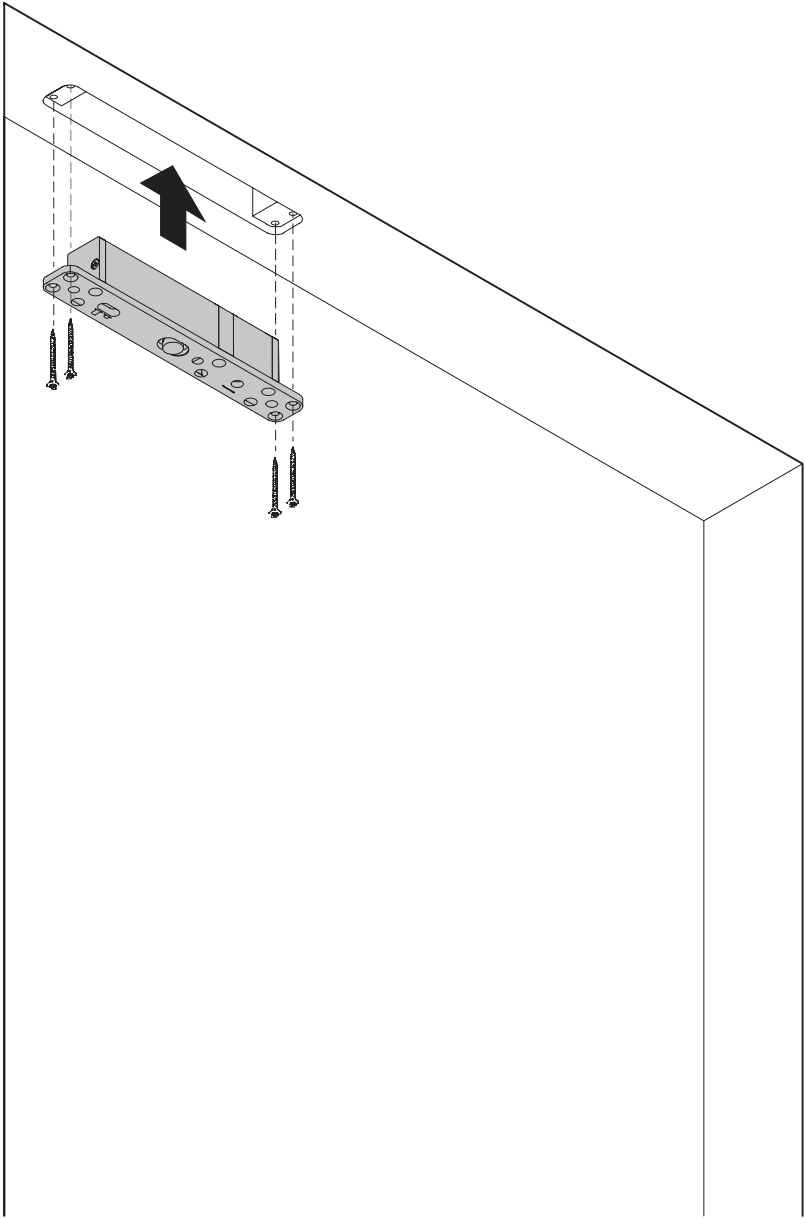

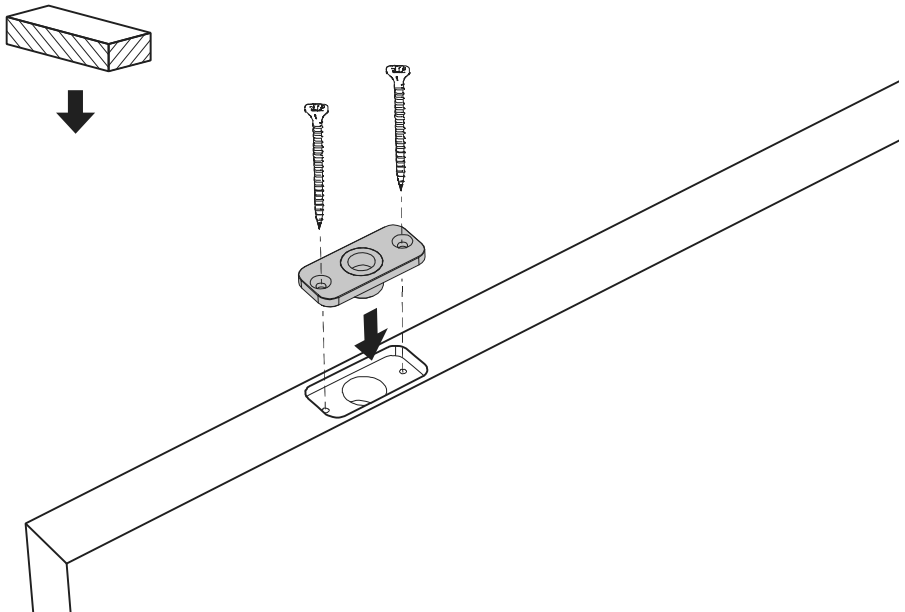
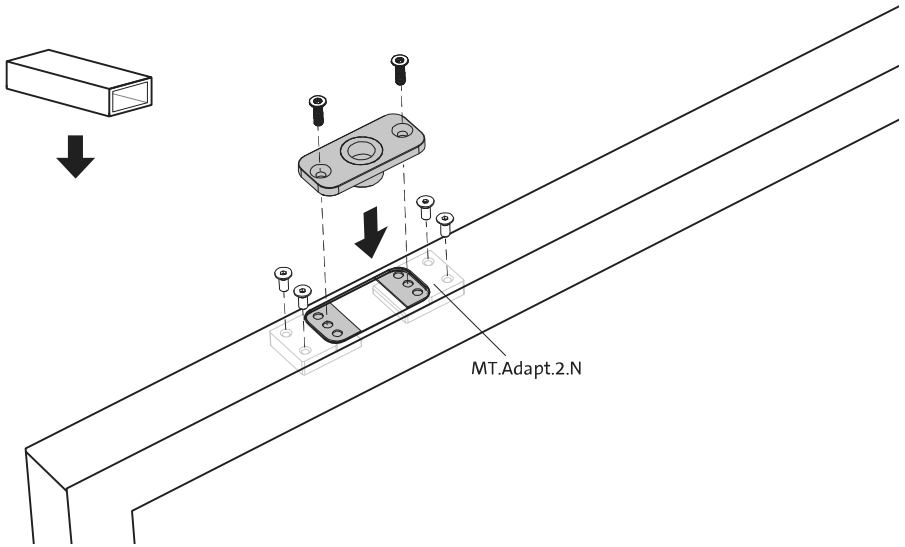

FP.M.X.X.FS.SS

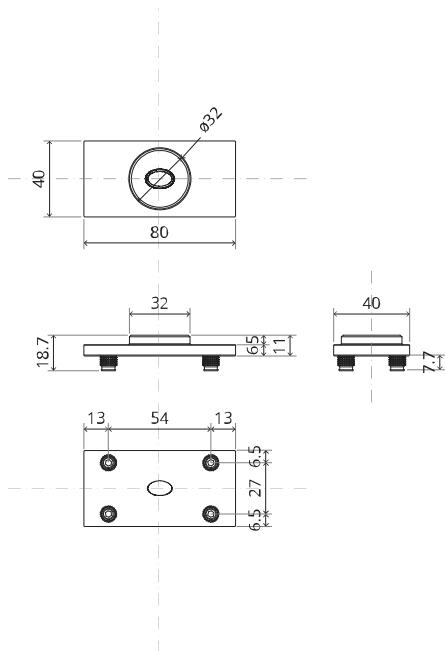
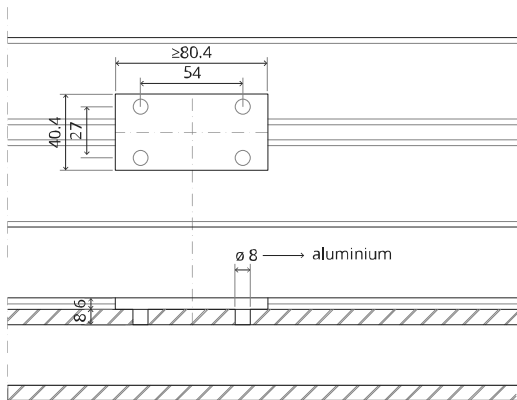



FP.M.X.X.FR.SS

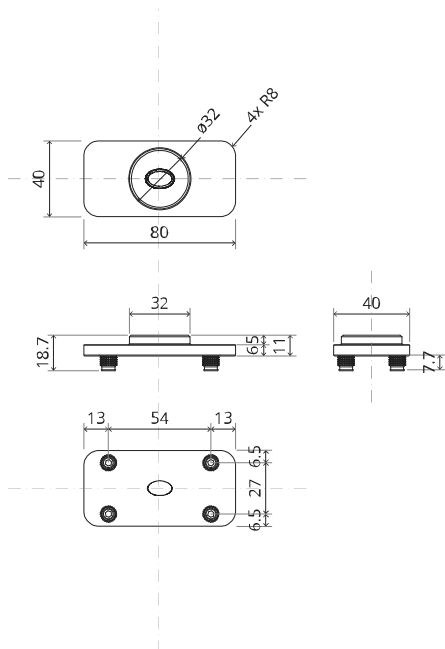
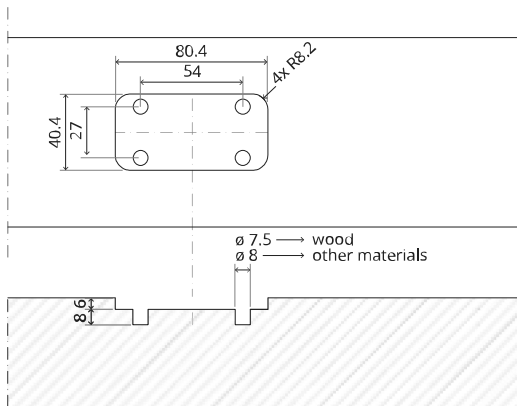



Mounting instructions

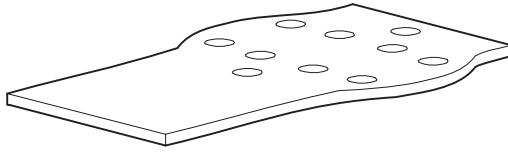

FJ.MT.DT.M

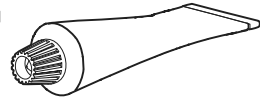

FJ.MT.ZS



FJ.MT.AK3

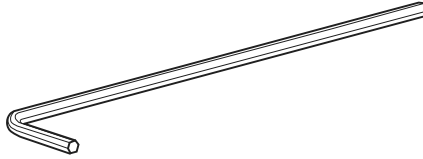

FJ.MT.AK5x24



10x FJ.Tx.4.0X50.PKDD



FJ.Bit.Tx20

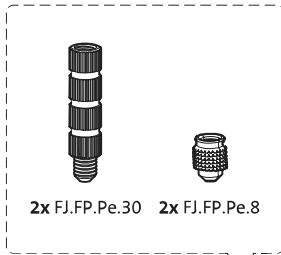

2x FJ.FP.Pe.30 2x FJ.FP.Pe.8

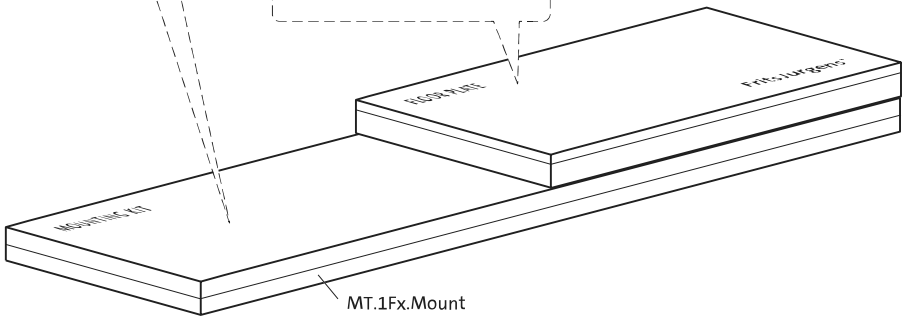

MT.1Fx.Mount

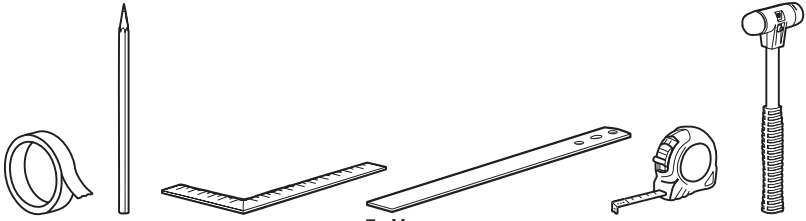

To.M

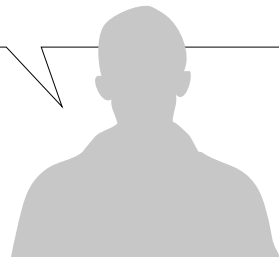
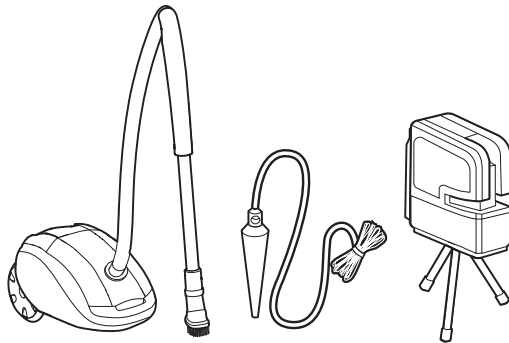
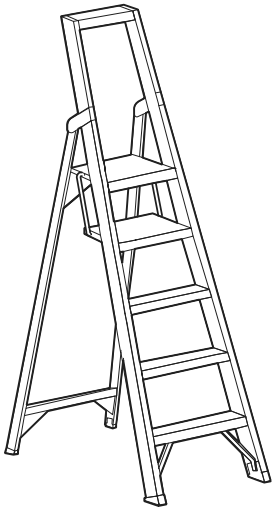
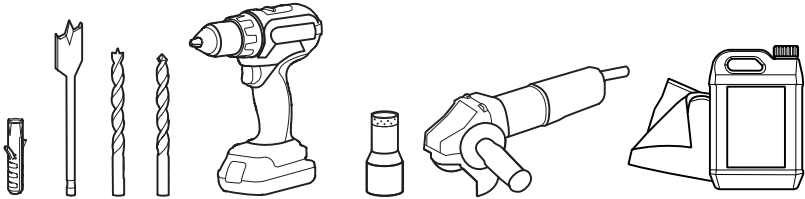

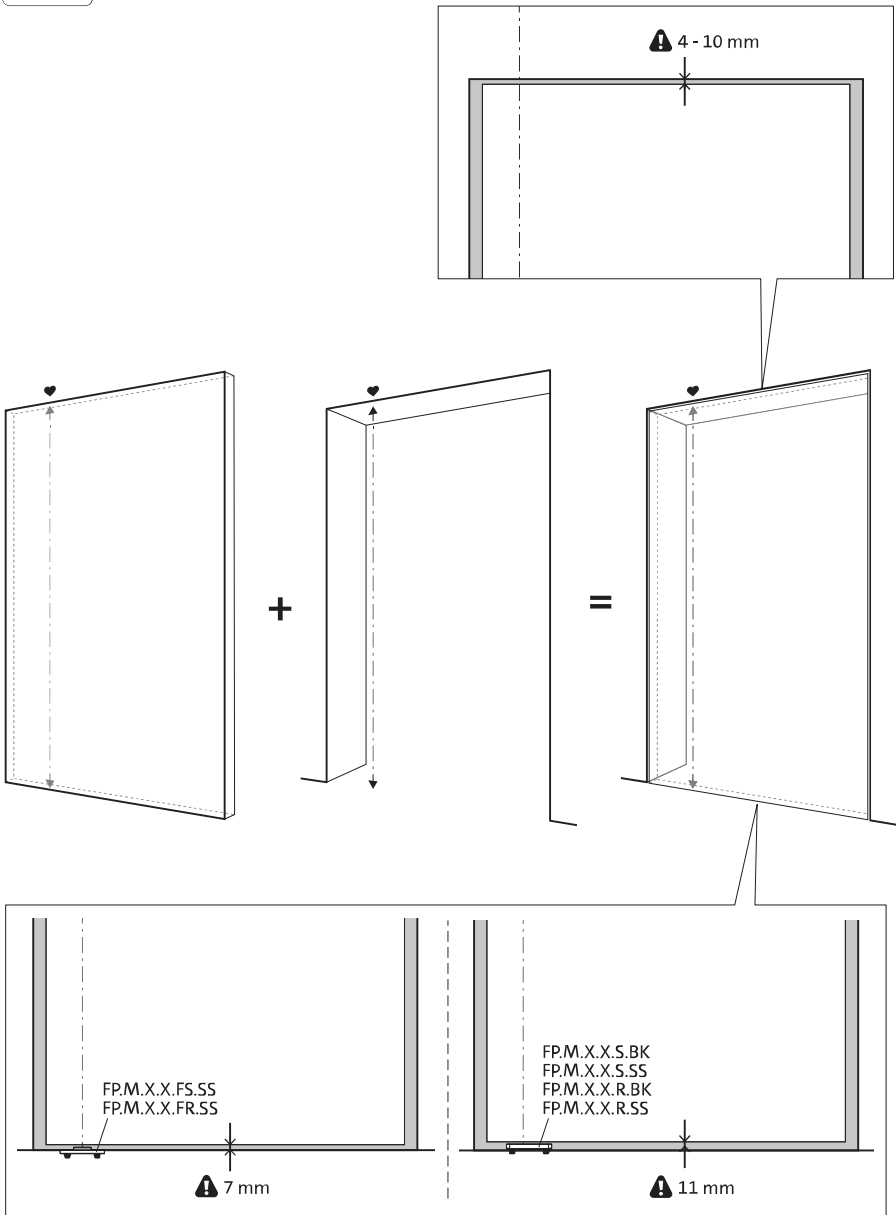



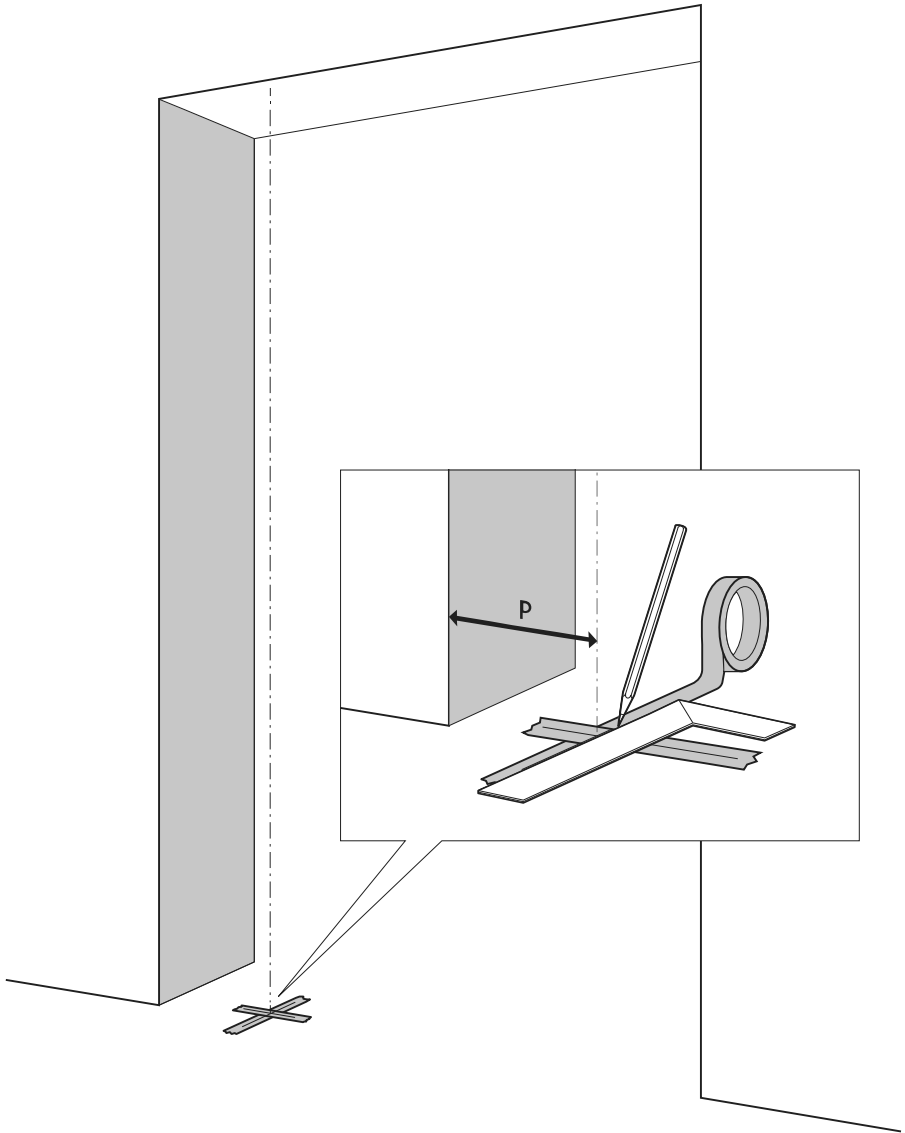

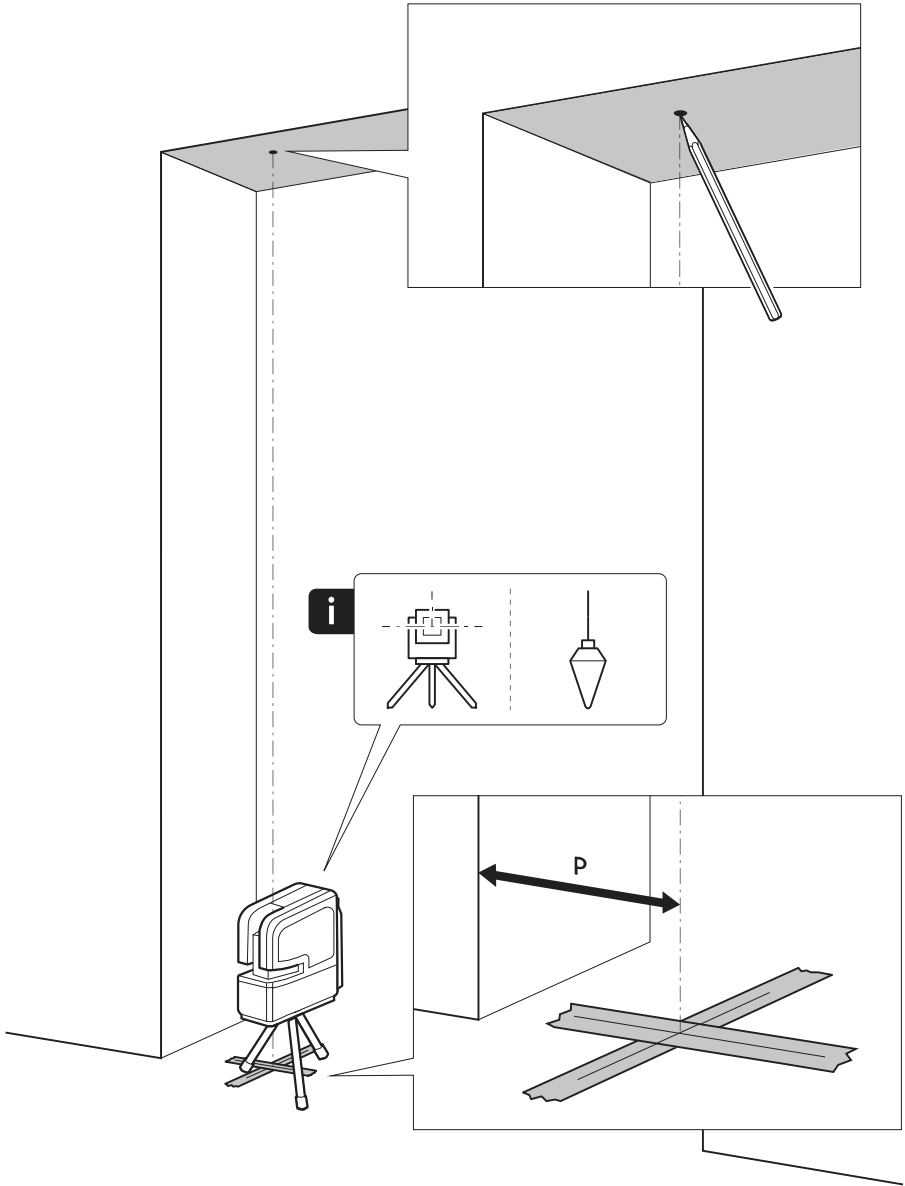
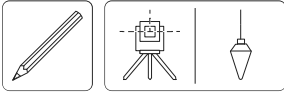

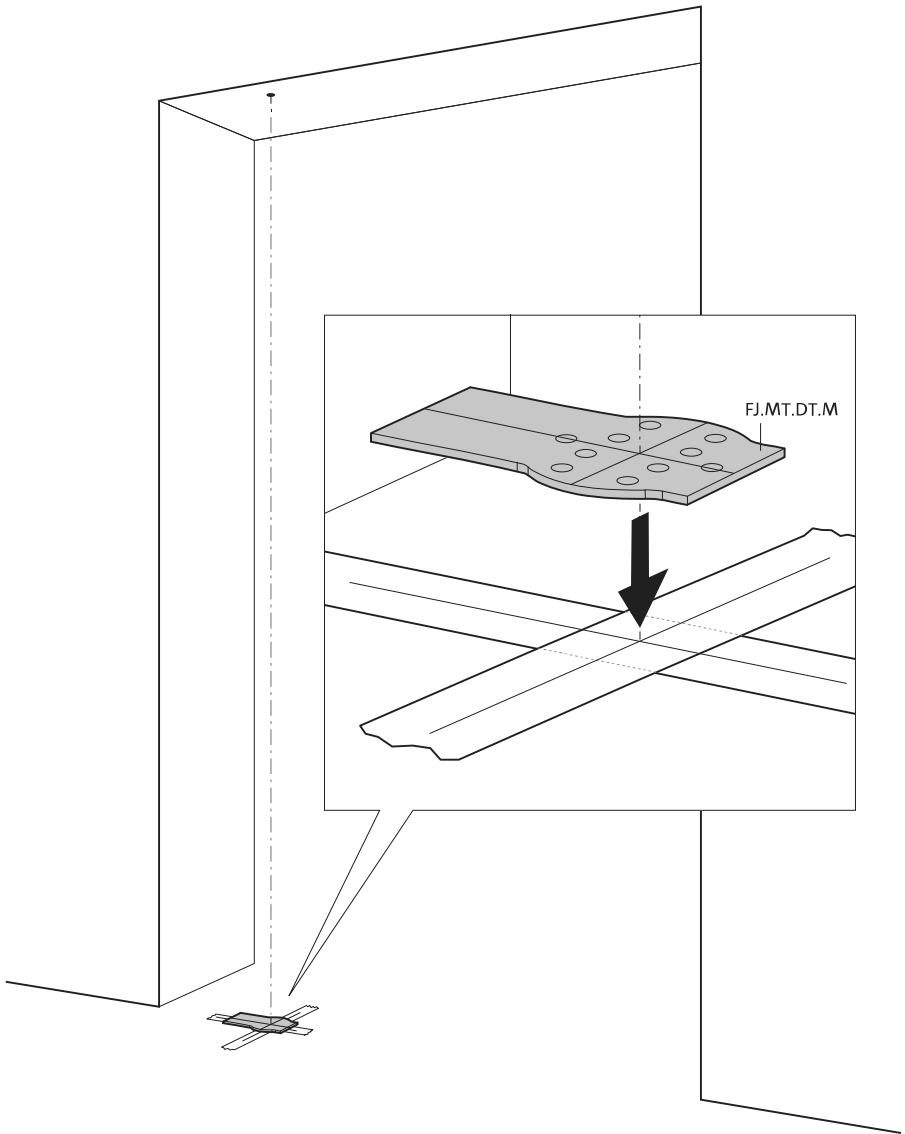

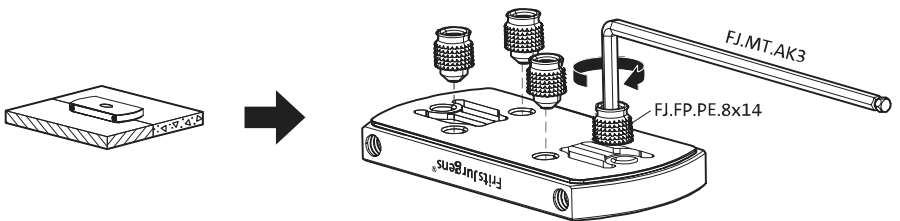
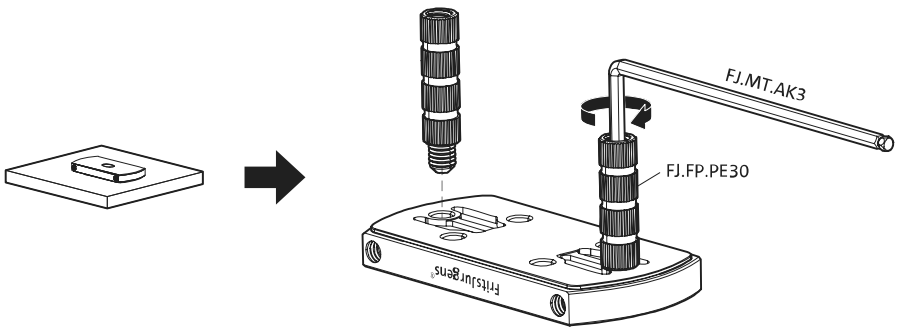
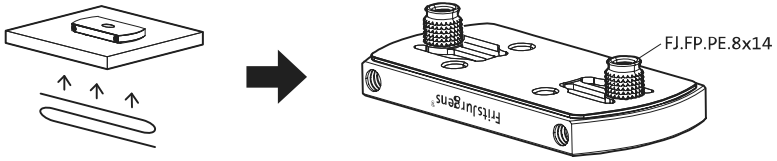

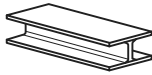

ø8 mm (5/16")

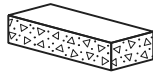

ø8 mm (5/16")

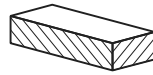

ø7.5 mm (19/64")

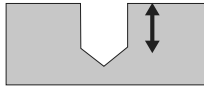

8 mm (5/16")



8 mm (5/16")

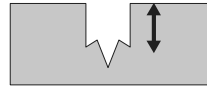

8 mm (5/16")

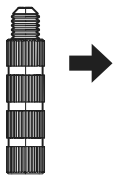

30 mm (13/16")



30 mm (13/16")

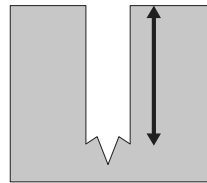

30 mm (13/16")

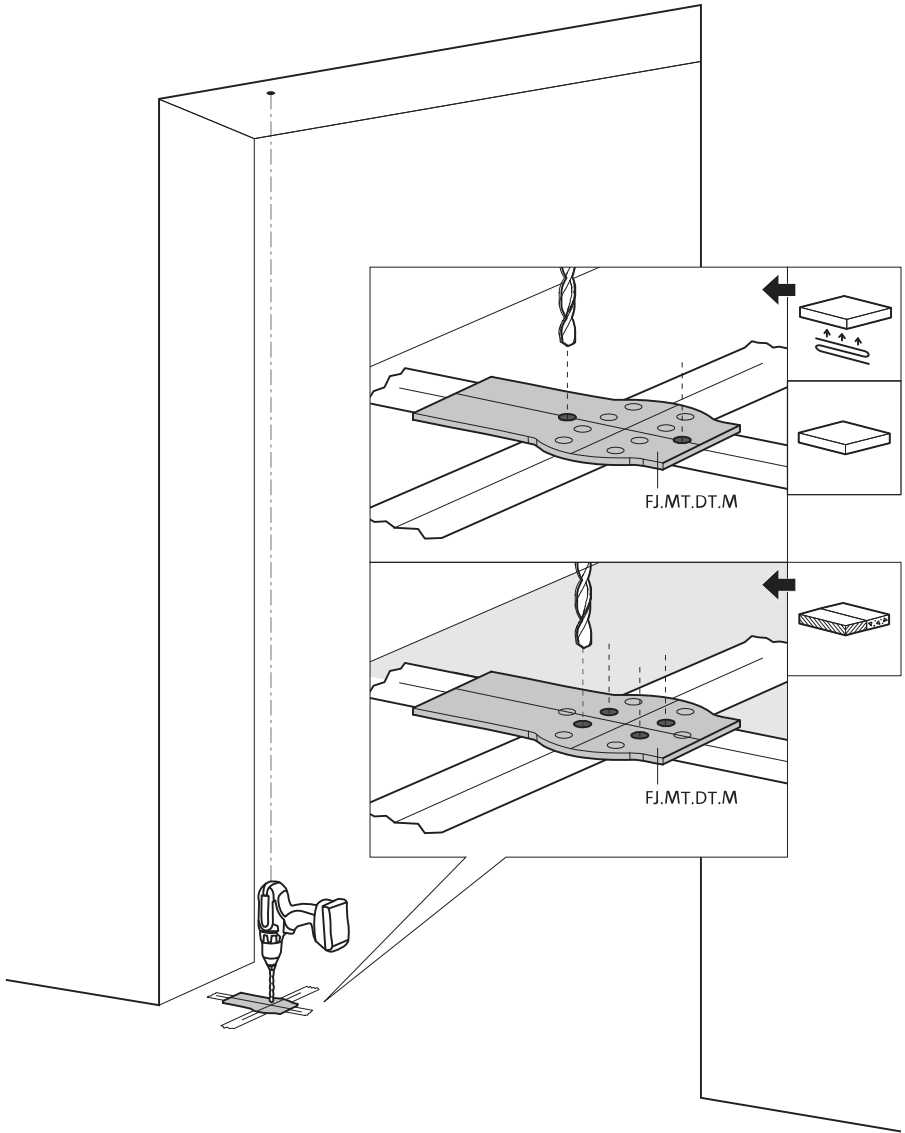





1



2

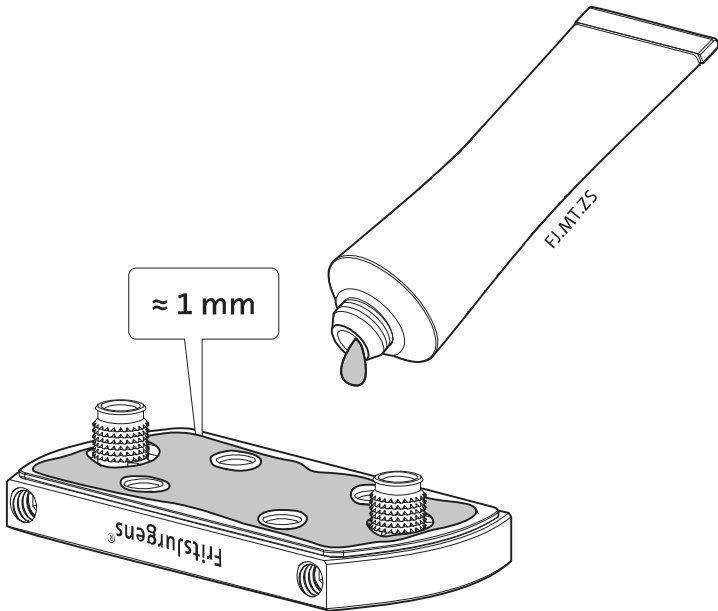

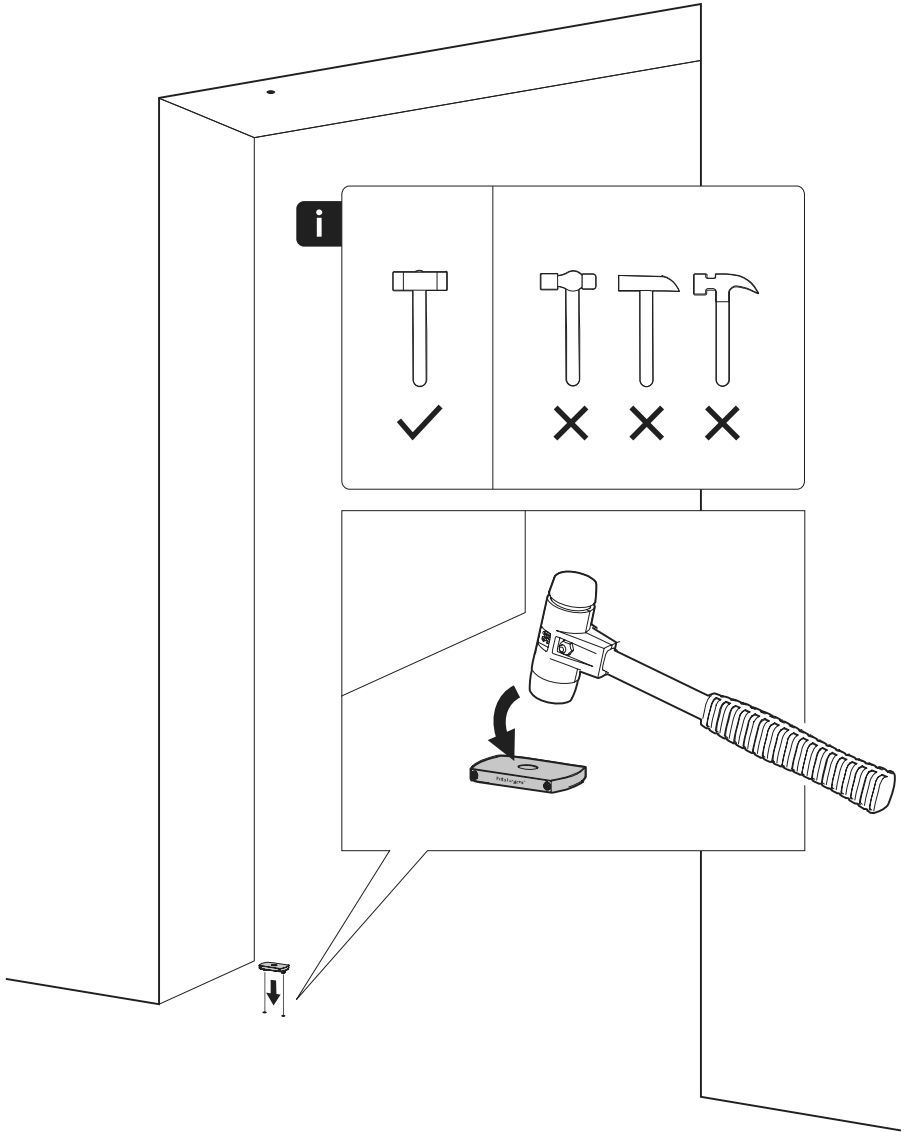

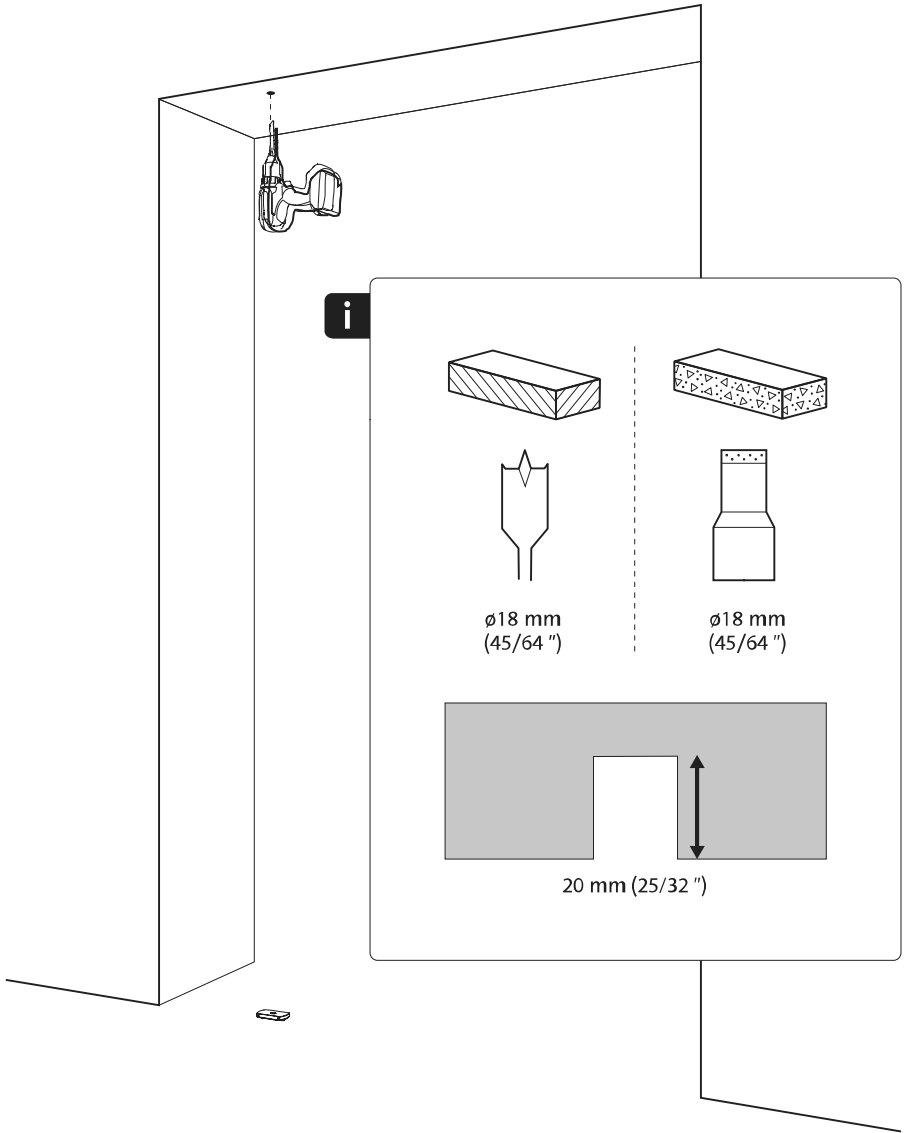



1

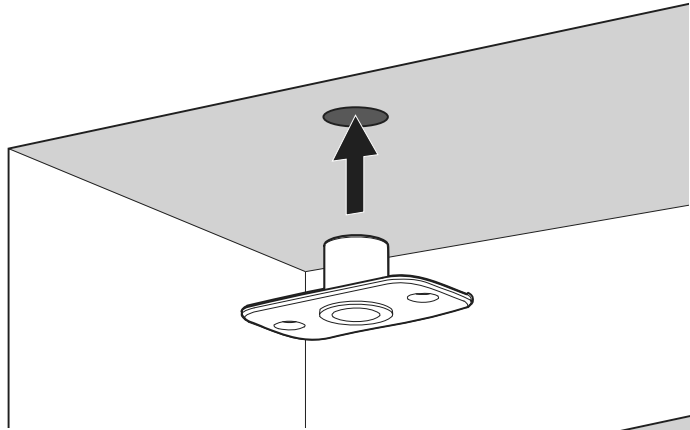

2

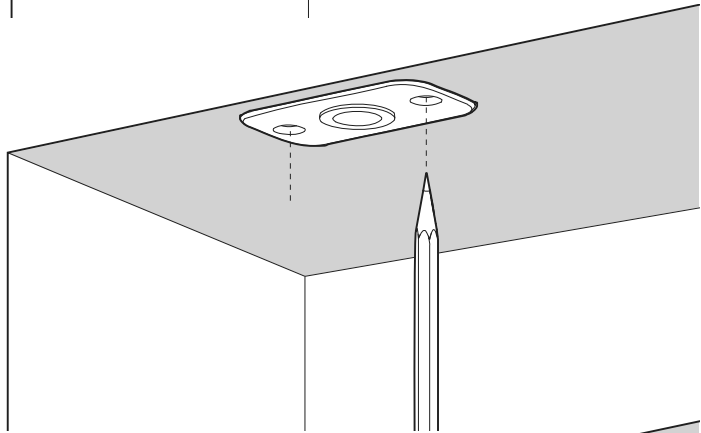

3

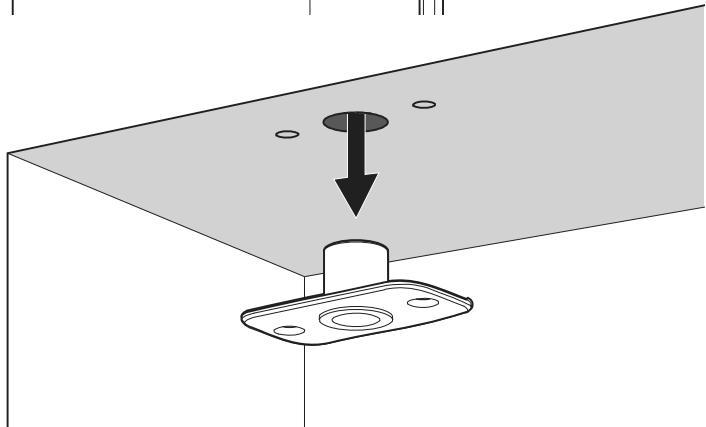



1

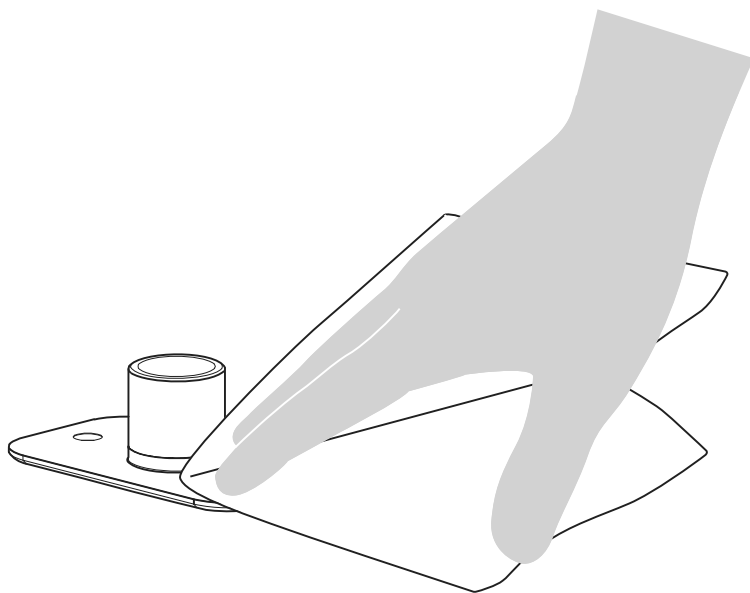

2

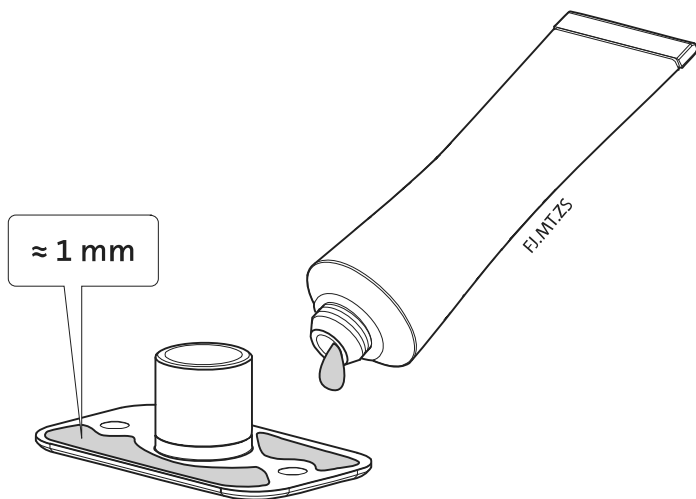

≈ 1 mm

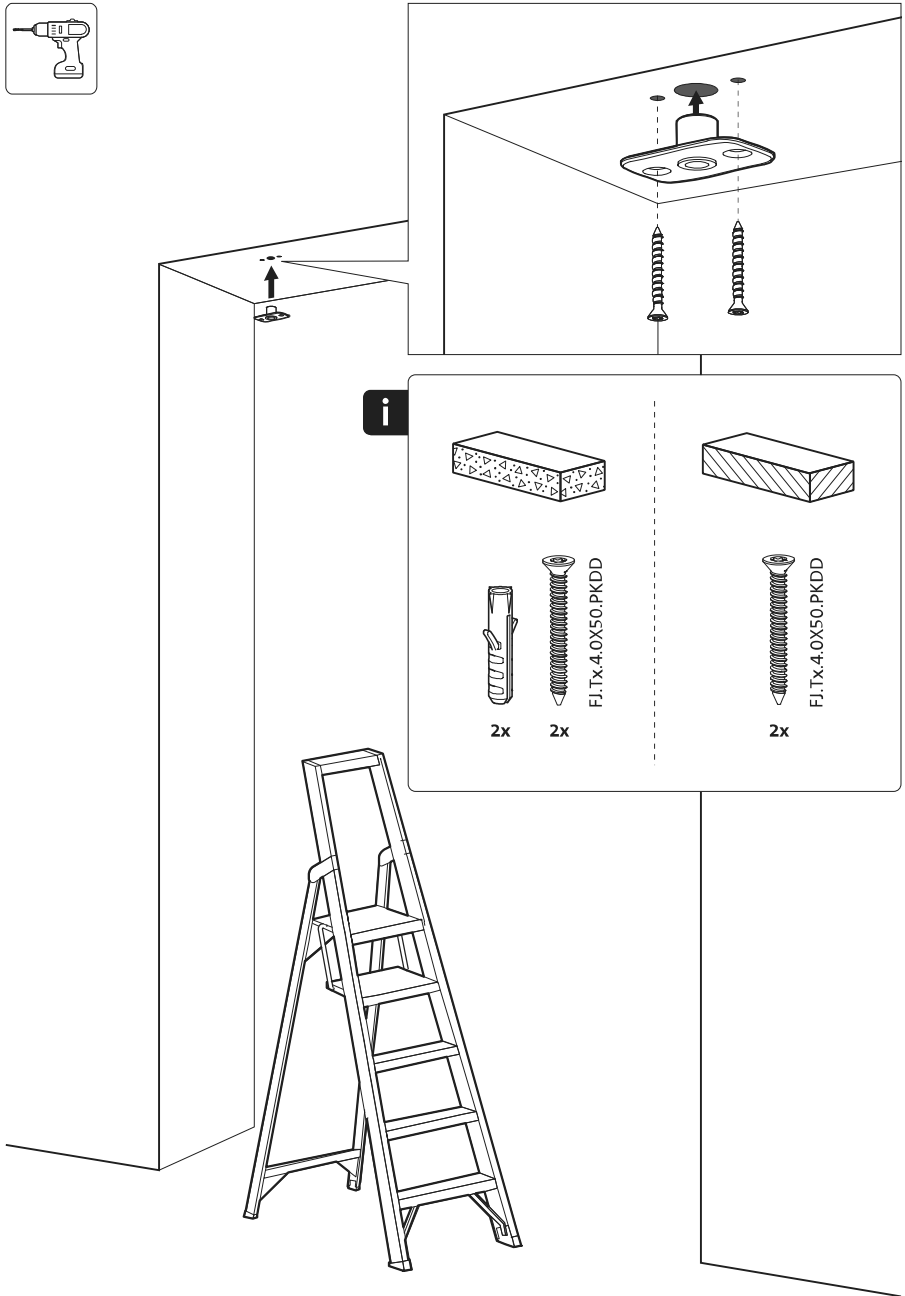

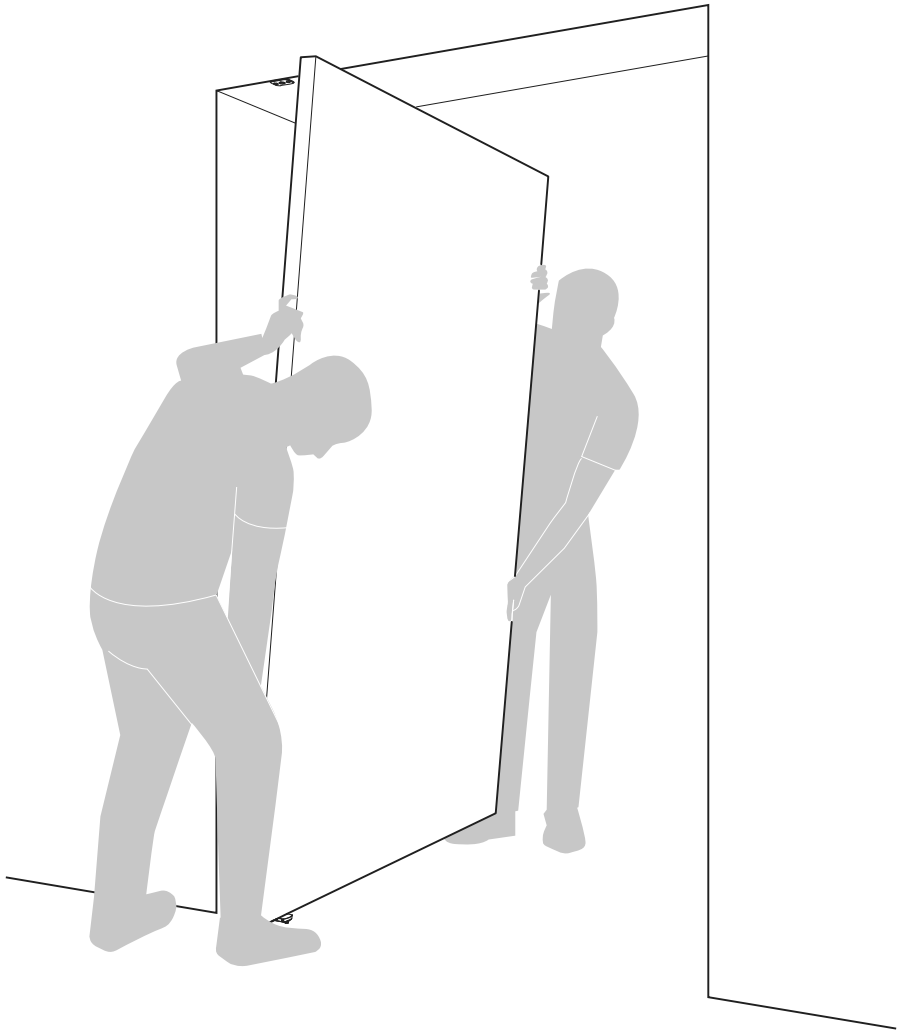

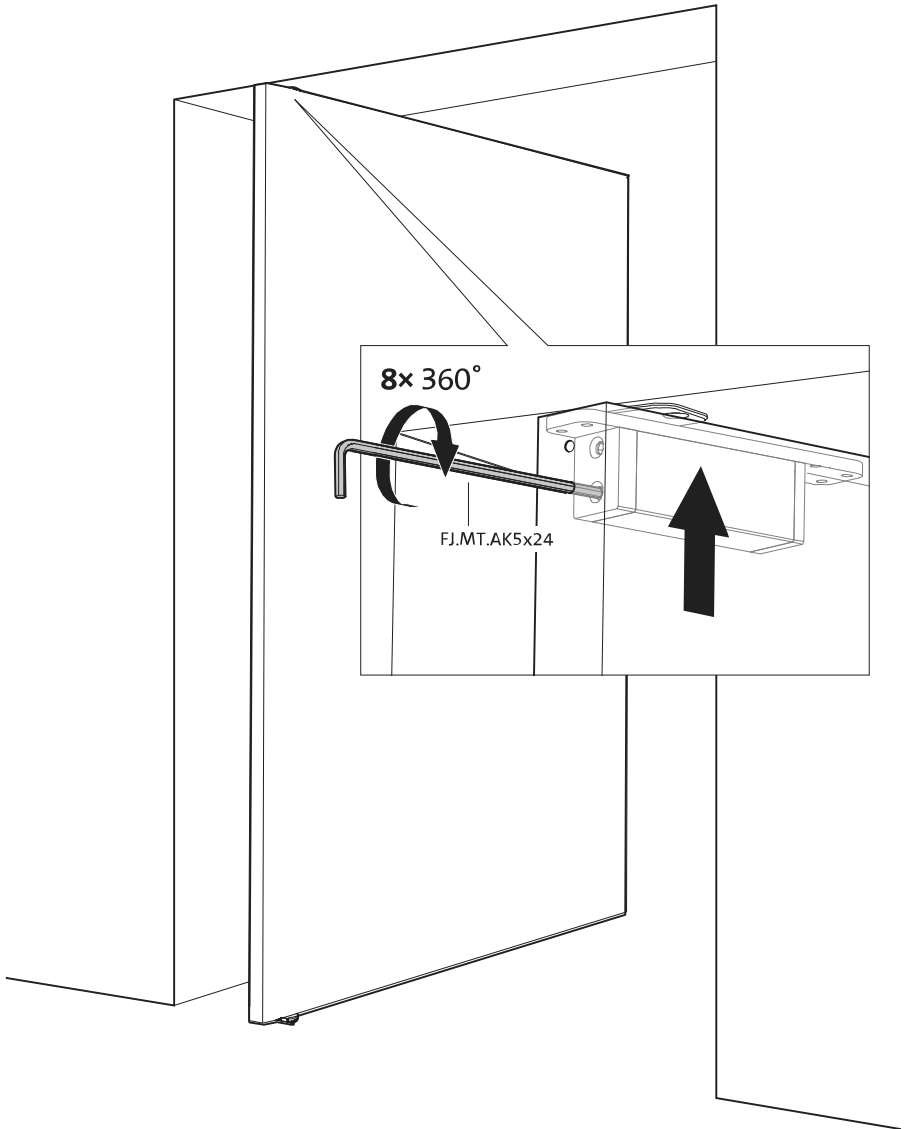
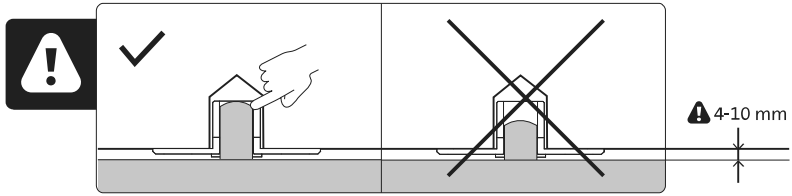

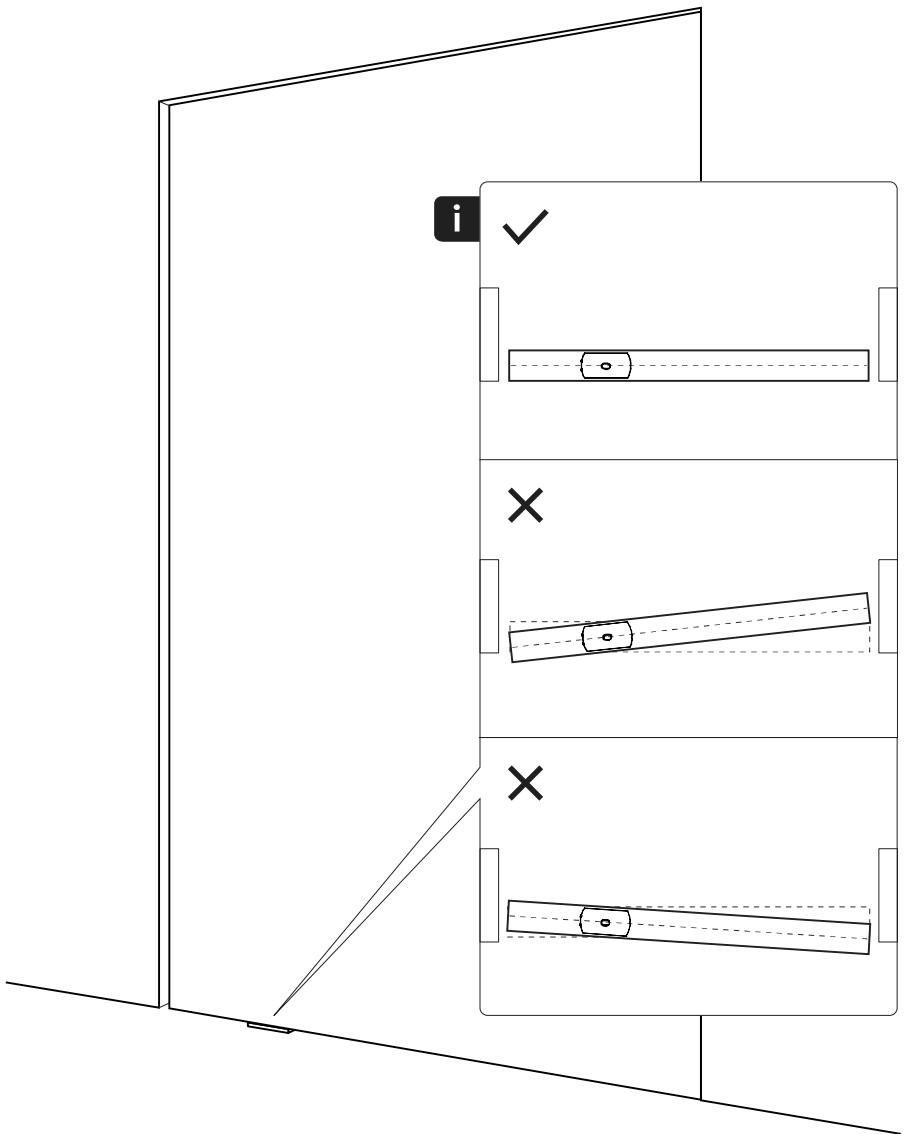

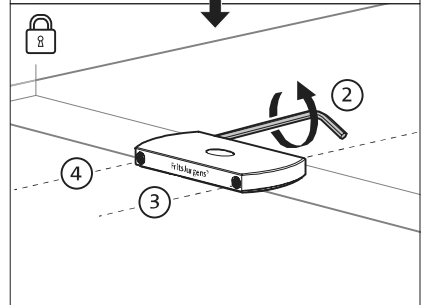
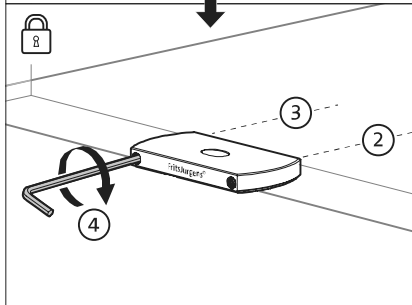
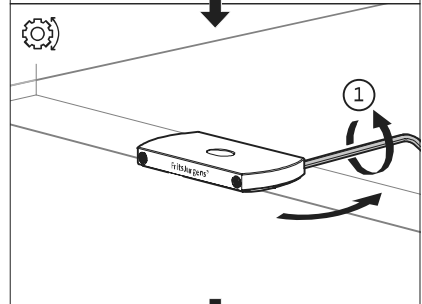
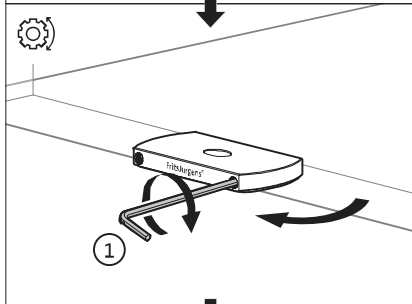
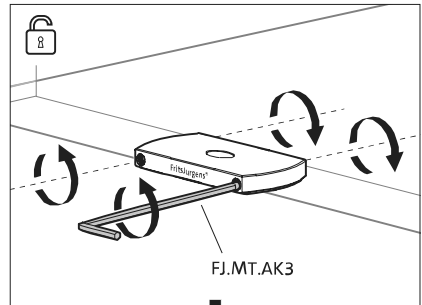
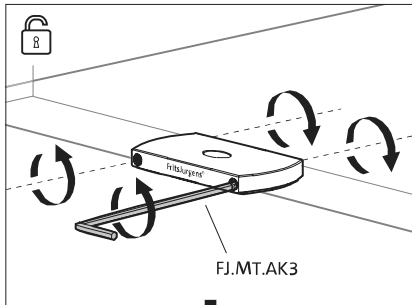
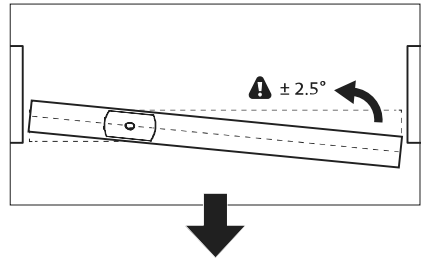
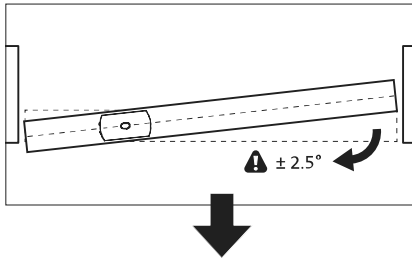

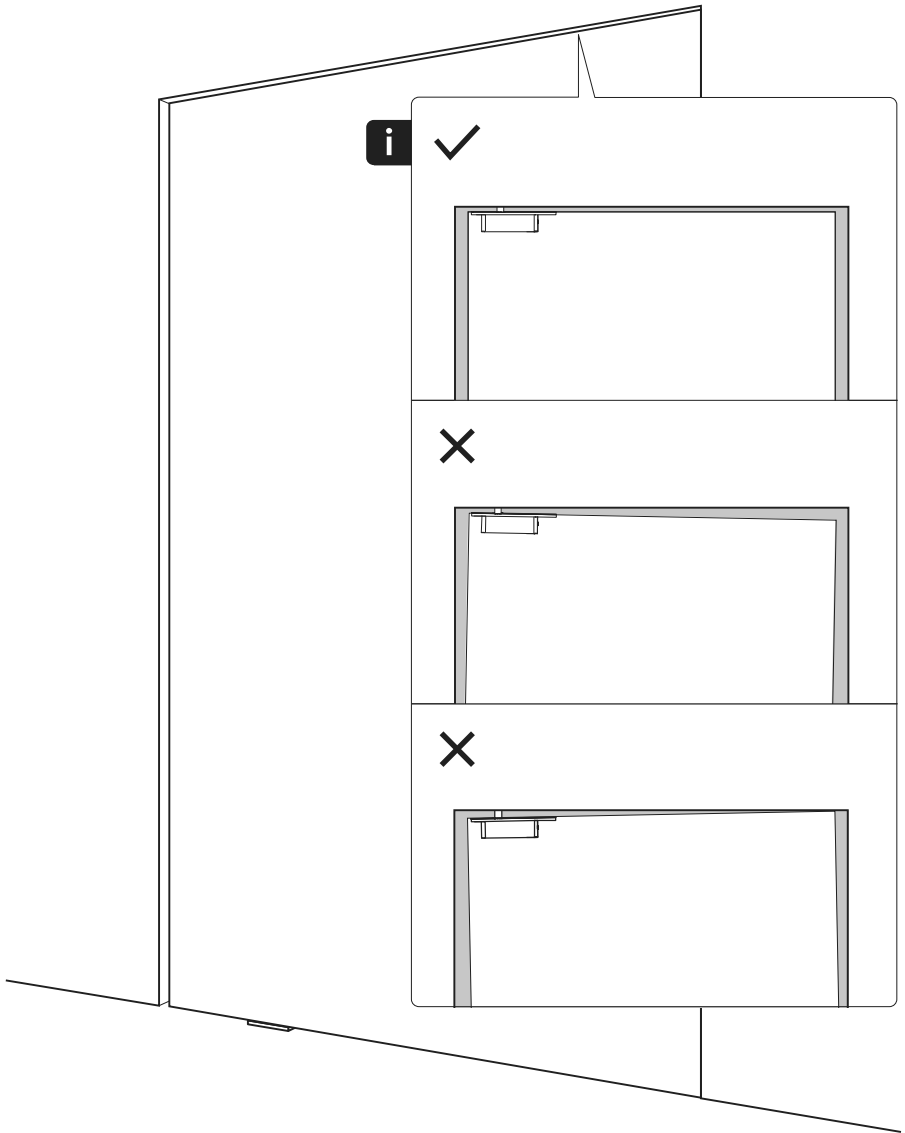

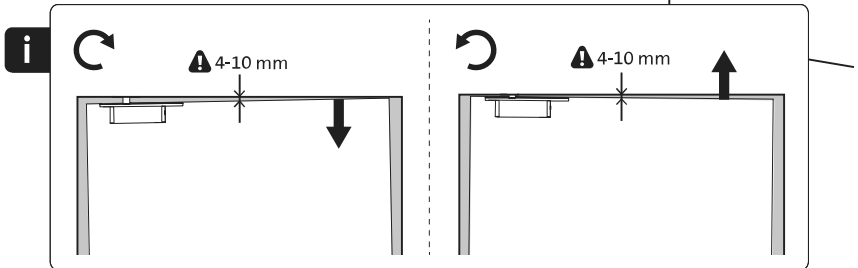
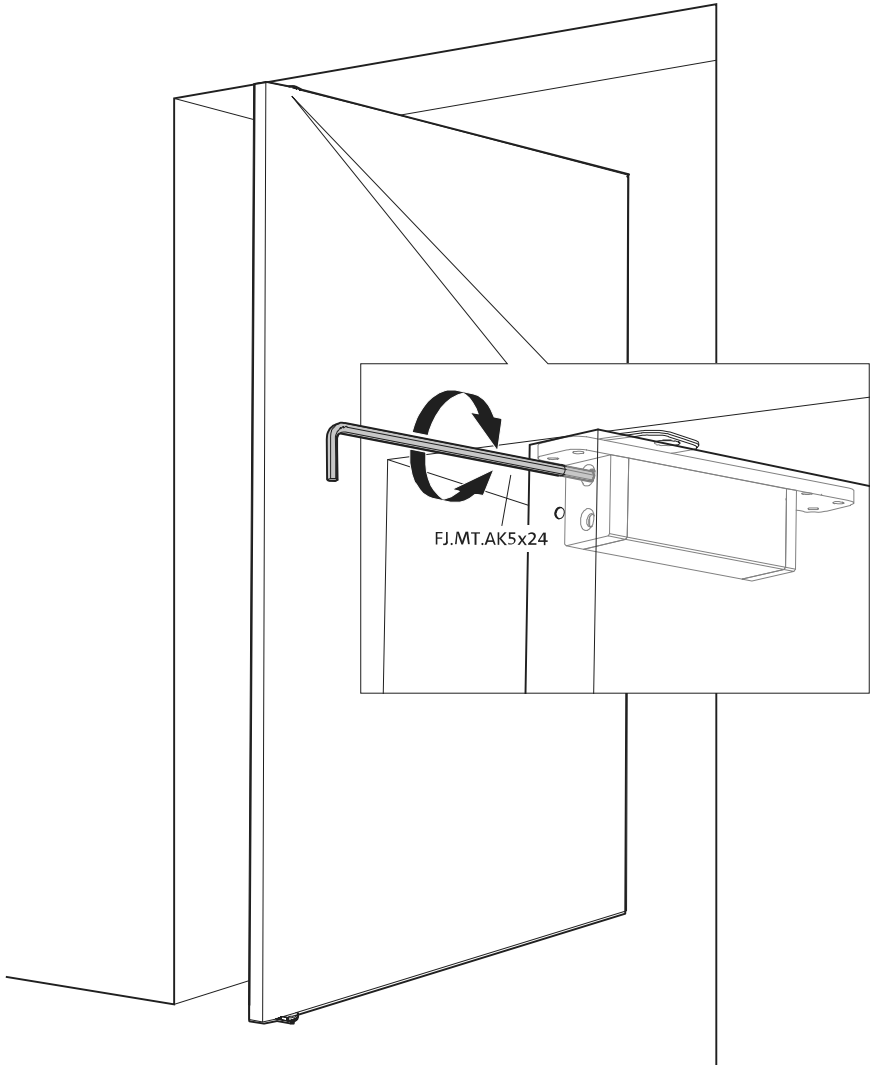

Disassembly instructions

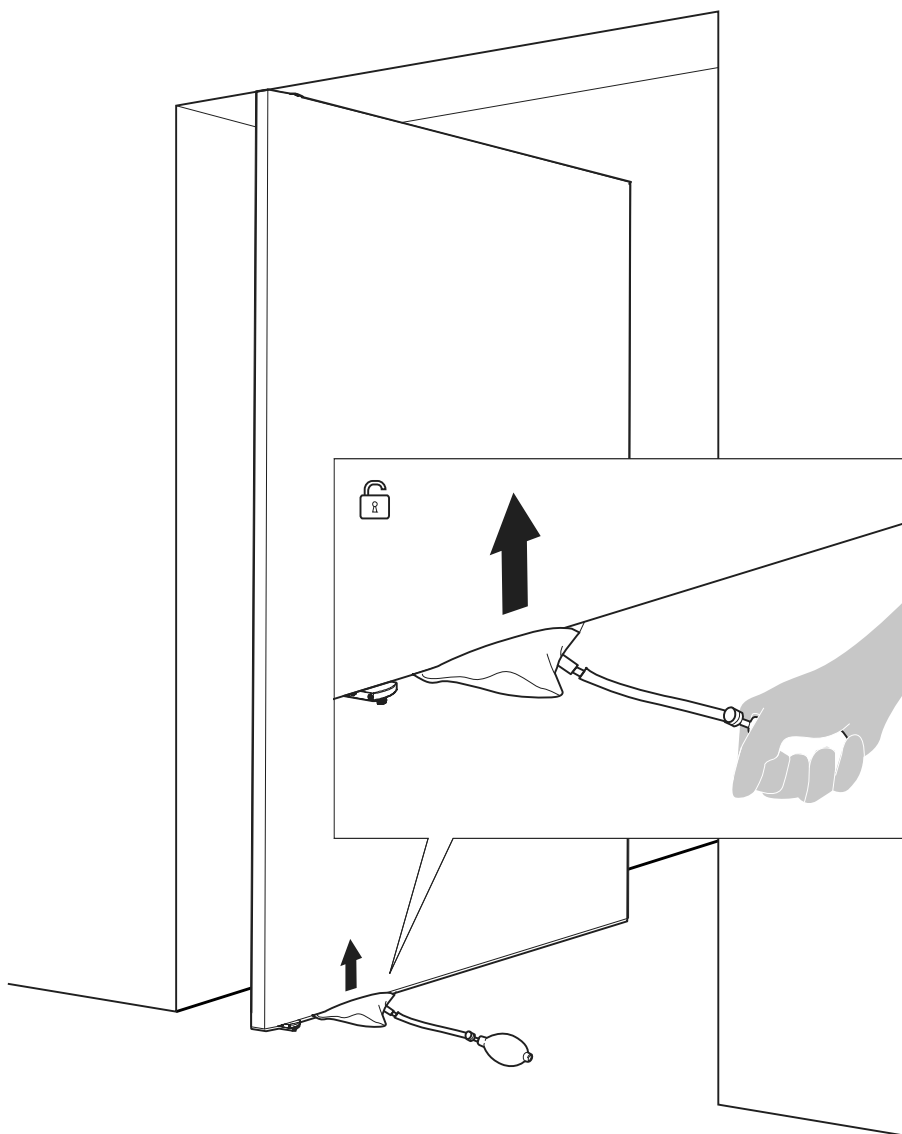

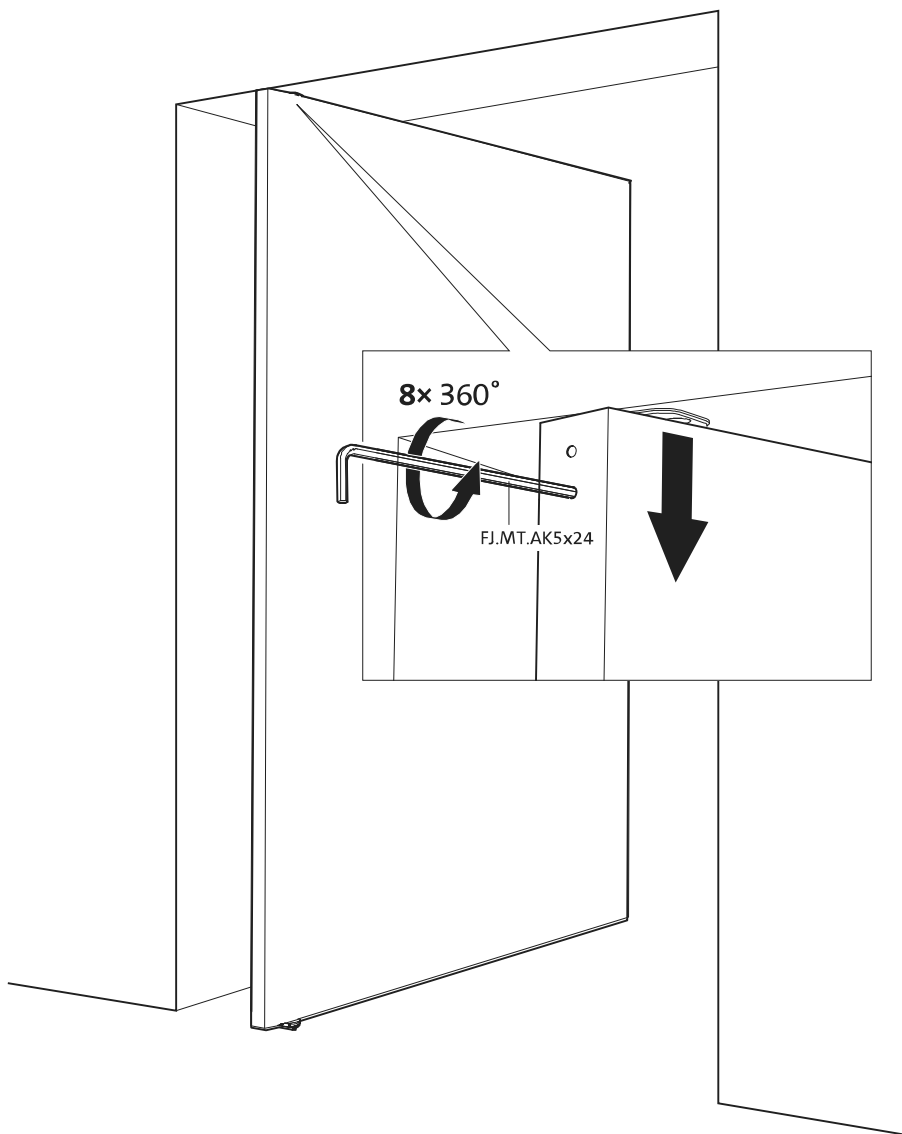



FritsJurgens International

A. Einsteinlaan 1
The Netherlands
9615 TE Kolham
+31 598 343 410
info@fritsjurgens.com

FritsJurgens Dubai Branch

DLC-OP-A2-4-0029
Dubai South
Dubai
United Arab Emirates
+971 4 820 8106
+971 58 137 2611
dubai@fritsjurgens.com
fritsjurgens.com

Copyright © FritsJurgens®
BP.One.70.G.X.XX



