

System One
Technical documentation
Functionalities and specifics



Overview	3
Components	4
Functions	5
Bottom pivots	7
Variants	8
Top pivots	9
Installation inside the door	10
Installation in the head jamb	11
Ceiling plates and Receiver	13
Ceiling plates	14
Receiver	14
Floor plates	15
Installation on the floor	16
Sunk into the sill	17
Technical checklist	19
Top and bottom gap	20
Side gaps	21
Milling and components	23
System One 70 mm	24
System One 40 mm	26
Top pivot 70 mm Class G	28
Top pivot 40 mm Class G	29
Top pivot Reversed	30

Overview

System One is the most ideal pivot hinge for narrow profile doors. With a height of just 18 mm, this pivot hinge can be applied in a broad range of pivot door designs and applications.

Components

Our systems always consist of the following components:

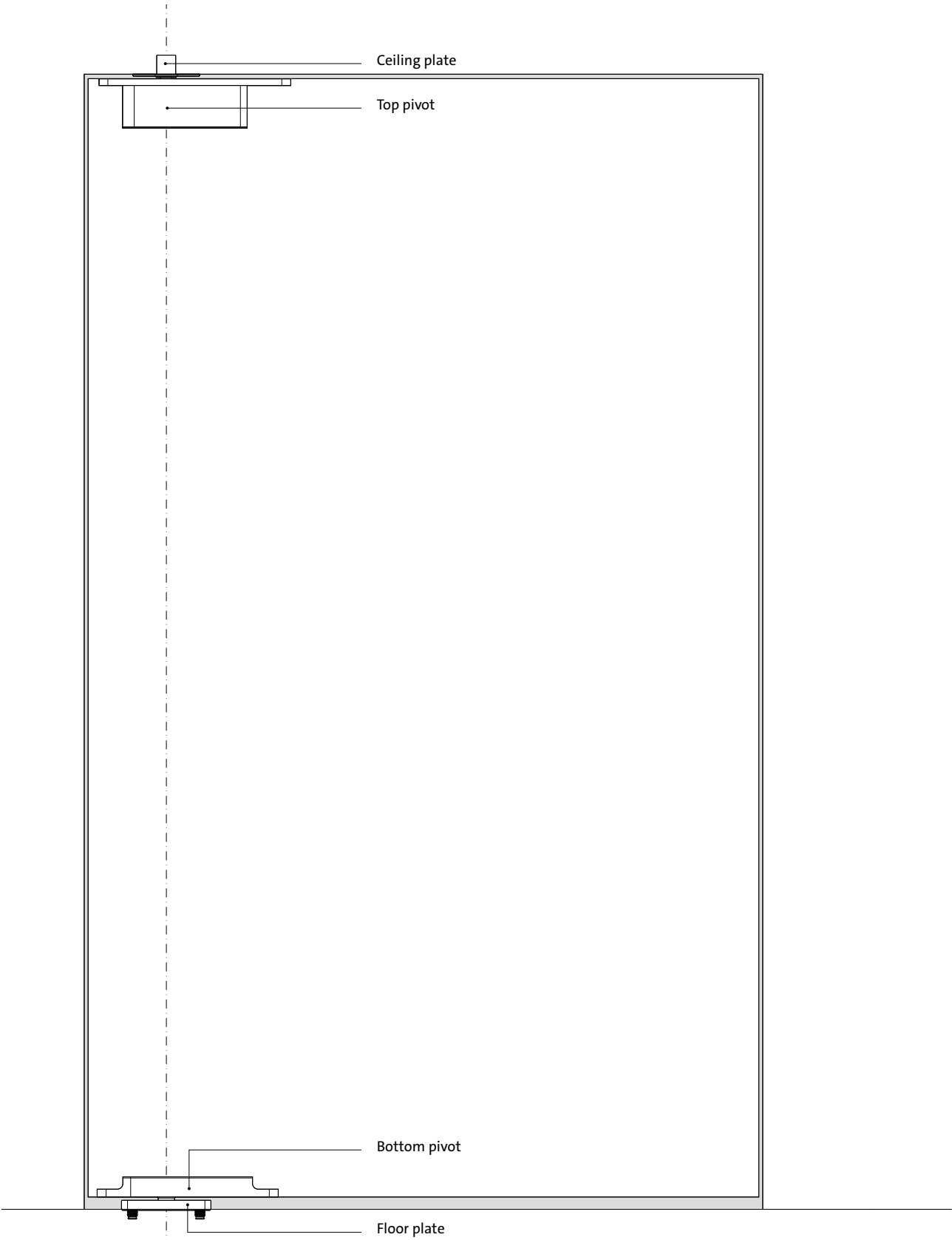

Functions

Rotation	Revolving [door]: 360° Double-acting: 180° Single-acting: 90°
Hold positions	No
Free swing	Yes
Self-closing	No
Door weight	Class G: up to 500 kg

Rotation

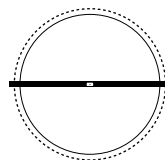

Revolving [door]

This FritsJurgens pivot system enables a door to revolve 360°.

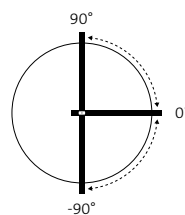

Double-acting

Double-acting means that the pivot door can be opened towards both sides.

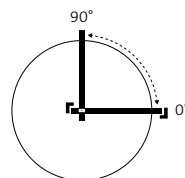

Single-acting

Single-acting means that the pivot door can only be opened towards a single side. This is enforced by an external stop such as the door frame.

Bottom pivots

It all hinges on the bottom pivot. Our bottom pivots are easily applicable to the side as well as to the middle of the door.

Variants

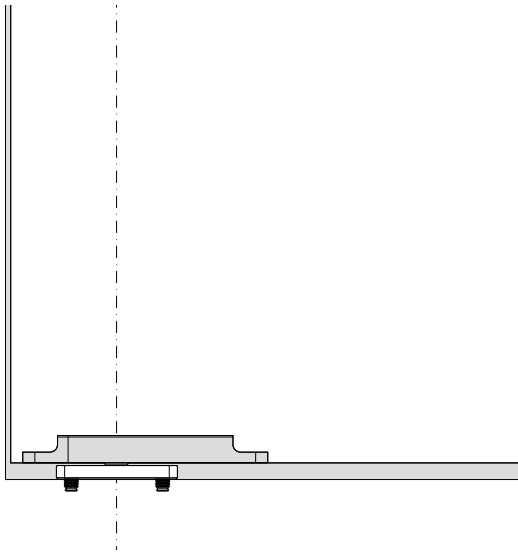

System One 70 mm

162 × 32 × 18 mm

Placement	Side to middle placement
Pivot point	Pivot point from 70 mm to middle placement
Cover plates	No

Compatible with

Top pivots	Top pivot 70 mm Class G Top pivot Reversed
Floor plates	Floor plate squared NA Floor plate round Floor plate Flush rounded Floor plate Flush squared

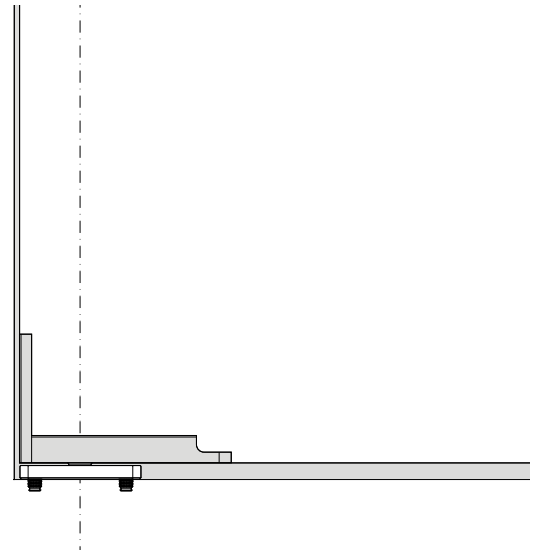

System One 40 mm

140 × 32 × 85 mm

Placement	Side placement
Pivot point	Fixed pivot point at 40 mm
Cover plates	Stainless steel Black

Compatible with

Top pivots	Top pivot 40 mm Class G
Floor plates	Floor plate squared NA Floor plate round Floor plate Flush rounded Floor plate Flush squared

Find out more about [top pivots](#) or [floor plates](#).

Top pivots

The top pivot anchors the pivot door between the floor and the ceiling.

Installation inside the door

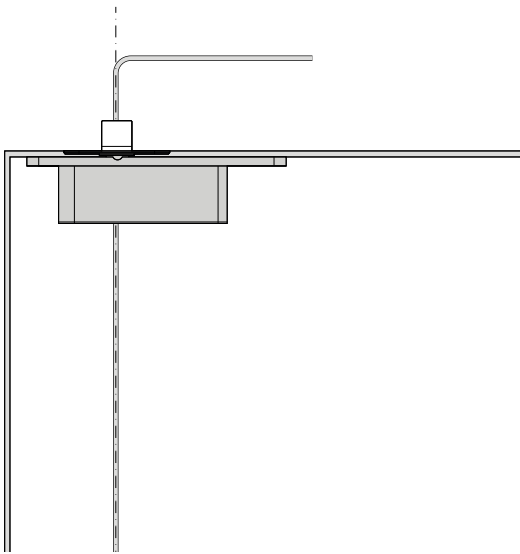

Top pivot 70 mm Class G

171.5 × 32 × 44 mm

Placement	Side to middle placement
Pin diameter	Ø15 mm
Pivot point	Pivot point from 70 mm to middle placement
Adjustment	From the side of the door: 5 mm to the left and 5 mm to the right
Cable grommet	Yes, Ø7.5 mm cable entry
Cover plates	No

Compatible with

Bottom pivots	System One 70 mm
Ceiling plates	Ceiling plate Class G

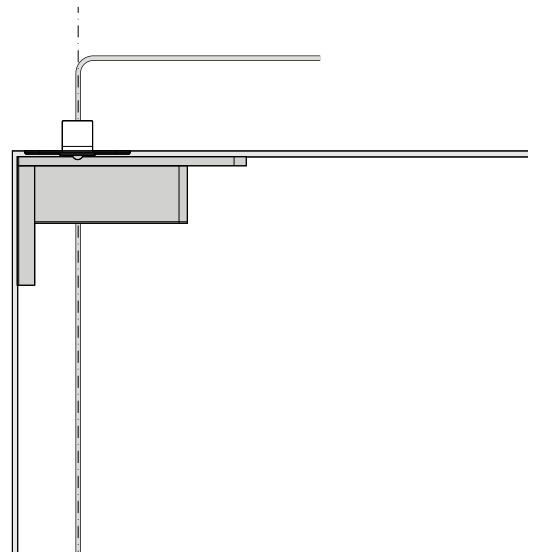

Top pivot 40 mm Class G

151.5 × 32 × 85 mm

Placement	Side placement
Pin diameter	Ø15 mm
Pivot point	Fixed pivot point at 40 mm
Adjustment	From the side of the door: 5 mm to the left and 5 mm to the right
Cable grommet	Yes, Ø7.5 mm cable entry
Cover plates	Stainless steel Black

Compatible with

Bottom pivots	System One 40 mm
Ceiling plates	Ceiling plate Class G

Find out more about [ceiling plates](#).

Installation in the head jamb

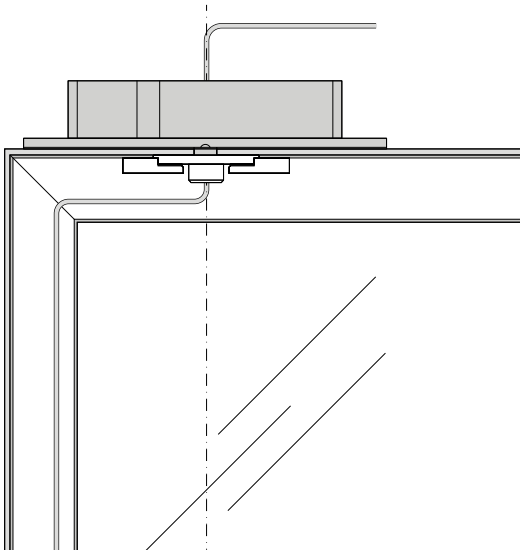

Top pivot Reversed

240 × 32 × 45 mm

Placement	Side to middle placement
Pin diameter	Ø15 mm
Pivot point	Pivot point from 130 mm to middle placement
Adjustment	From inside the door opening: 5 mm to the left and 5 mm to the right
Cable grommet	Yes, Ø7.5 mm cable entry
Cover plates	Stainless steel Black White

Compatible with

Bottom pivots	System One 70 mm
Ceiling plates	Receiver

Find out more about [ceiling plates](#) or [Receiver](#).

Ceiling plates and Receiver

Our ceiling plates and Receiver pair with the top pivots. The ceiling plates can be combined with all our top pivots, except for the Receiver. The top pivot Reversed pairs best with the Receiver to mount in the door.

Ceiling plates

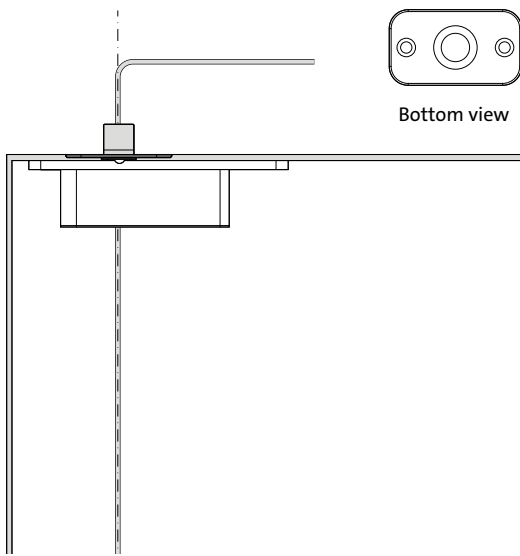

Ceiling plate Class G

70 × 40 × 23 mm

Colours Stainless steel
 Black

Pin diameter Ø15 mm

Compatible with

Top pivots Top pivot 70 mm Class G
 Top pivot 40 mm Class G

Receiver

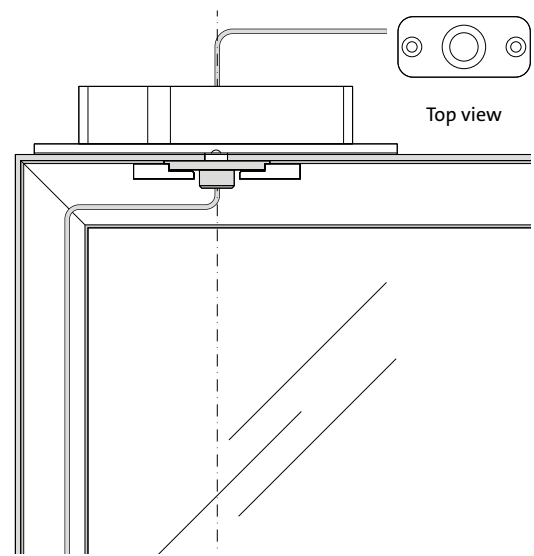

Receiver

70 × 32 × 18 mm

Colours Stainless steel

Pin diameter Ø15 mm

Compatible with

Top pivots Top pivot Reversed

Accessories Adapters

Floor plates

Our floor plates support the door at the bottom. They are either surface mounted with only short pins anchoring into the floor or recessed in the sill. Their compact design makes installation a lot easier, and they combine perfectly with pre-installed underfloor heating.

Installation on the floor

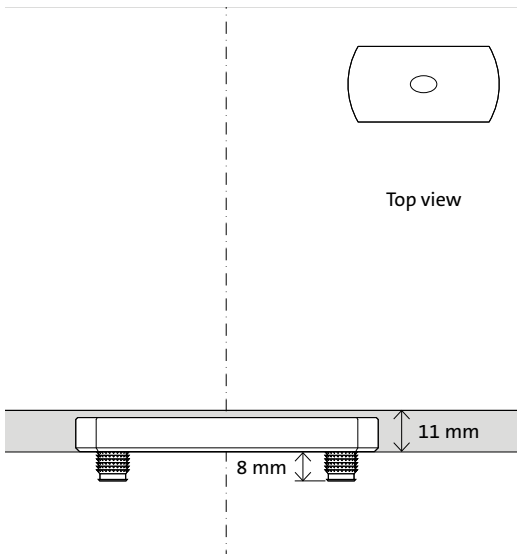

Floor plate squared NA (non-adjustable)

80 × 40 × 9 mm

This floor plate is customized for System One. It does not support radial adjustment features.

Mounting pins	Two or four 8 mm pins for optimal stability between two floor types. Or two 30 mm pins for mounting on layered floor materials.
Undercut	11 mm
Colours	Stainless steel Black
Radial adjustment	No

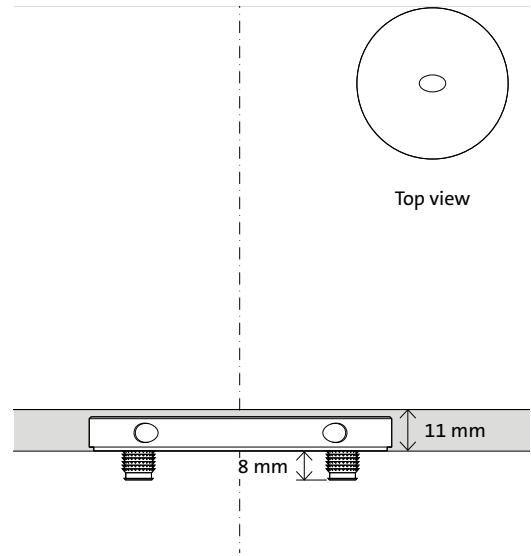

Floor plate round

Ø80 × 9 mm

Especially for aesthetic purposes, we feature the round 80 mm floor plate.

Mounting pins	Four 8 mm pins
Undercut	11 mm
Colours	Stainless steel Black
Radial adjustment	Yes, 2.5° to the left and 2.5° to the right

Sunk into the sill

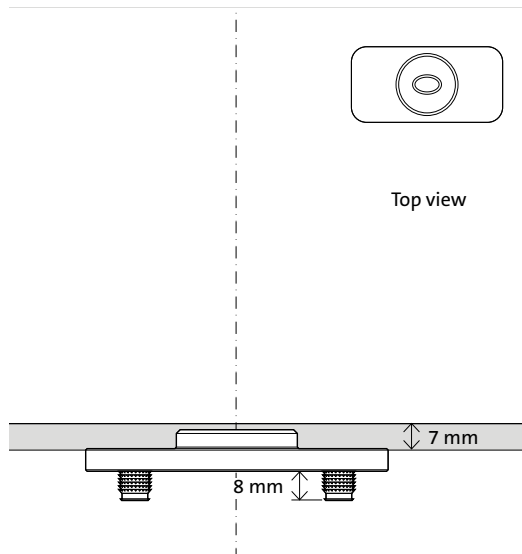

Floor plate Flush rounded

80 × 40 × 11 mm

Floor plate Flush rounded offers the possibility to recess your floorplate in the door frame. If you plan to use drop seals to prevent draught or as a seal for an exterior pivot door, a floor plate Flush is the floor plate you need.

Mounting pins	Four 8 mm pins
Undercut	7 mm
Colours	Stainless steel
Radial adjustment	No

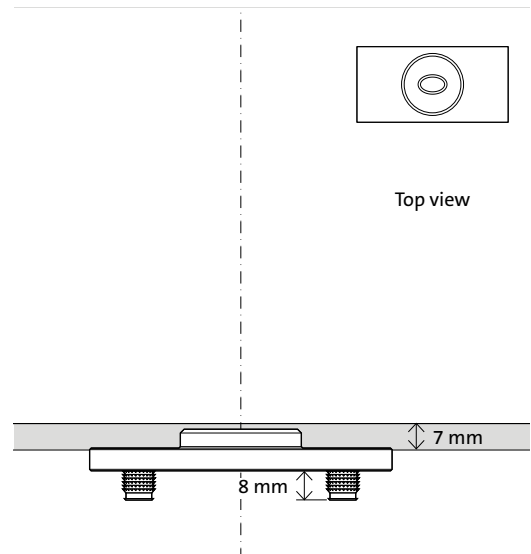

Floor plate Flush squared

80 × 40 × 11 mm

Floor plate Flush squared offers the possibility to recess your floorplate in the door frame. If you plan to use drop seals to prevent draught or as a seal for an exterior pivot door, a floor plate Flush is the floor plate you need.

Mounting pins	Four 8 mm pins
Undercut	7 mm
Colours	Stainless steel
Radial adjustment	No

Technical checklist

To make sure you have every technical specific you need, we have compiled a smart checklist.

Top and bottom gap

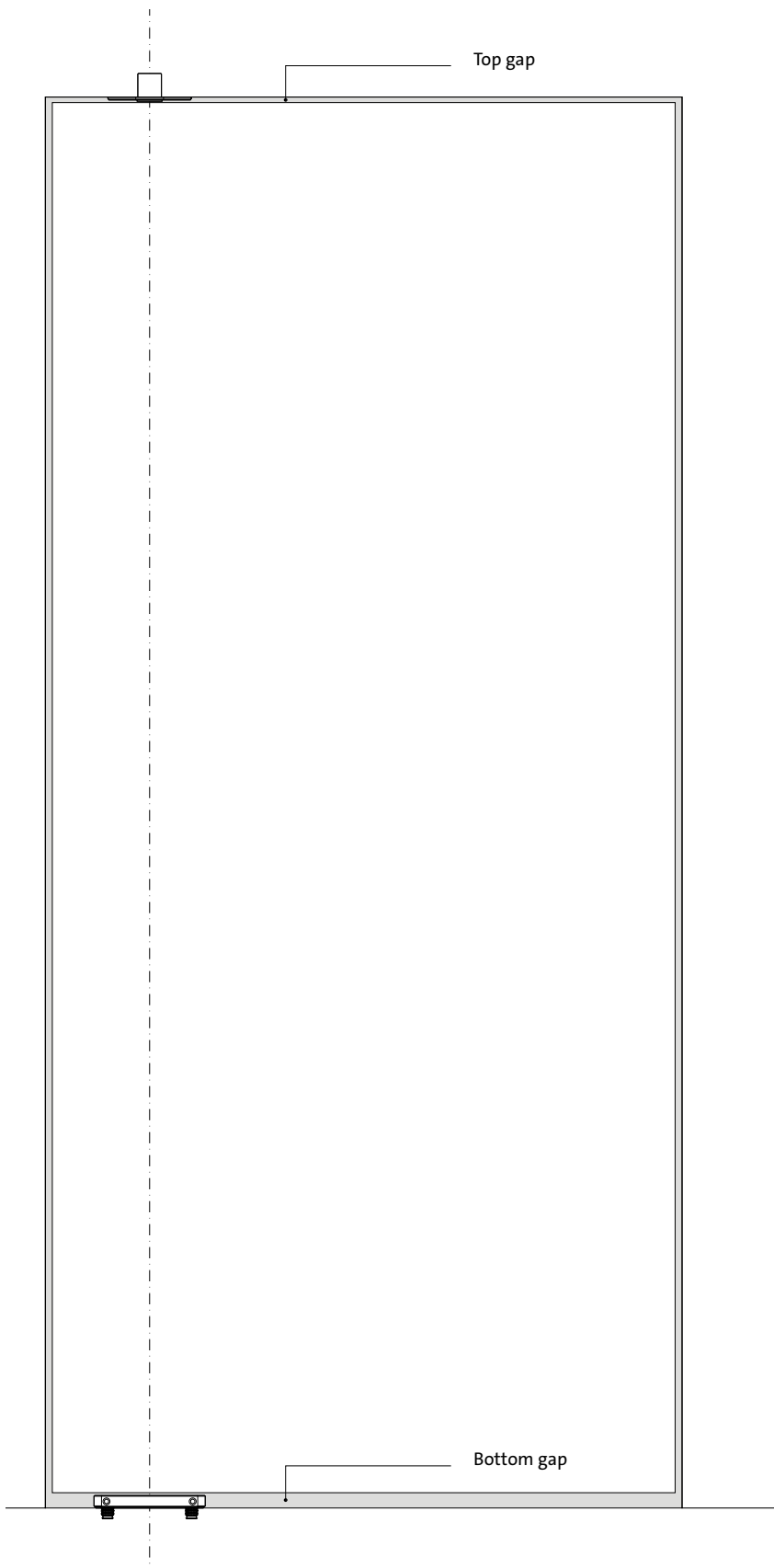

Top gap

The distance between ceiling and top of the door should be 4-10 mm*.

* In all situations, beware of sagging.

Bottom gap

The opening between the bottom of the door and the floor depends on the floor plates that are used.

Floor plate squared NA	11 mm
Floor plate round	11 mm
Floor plate Flush rounded	7 mm
Floor plate Flush squared	7 mm

Side gaps

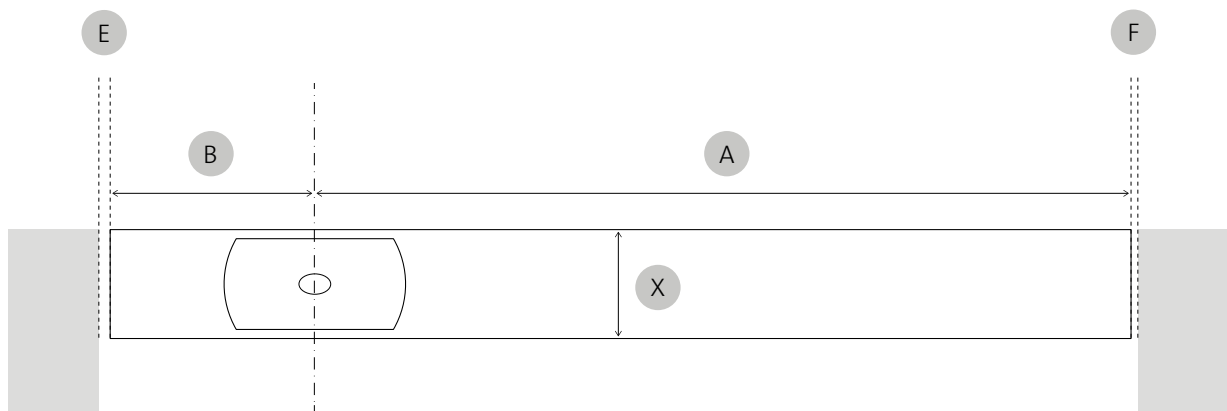

- X Door thickness
- B Distance of pivot point to the near edge of the door
- A Distance of pivot point to the far edge of the door
- E Minimum gap left
- F Minimum gap right

The minimum gap at the side of the door depends on the thickness and the width of the door in relation to the position of the pivot point.

The outcome on left and right will be different. The calculation is made based on the radius of the door when turning. The smaller the radius (the pivoting side) and the thicker the door, the bigger the required gap between door and wall or frame.

Calculate the required gap dimensions with our Gap Calculator: www.fritsjurgens.com/gap-calculator.

Milling and components

We tried to keep our milling procedure as simple as our designs. By following the step-by-step instructions, preparing a door to fit our components should be easy as one two three. Keep in mind that the space for milling is always larger than the system itself.

System One 70 mm

Milling - preparing the door

Pivot point = minimally 70 mm

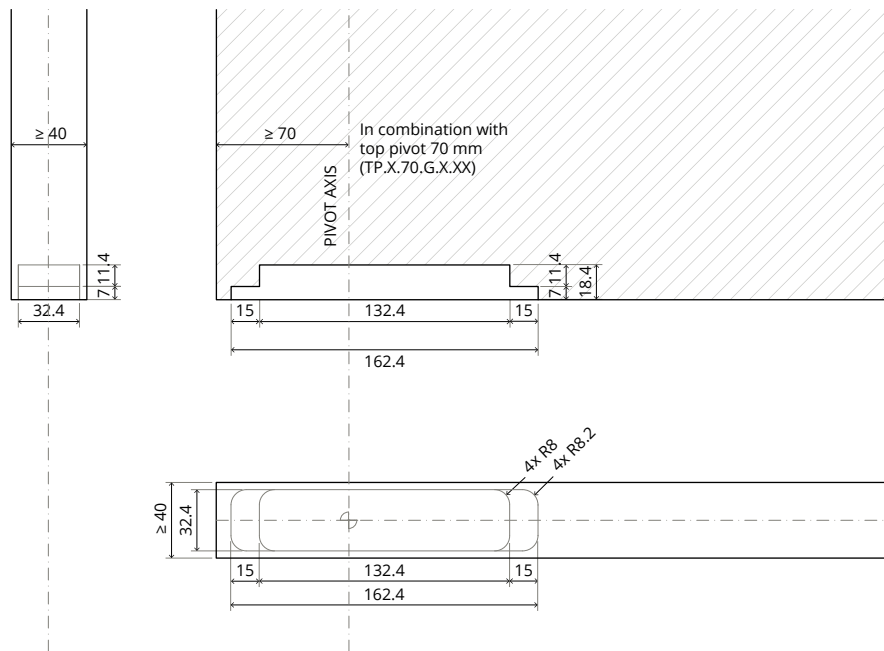

Components

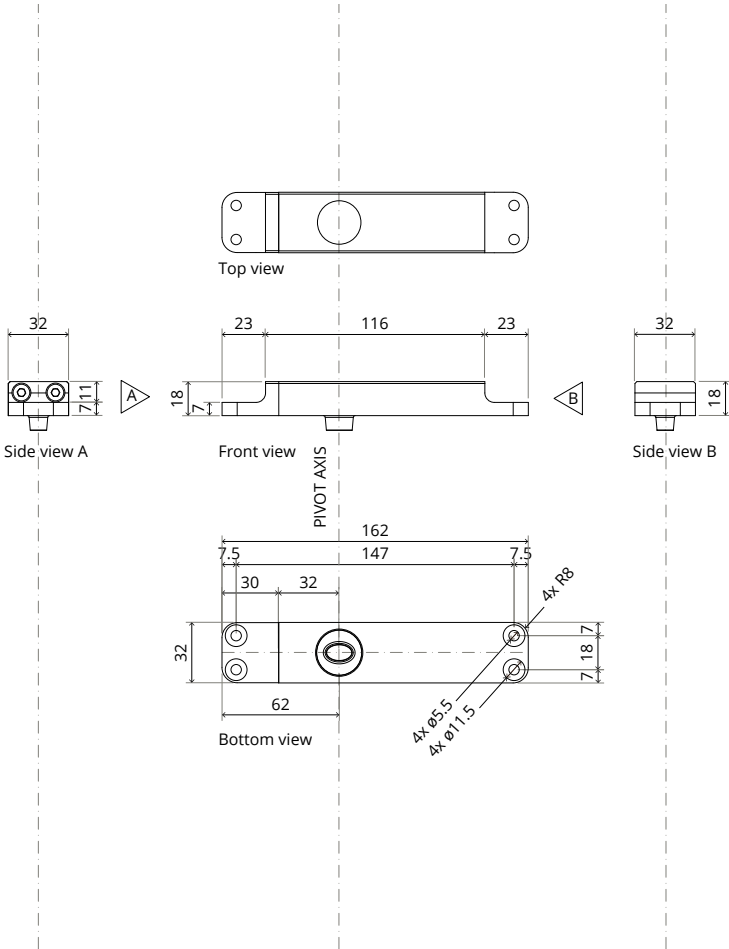

System One 40 mm

Milling - preparing the door

Pivot point = fixed 40 mm

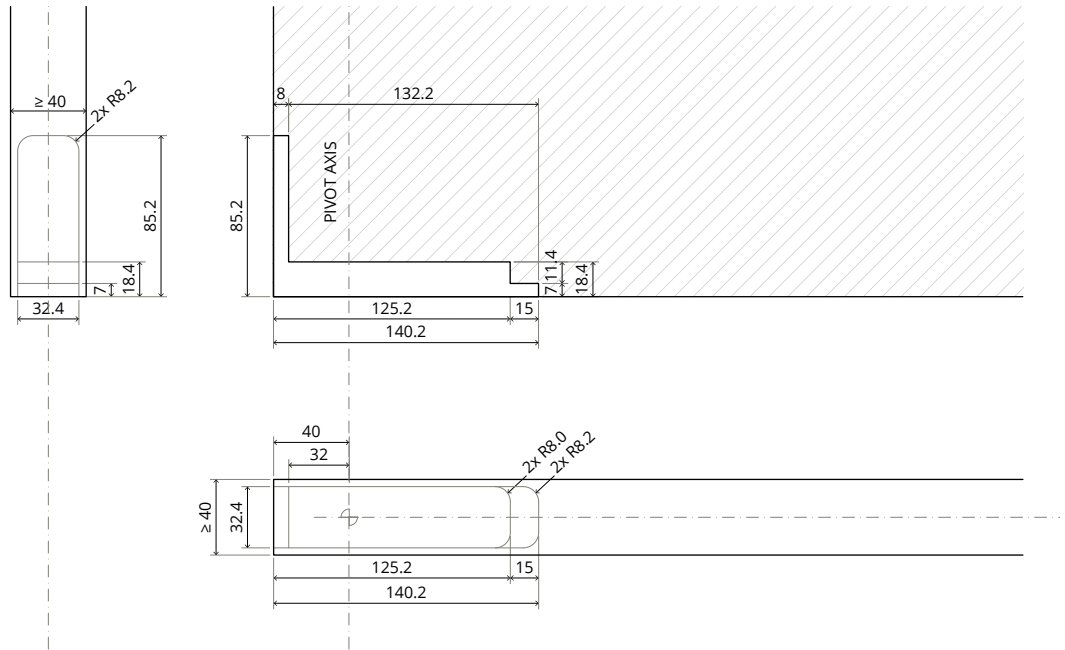

Top pivot 70 mm Class G

Milling - preparing the door

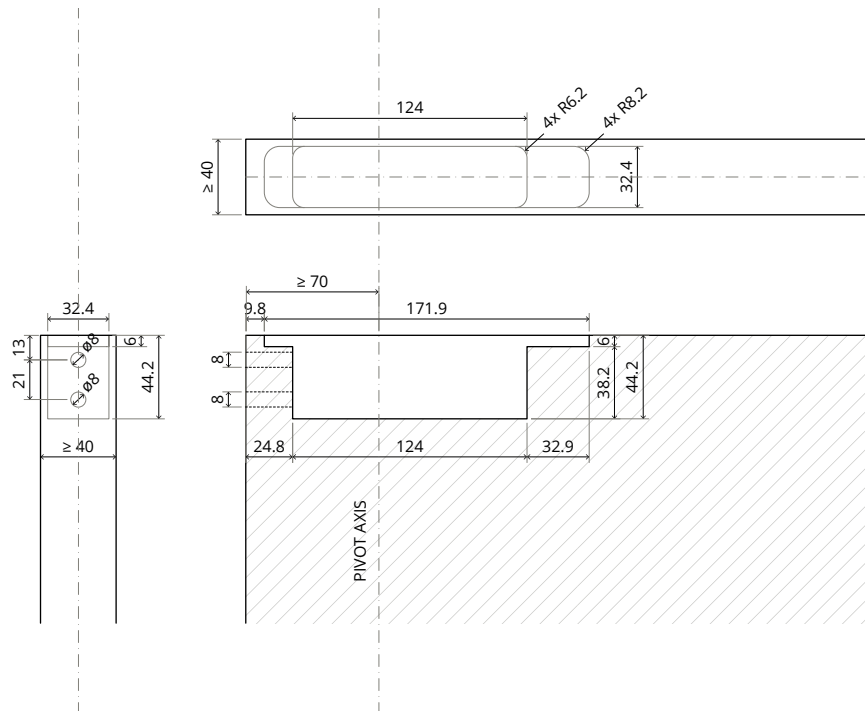

Components

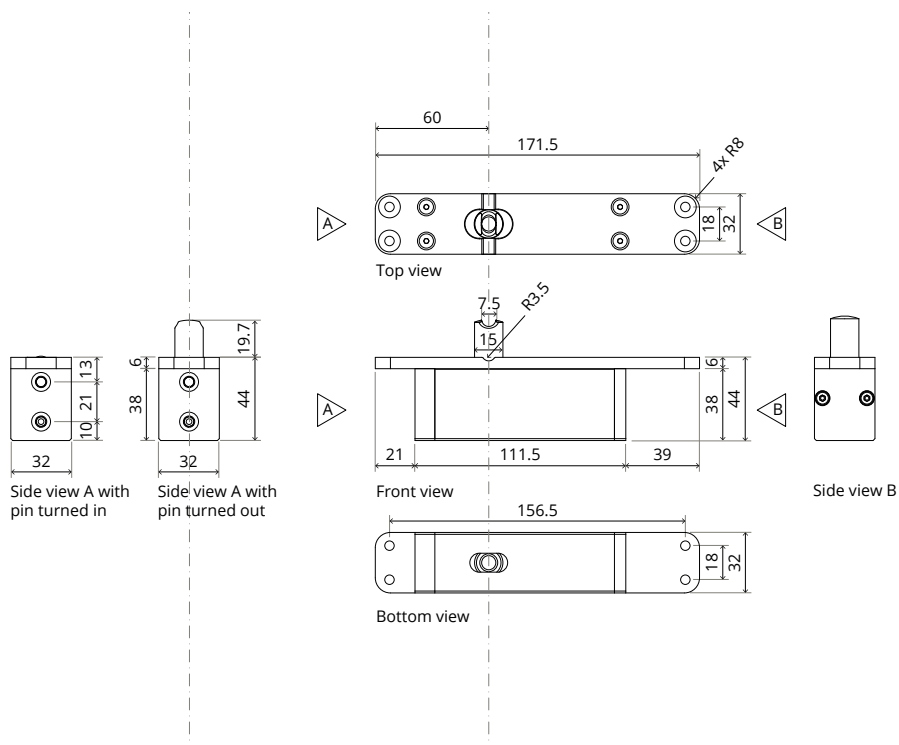

Top pivot 40 mm Class G

Milling - preparing the door

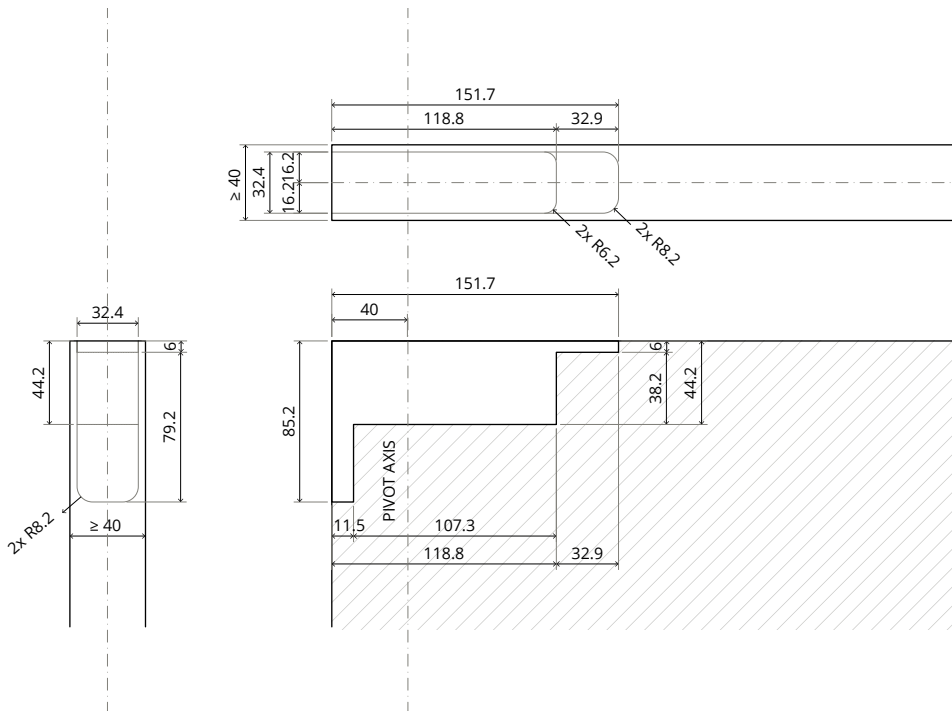

Components

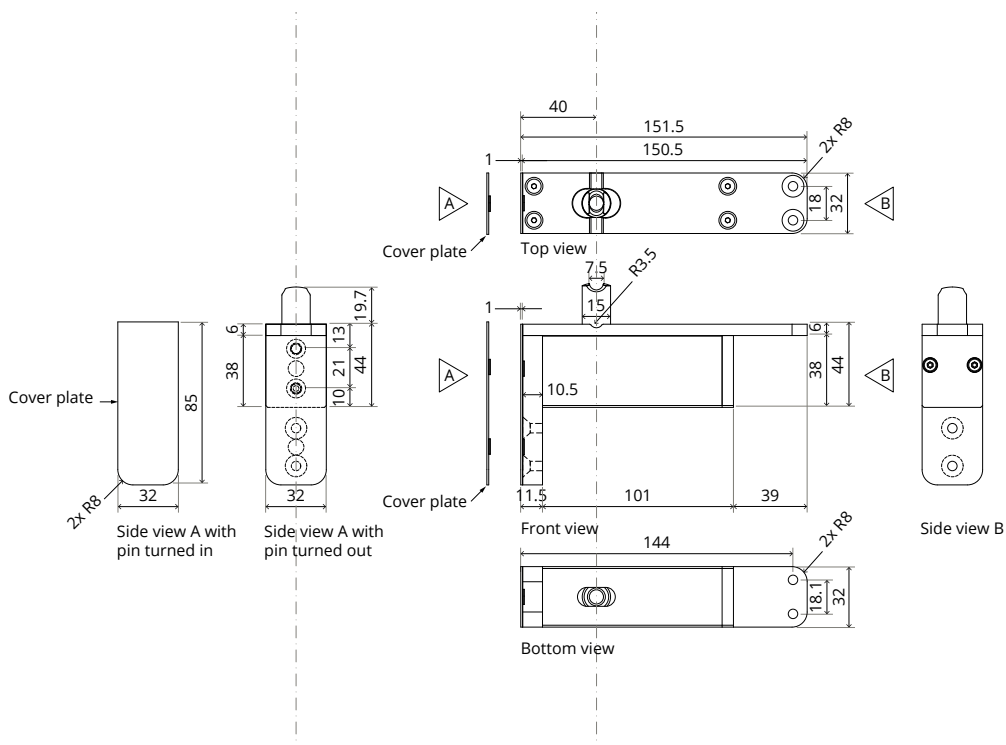

Top pivot Reversed

Milling - preparing the door and ceiling/head jamb

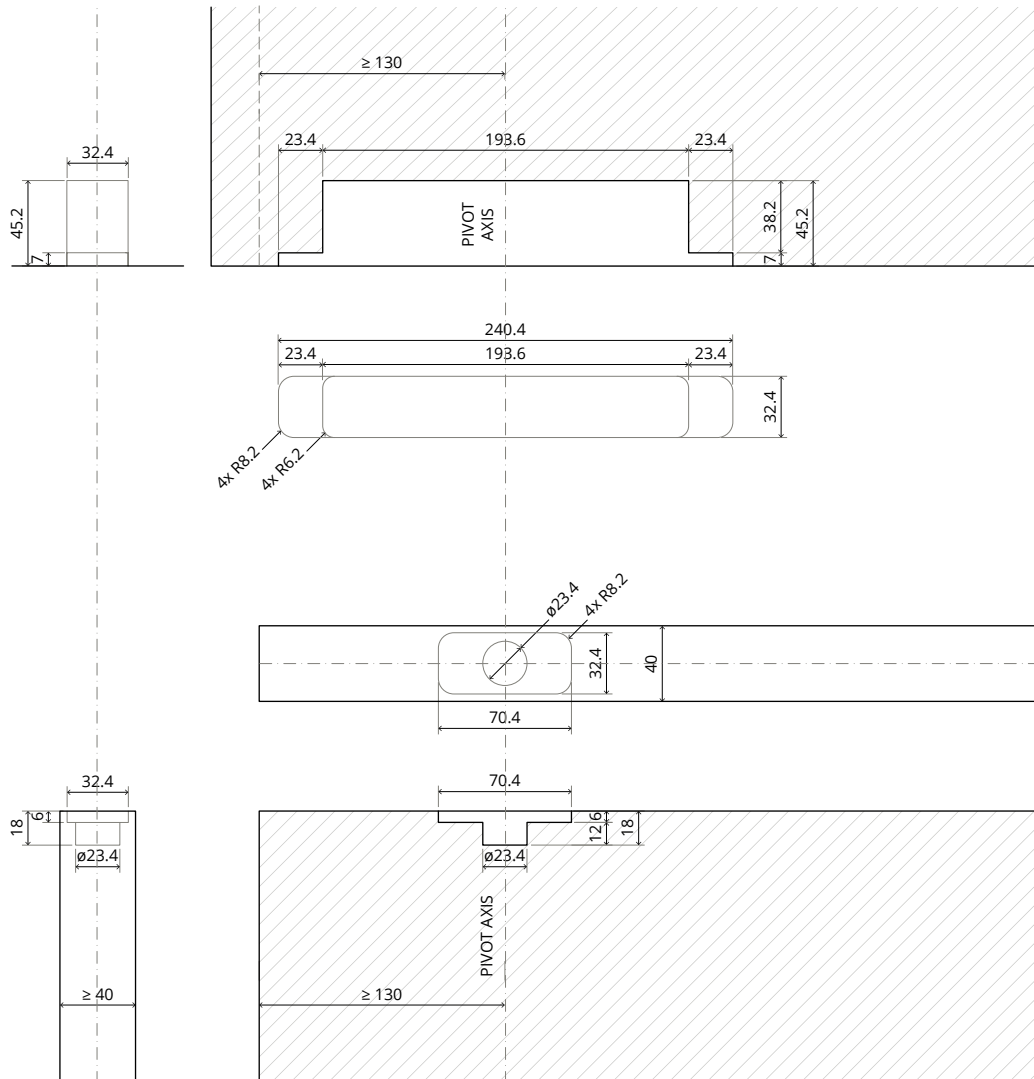

Components

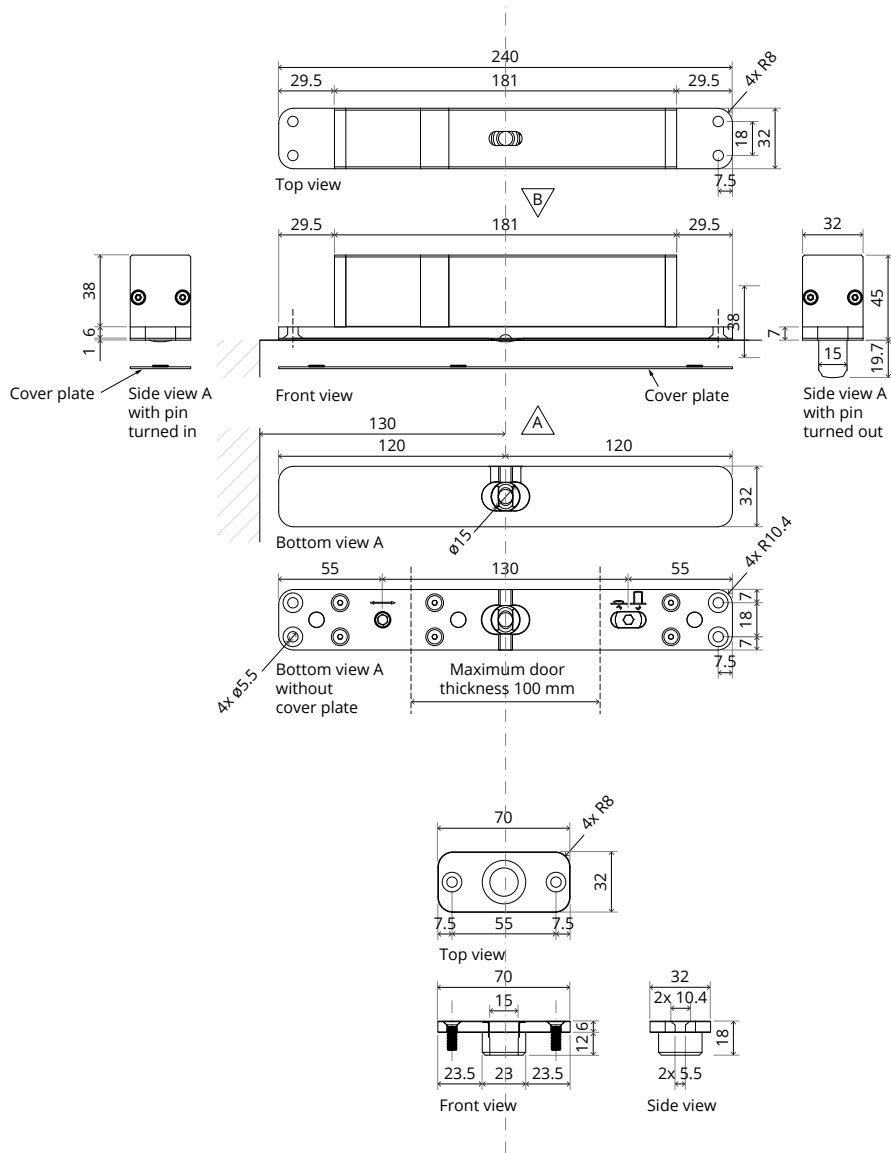

FritsJurgens International

A. Einsteinlaan 1
9615 TE Kolham
The Netherlands
+31 598 343 410
info@fritsjurgens.com

FritsJurgens Dubai Branch

DLC-OP-A2-4-0029
Dubai South
Dubai
United Arab Emirates
+971 4 820 8106
+971 58 137 2611
dubai@fritsjurgens.com

fritsjurgens.com



Copyright © FritsJurgens®
BO.tech.One.EN - 11/2024