

# System M+

## Manuale di fresatura e montaggio

FritsJurgens Kit - 40 mm Classe A - acciaio inox

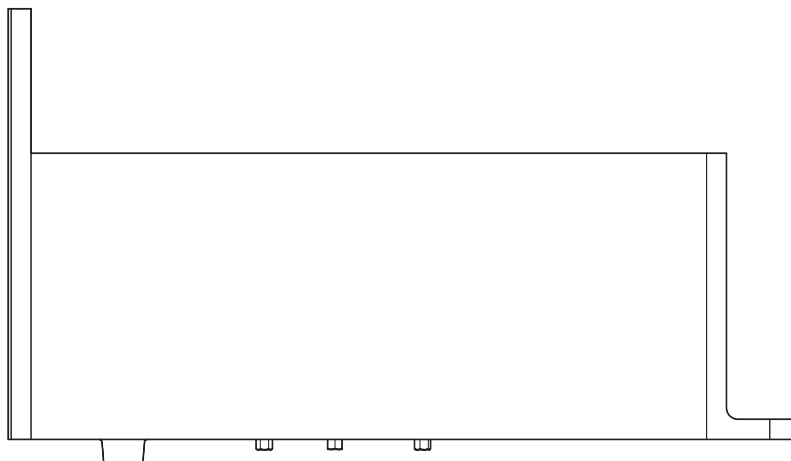

FritsJurgens®



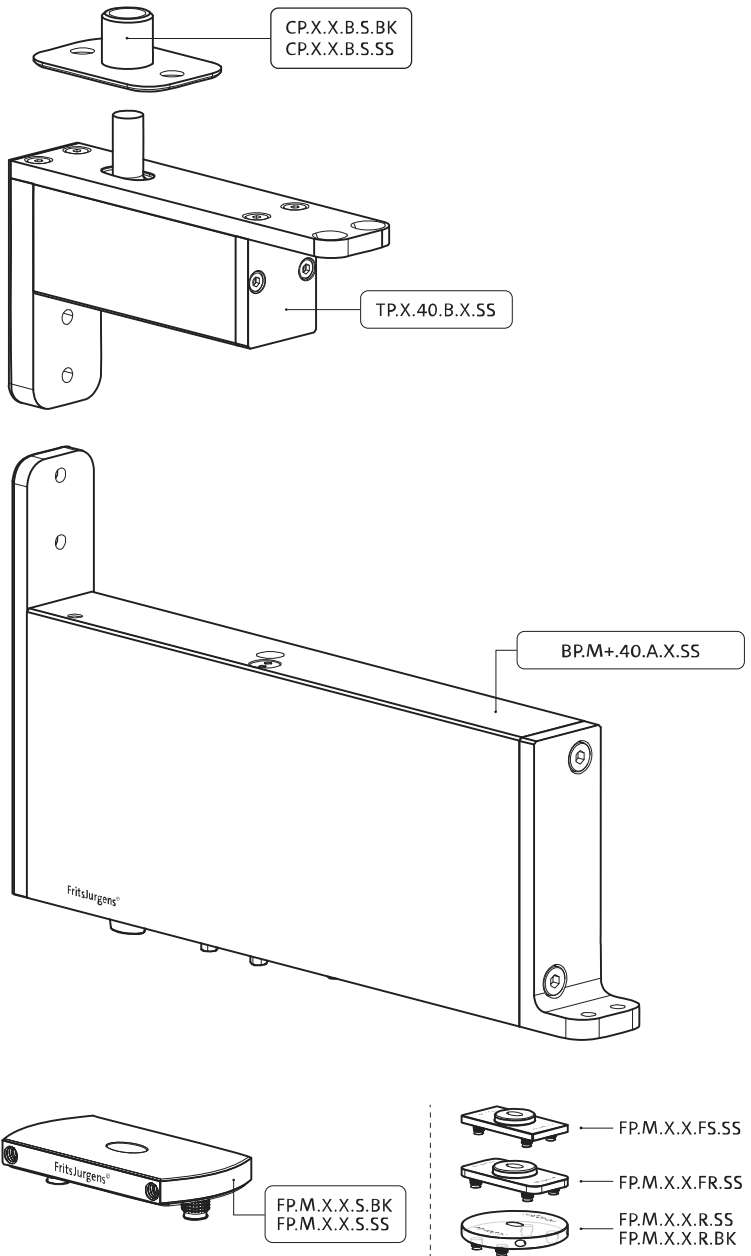



# Istruzioni di fresatura

# BP.M+.40.A.X.SS

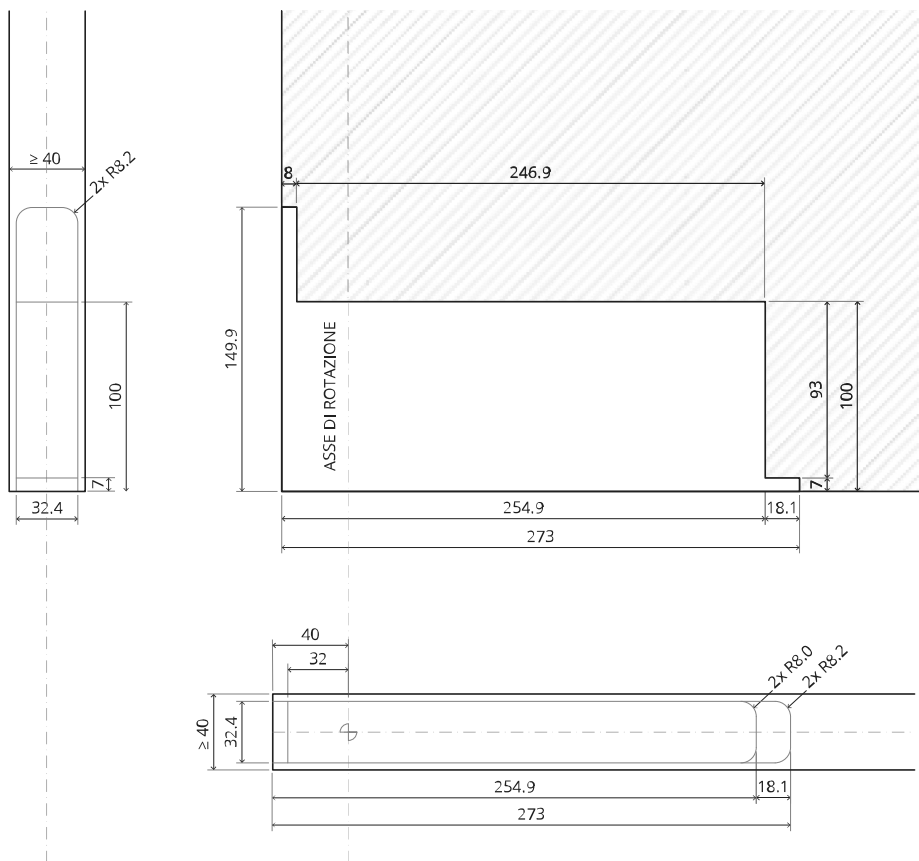

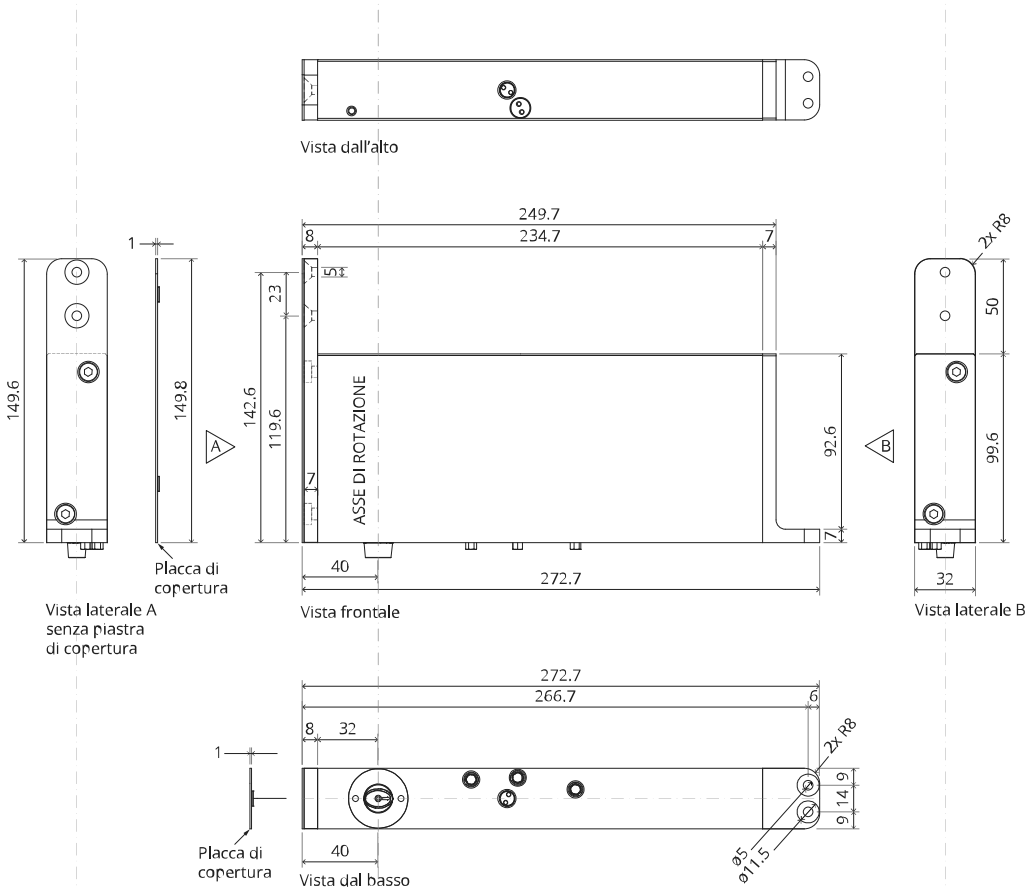

# TP.X.40.B.X.SS

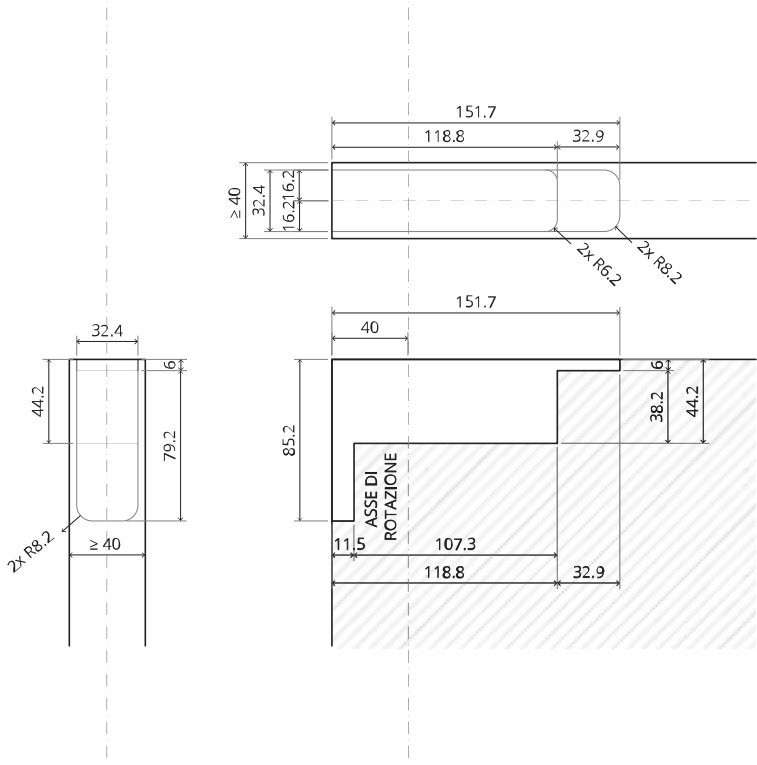



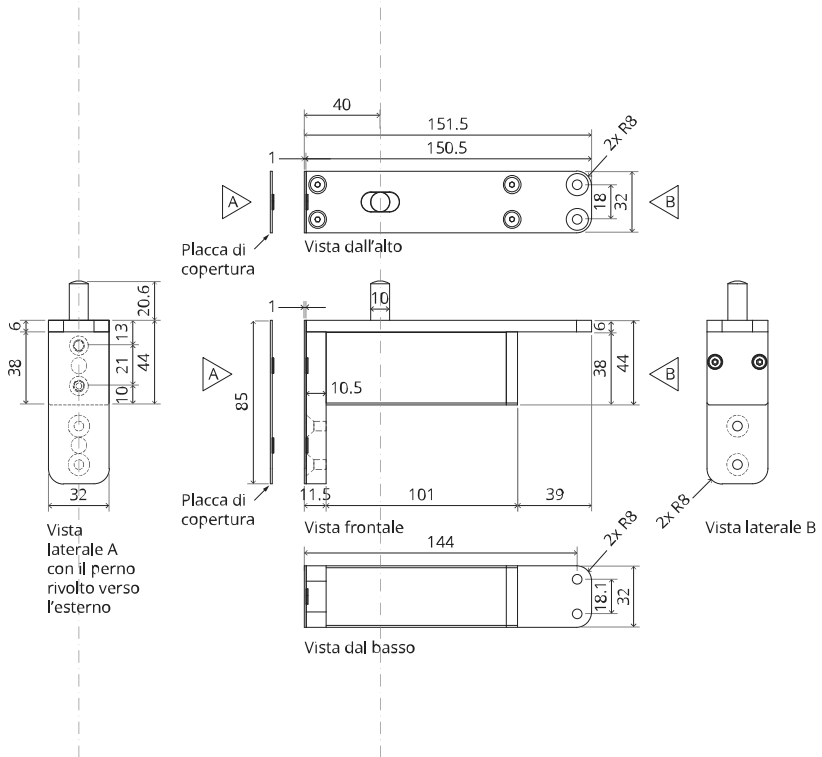

# FP.M.X.X.FS.SS

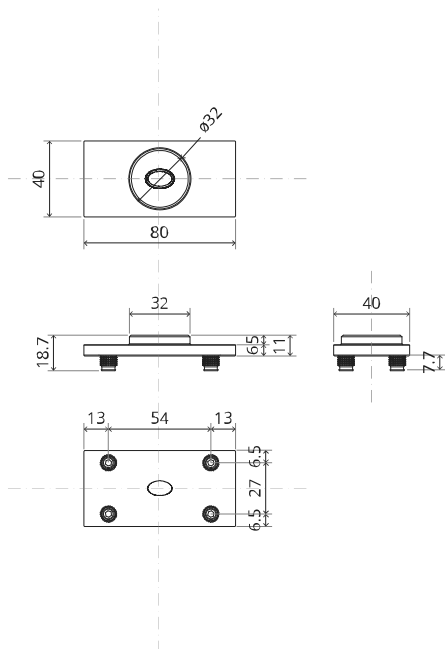
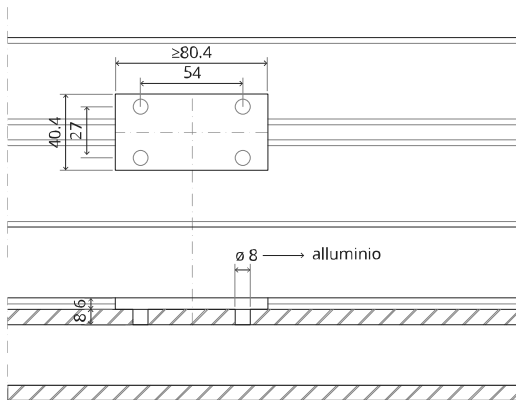

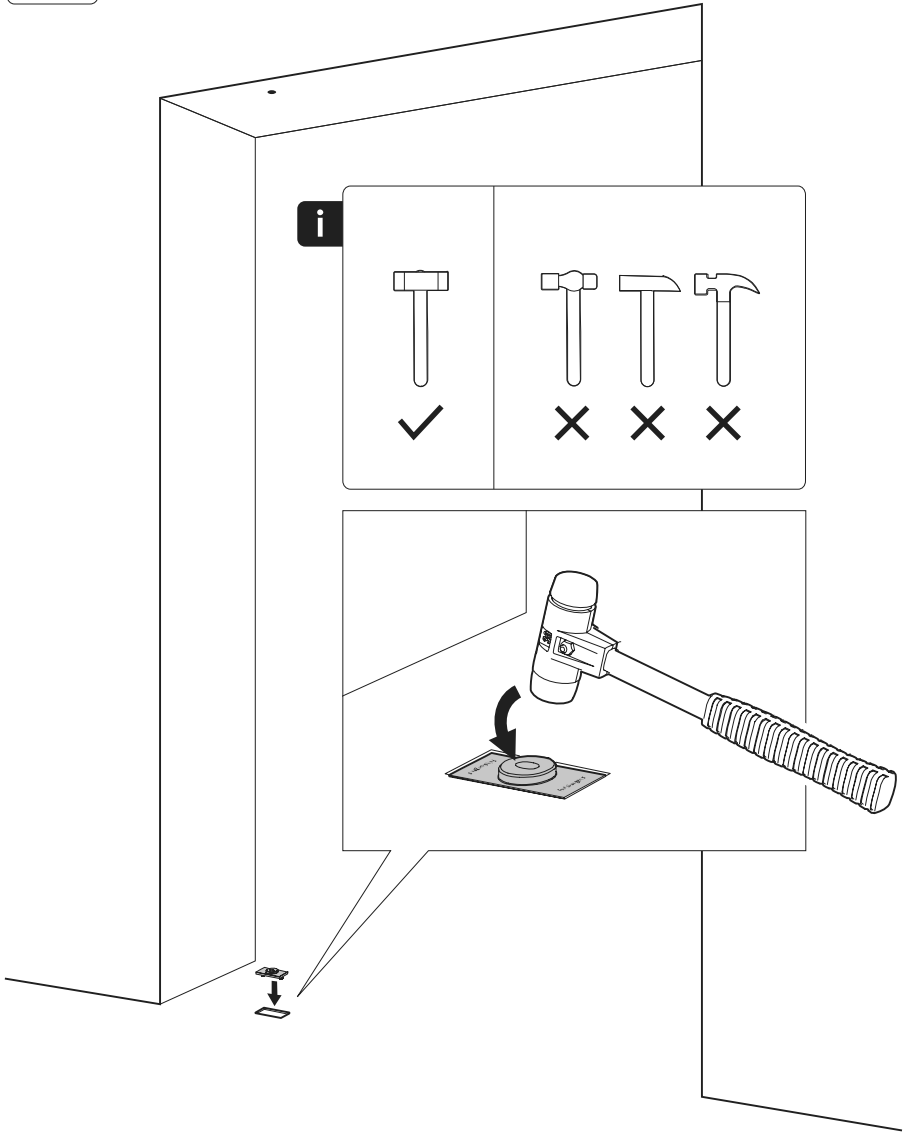

# FP.M.X.X.FR.SS

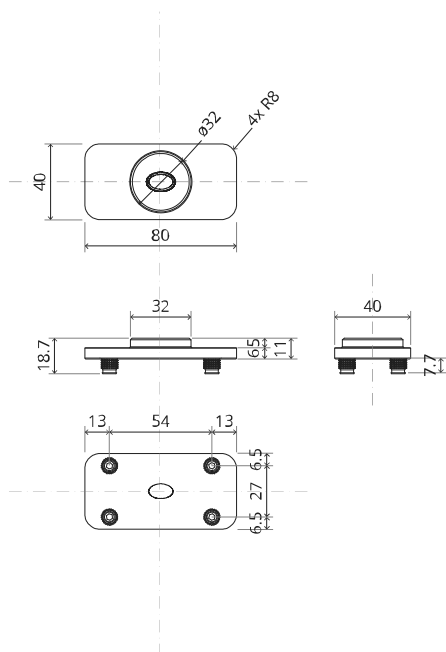
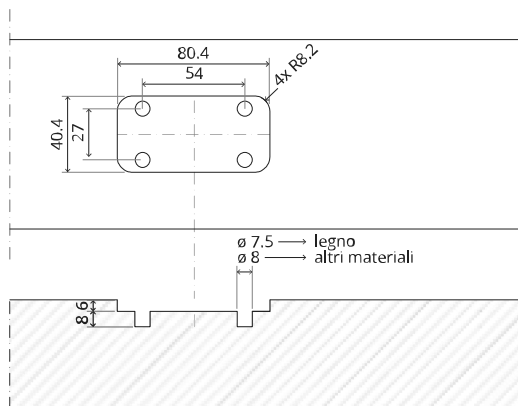

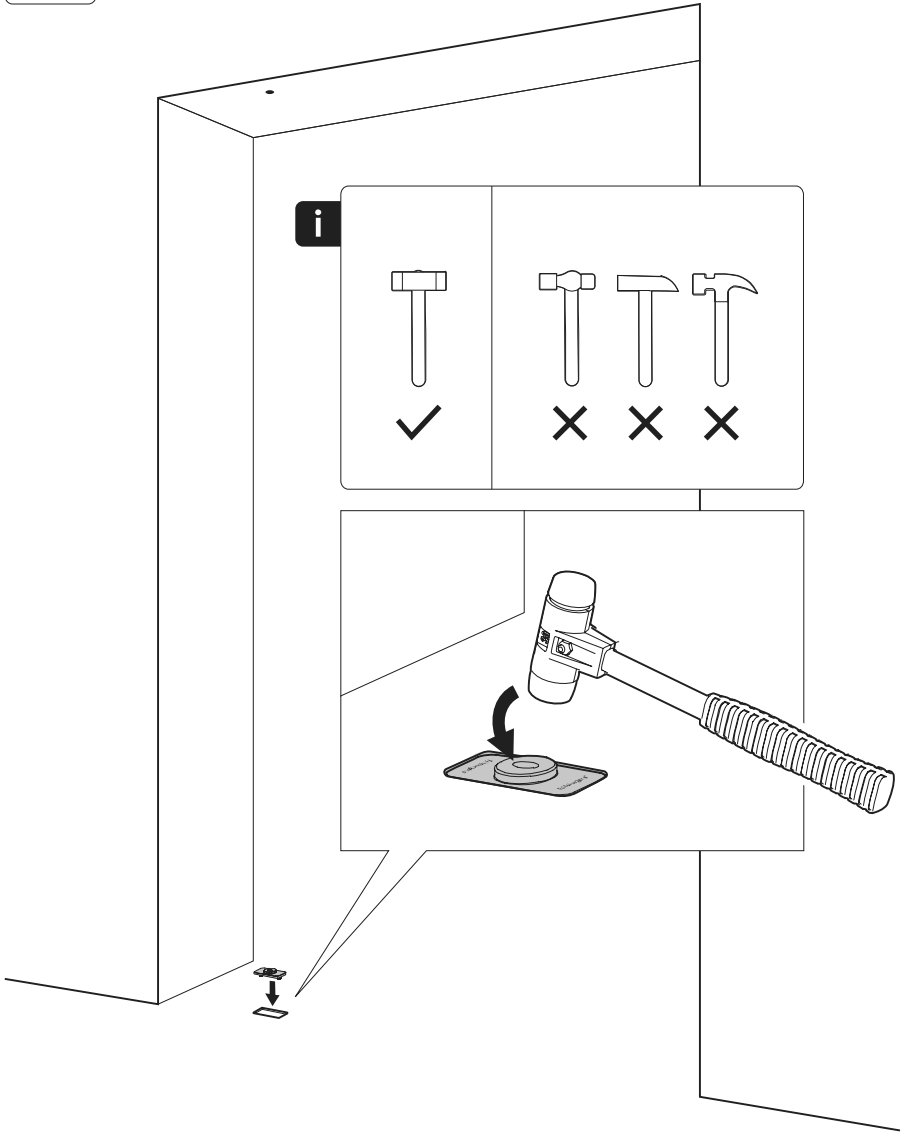



# Istruzioni di montaggio

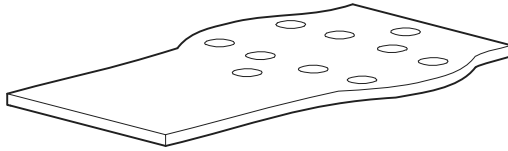

FJ.MT.DT.M

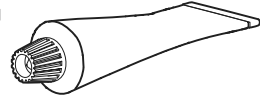

FJ.MT.Z5



10x FJ.Tx.4.0X50.PKDD



FJ.Bit.Tx20

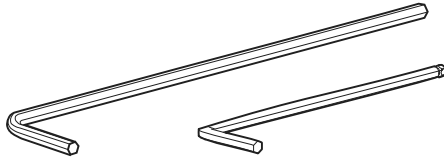

FJ.MT.AK3

FJ.MT.AK5x24

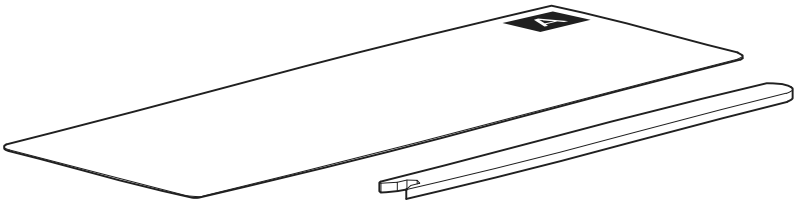

FJ.MT.AC.M+

FJ.MT.AS.M

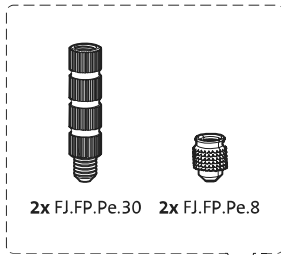

2x FJ.FP.Pe.30 2x FJ.FP.Pe.8

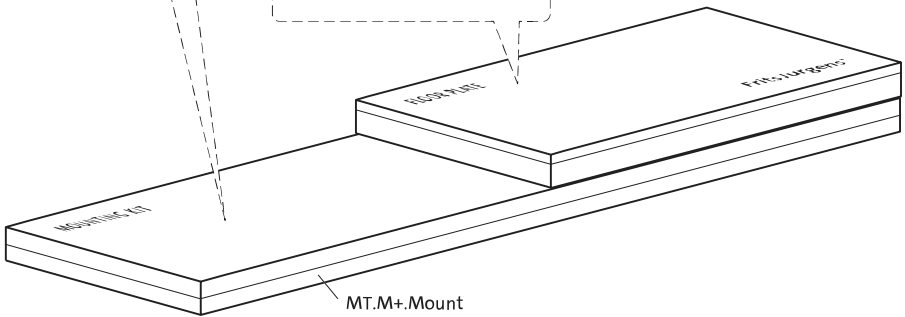

MT.M+.Mount



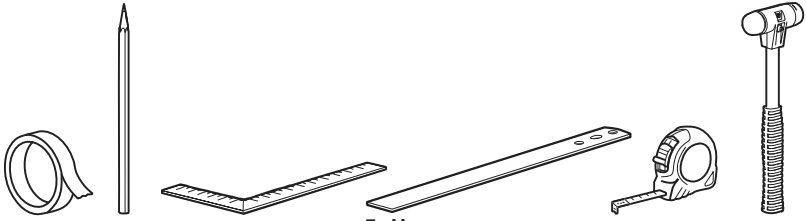

To.M

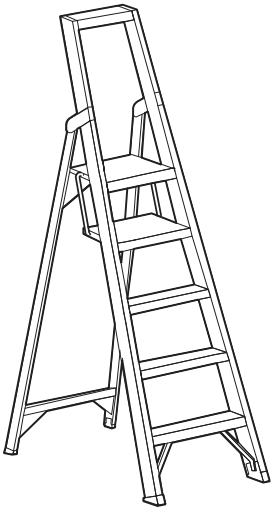
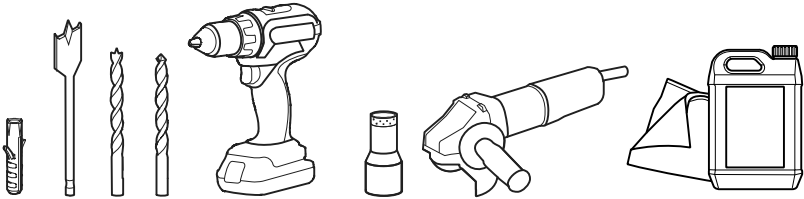

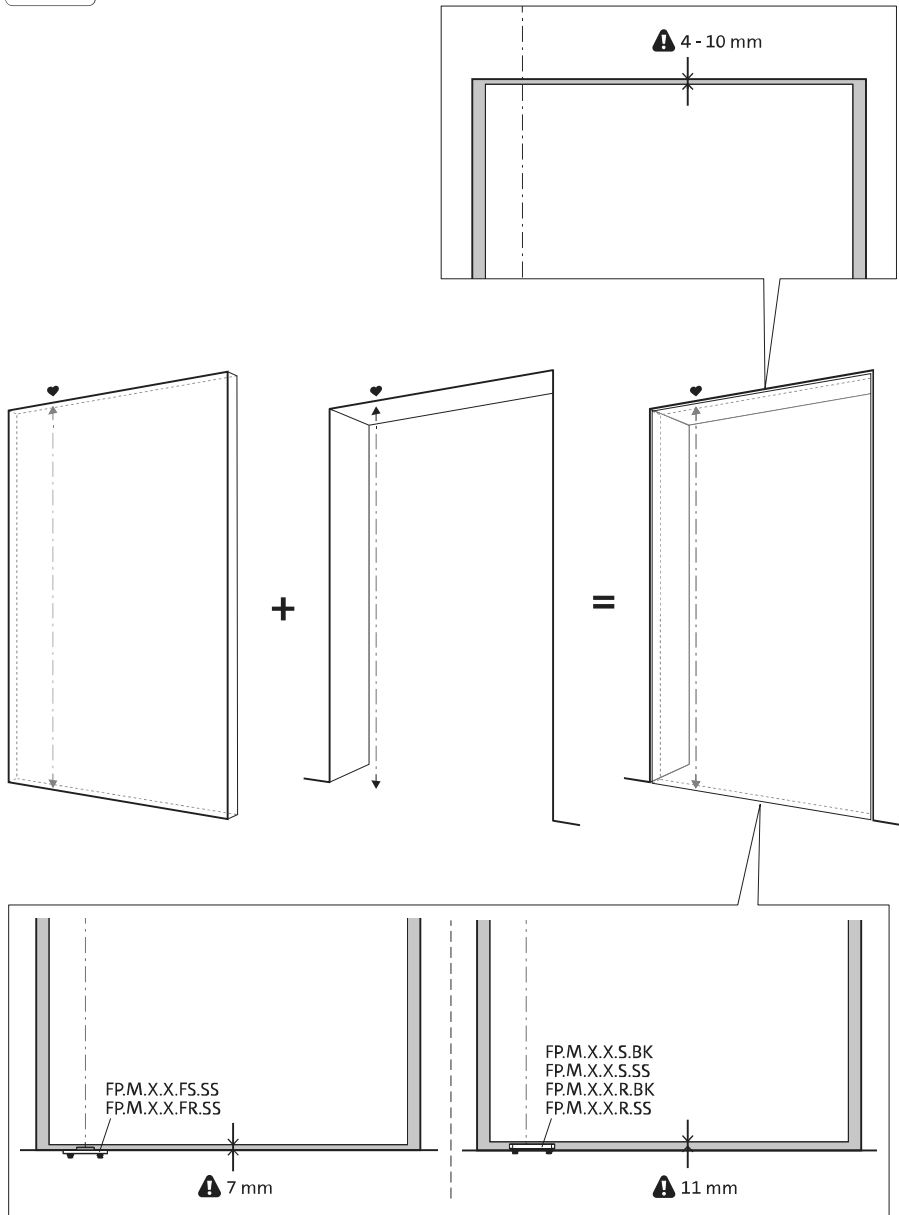



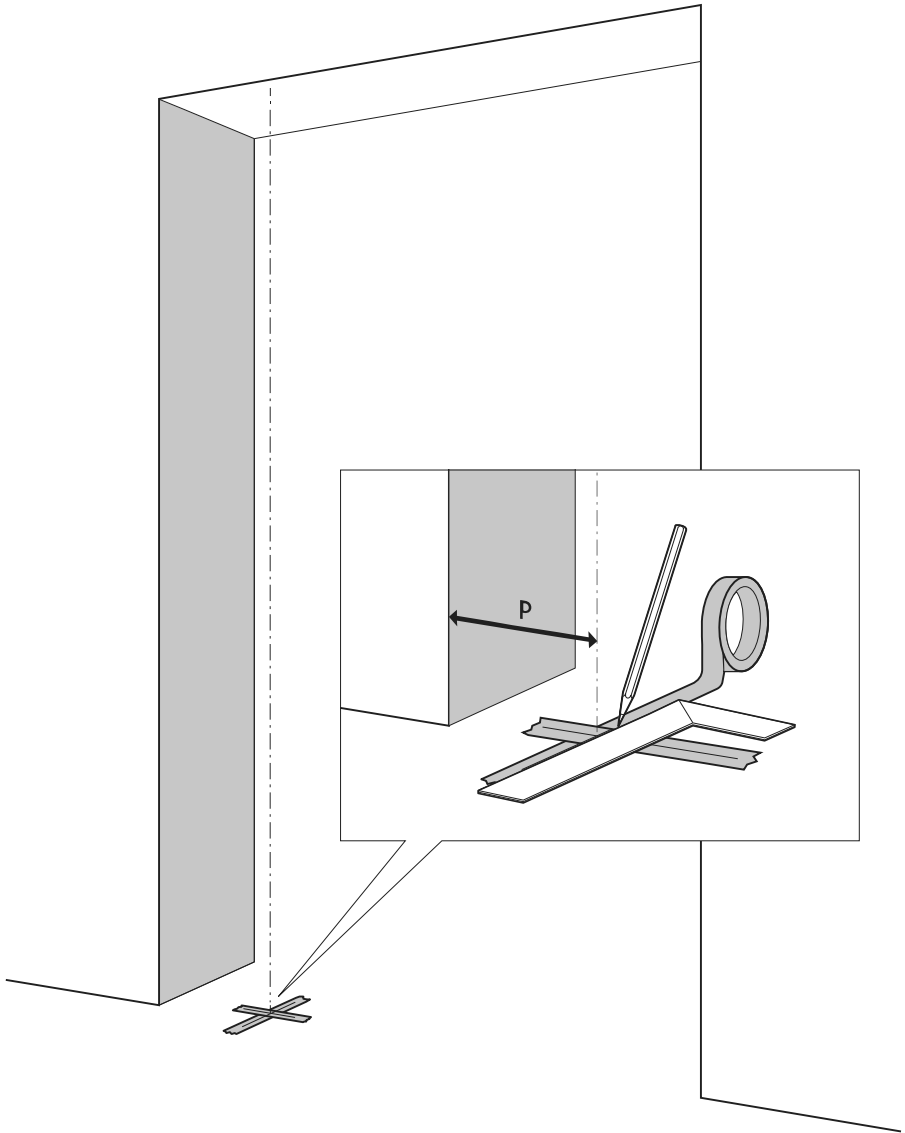

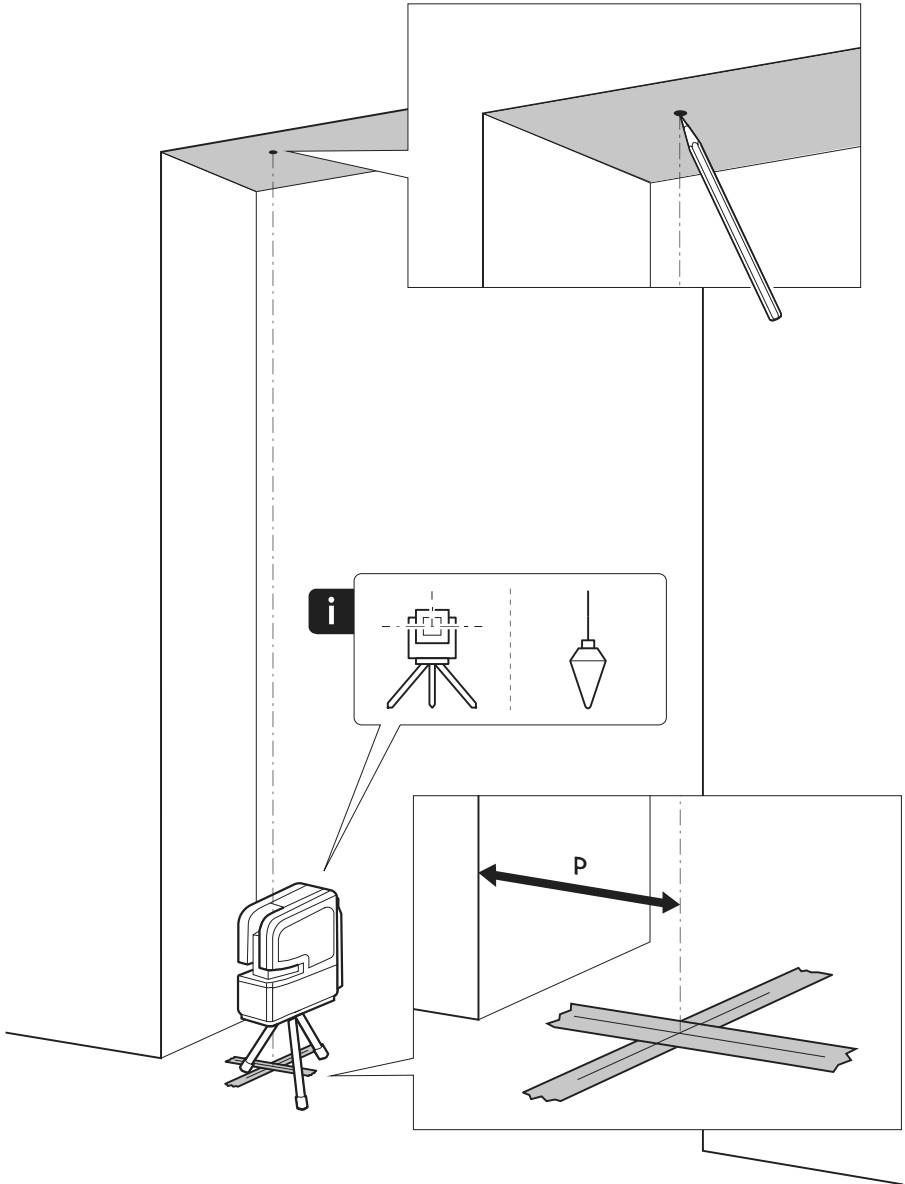

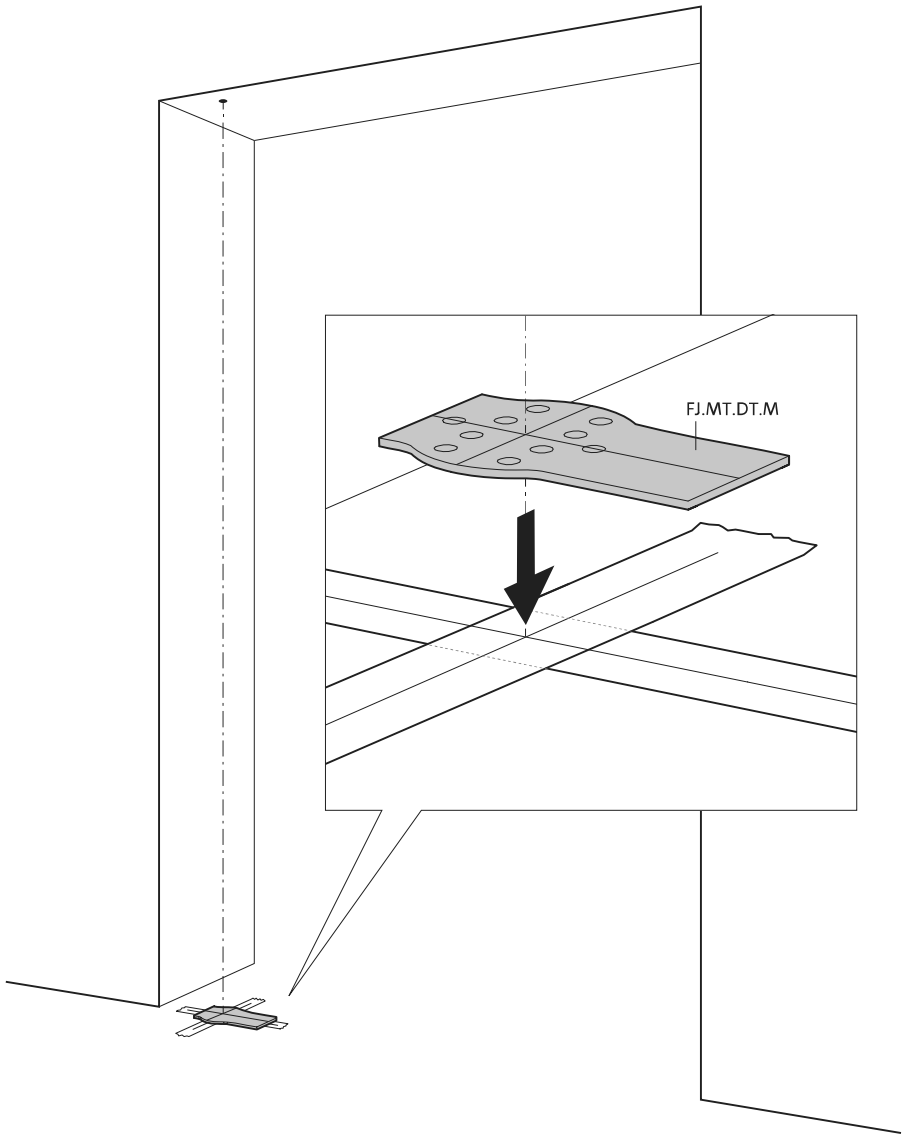

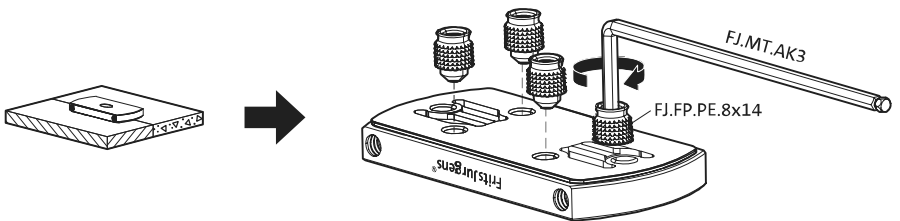
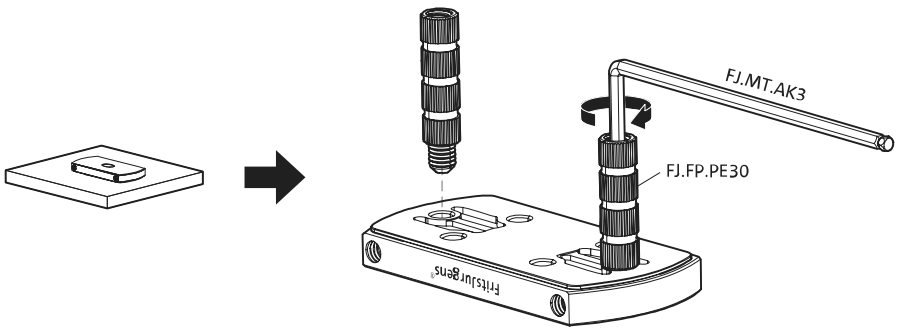
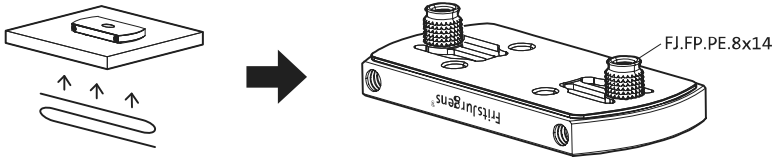



ø8 mm (5/16")

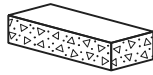
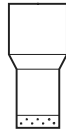

ø8 mm (5/16")

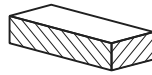

ø7.5 mm (19/64")

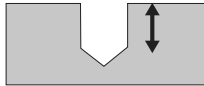

8 mm (5/16")

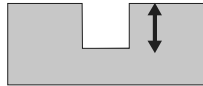

8 mm (5/16")

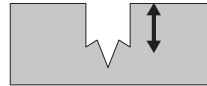

8 mm (5/16")

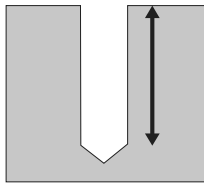
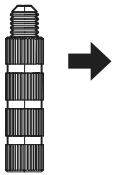

30 mm (13/16")

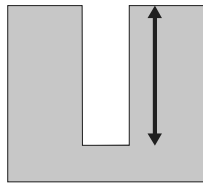

30 mm (13/16")

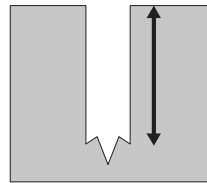

30 mm (13/16")



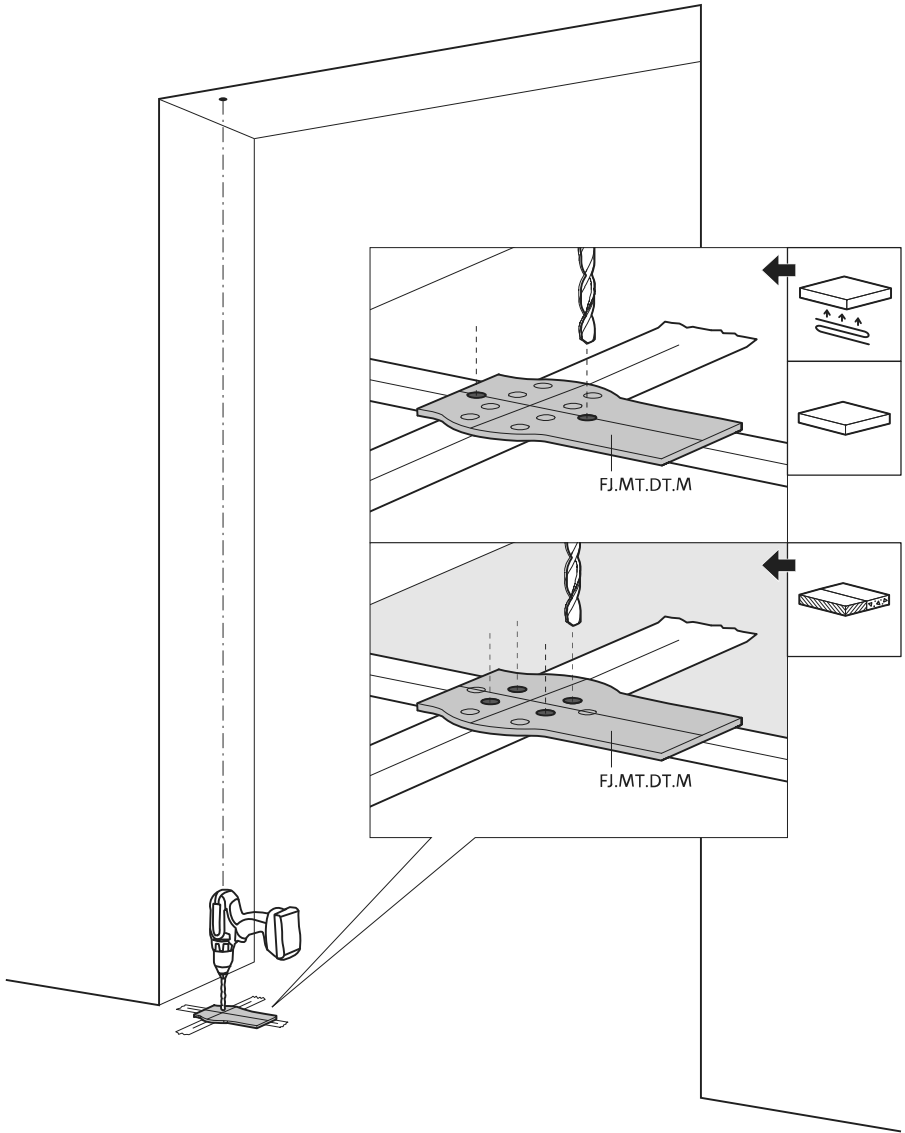

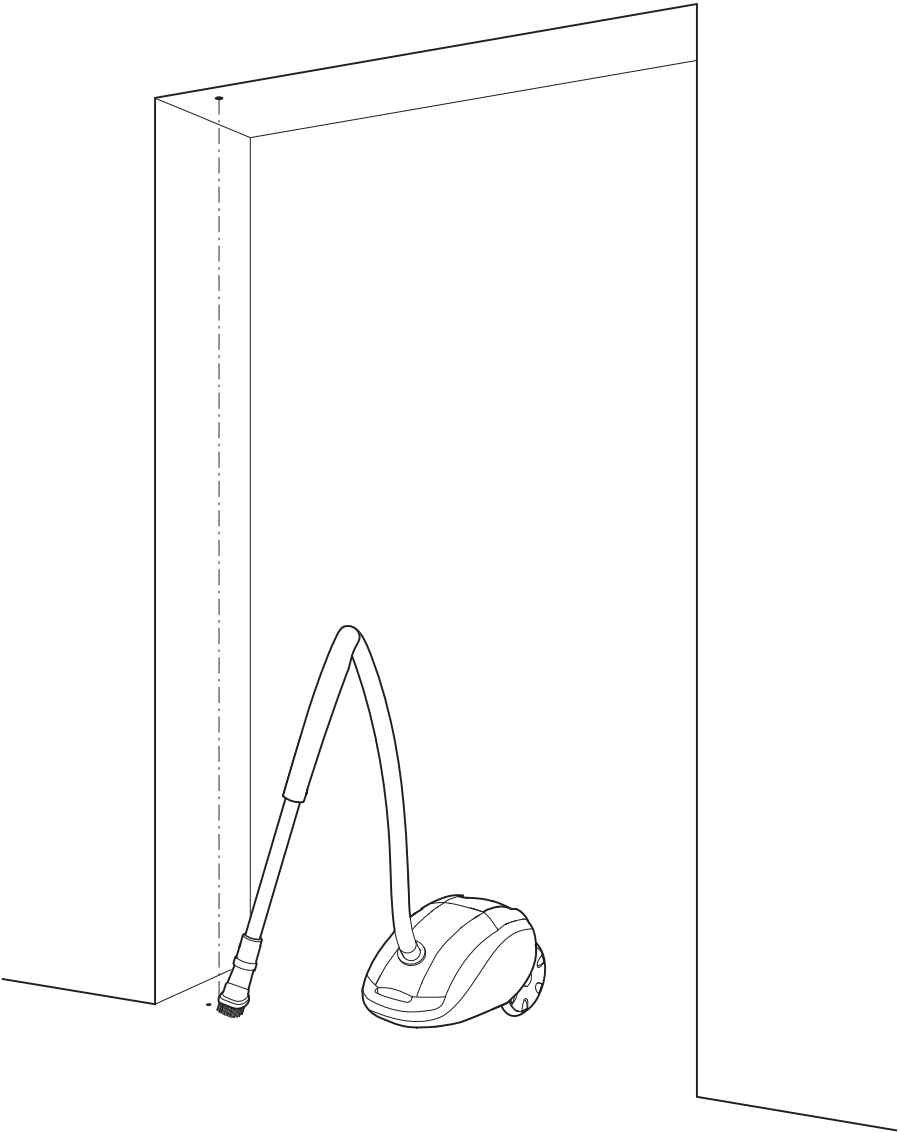



1

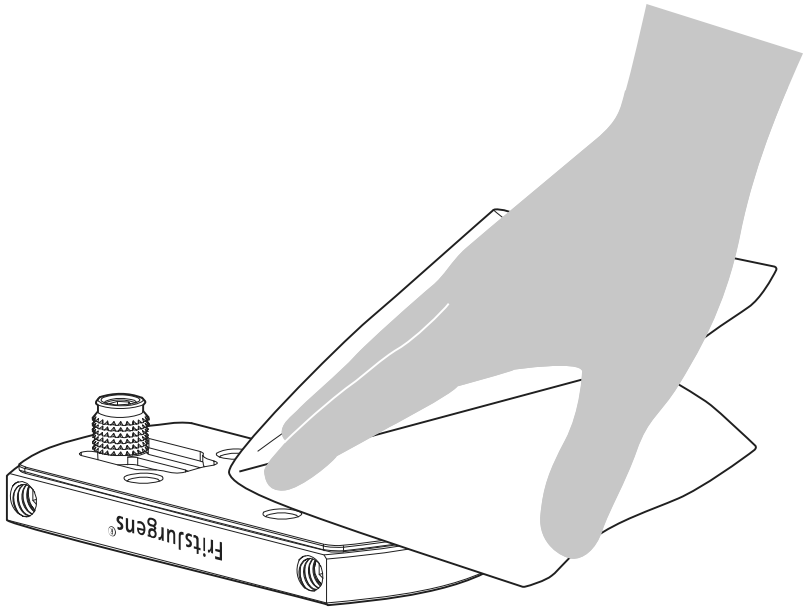

2

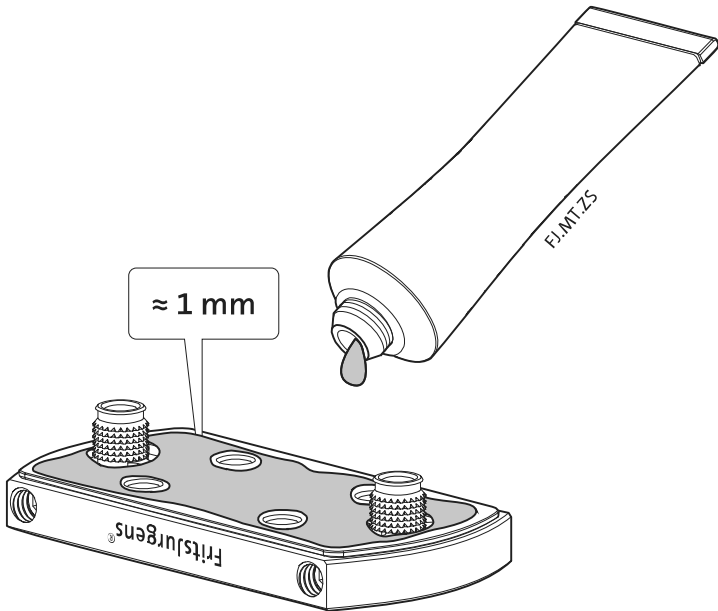

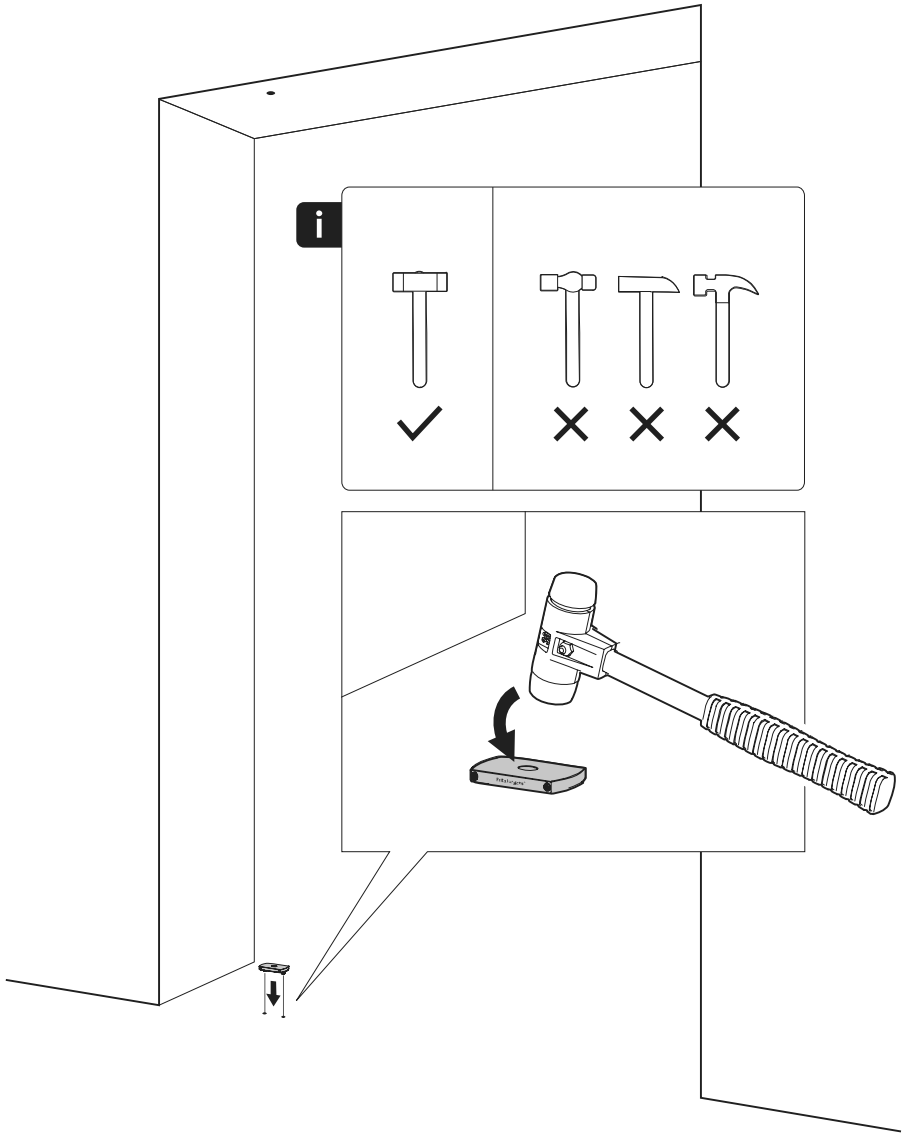

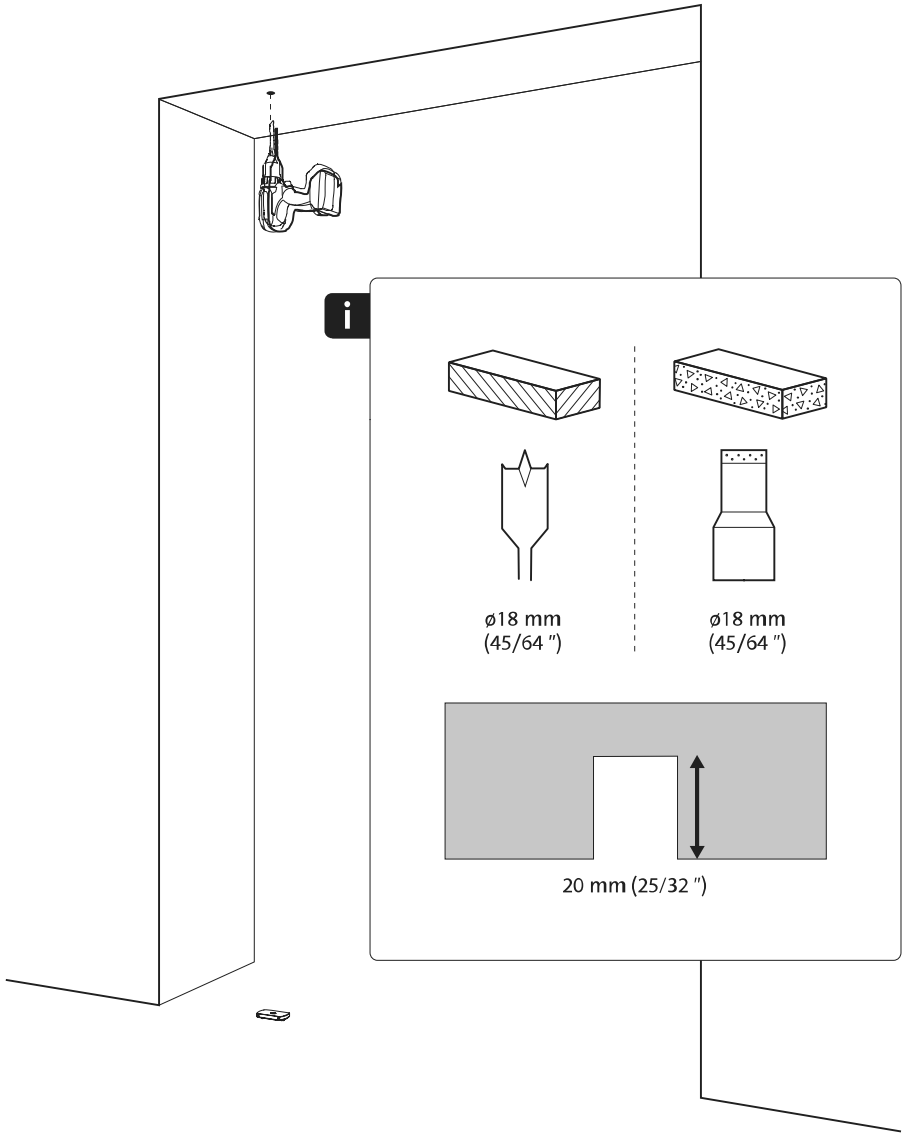



1

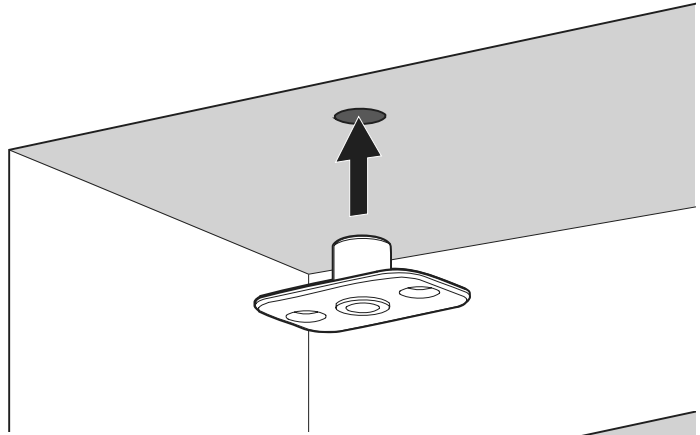

2

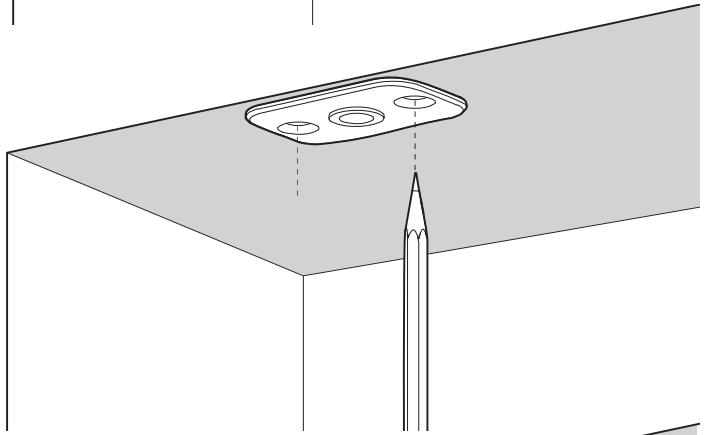

3

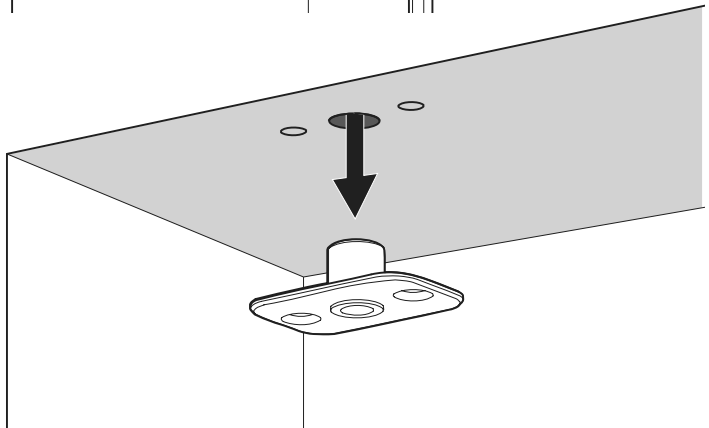



1

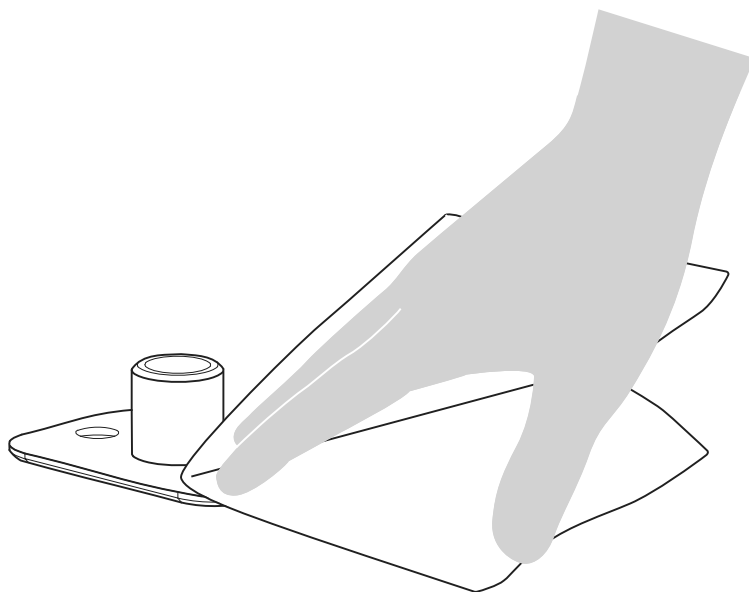

2

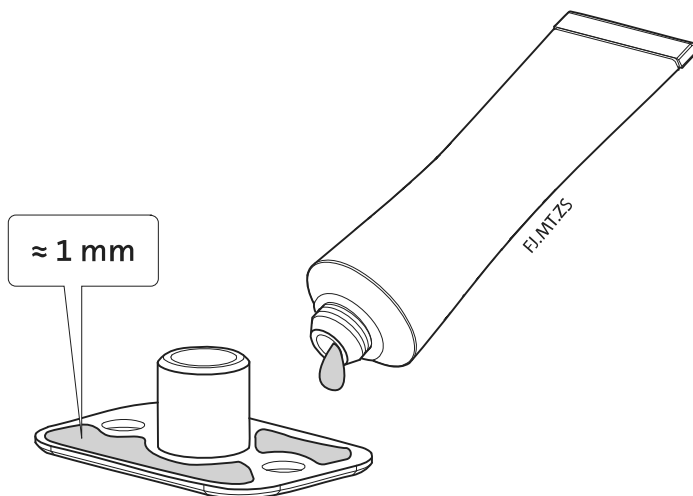

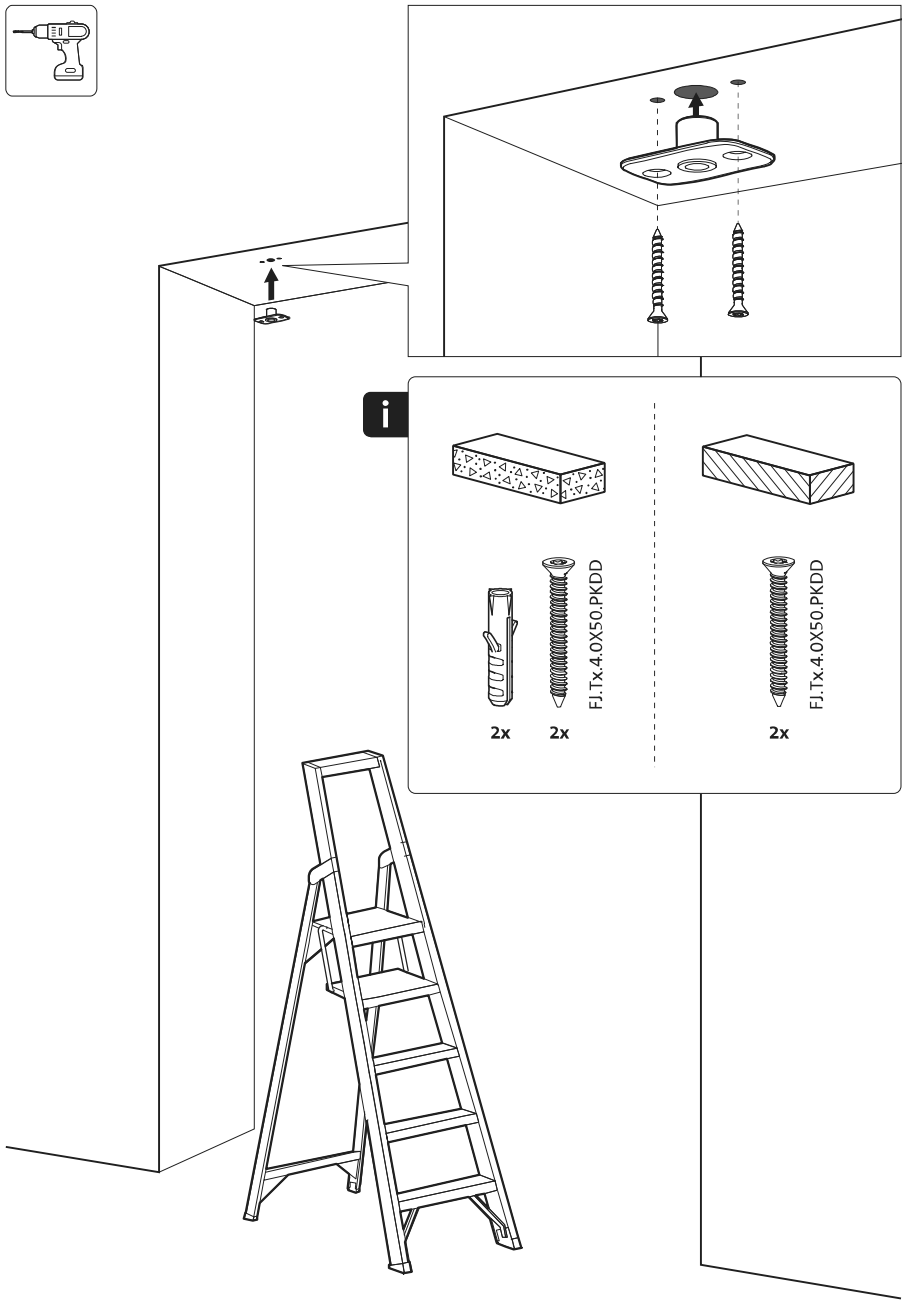



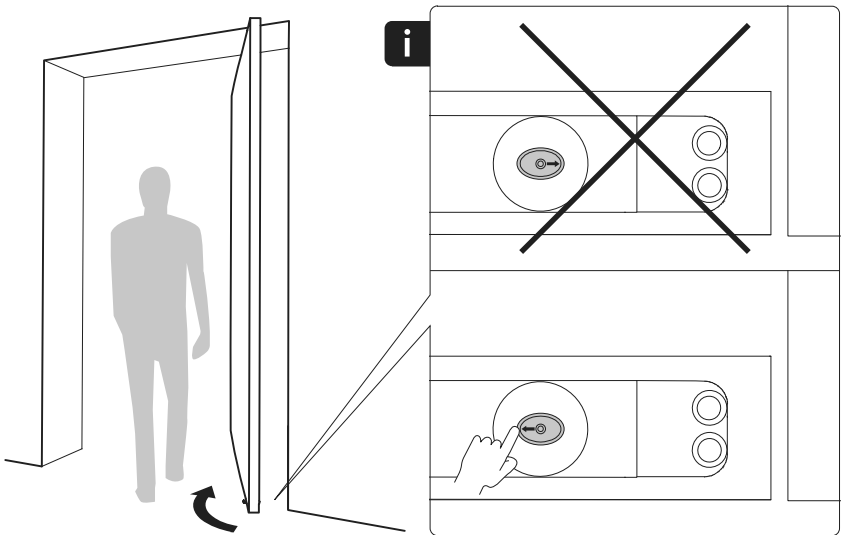
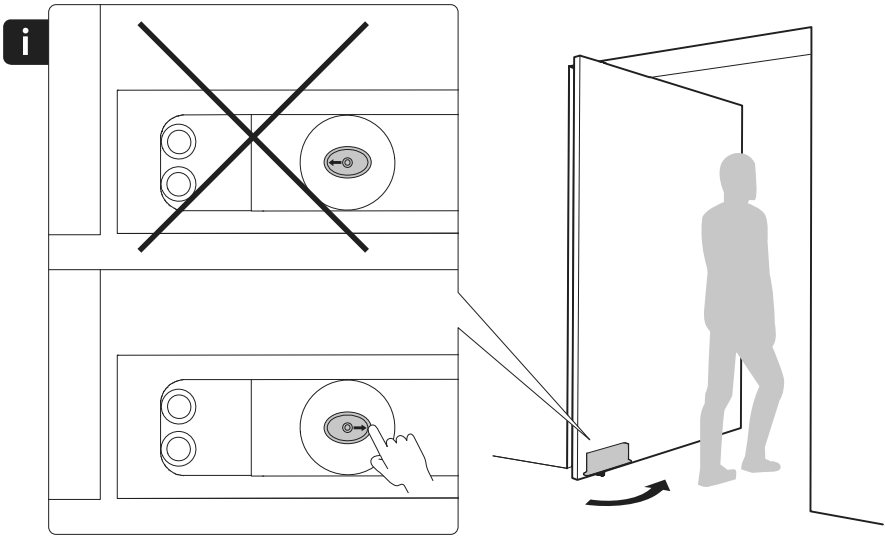

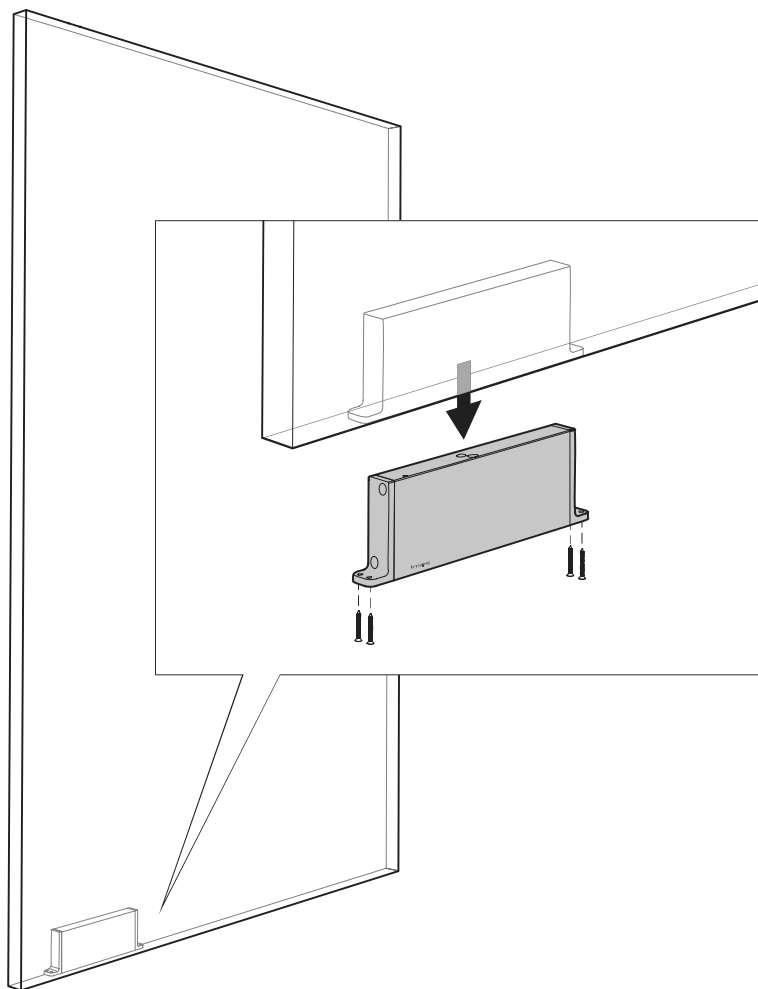

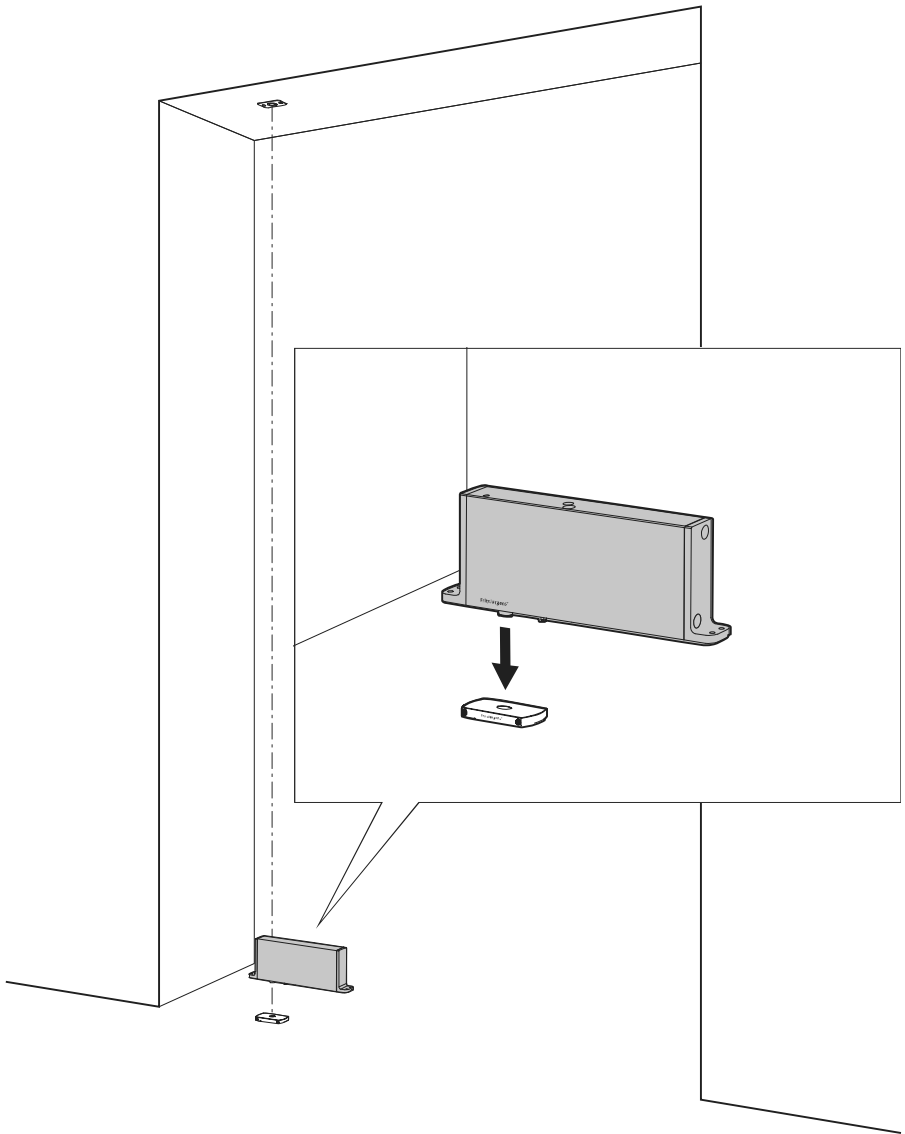

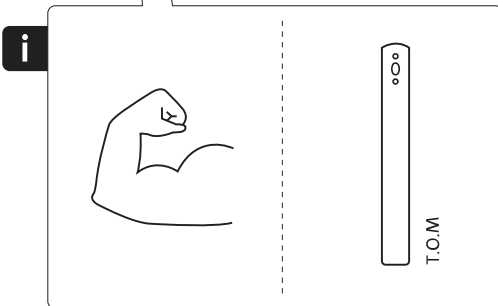
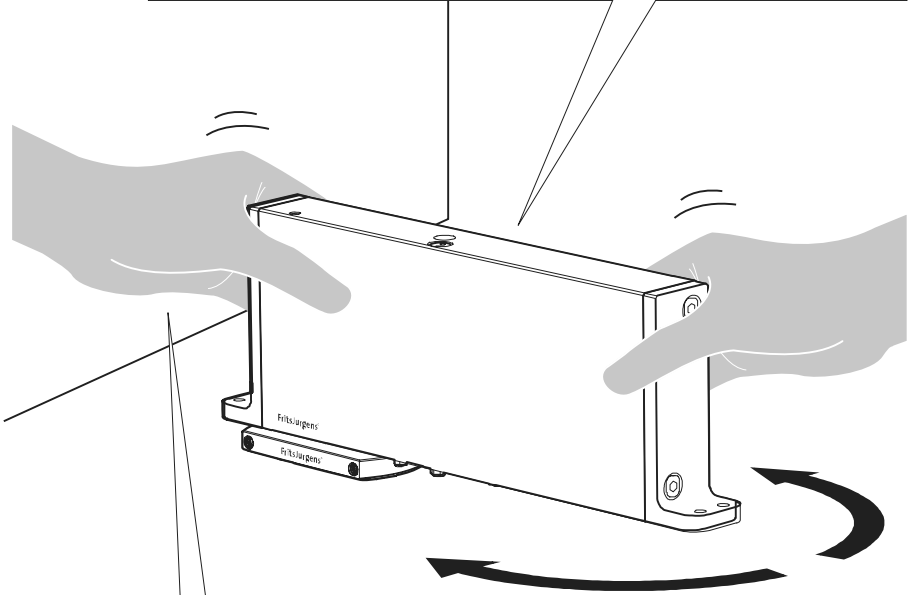
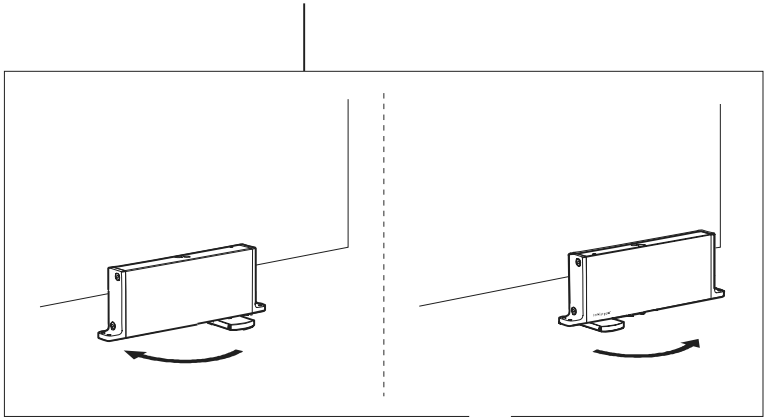

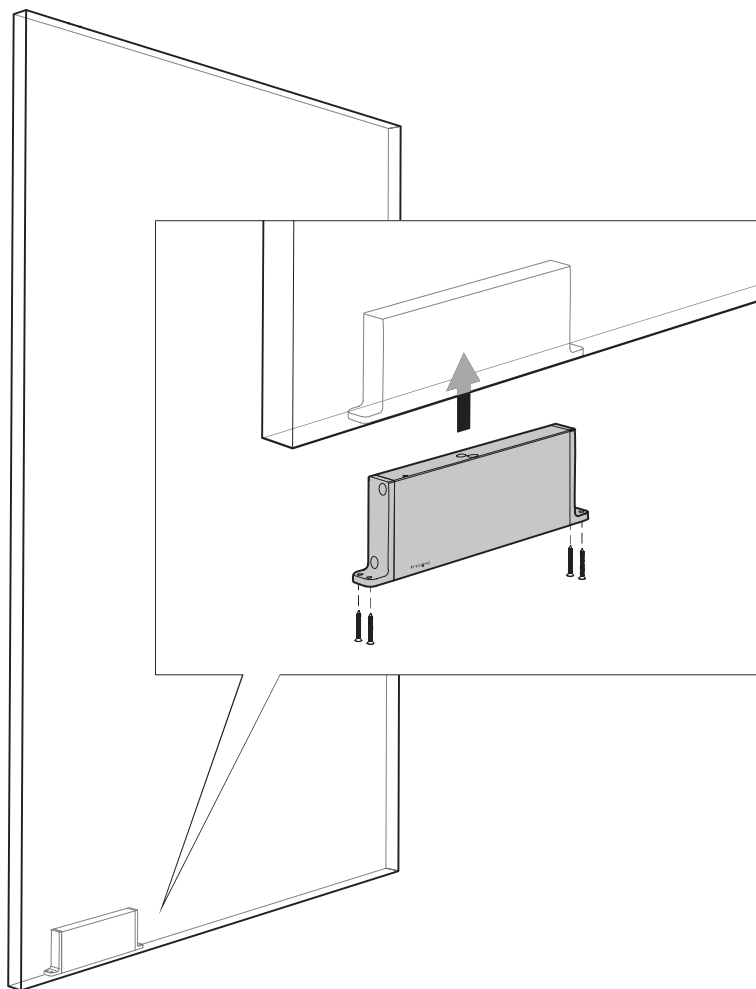

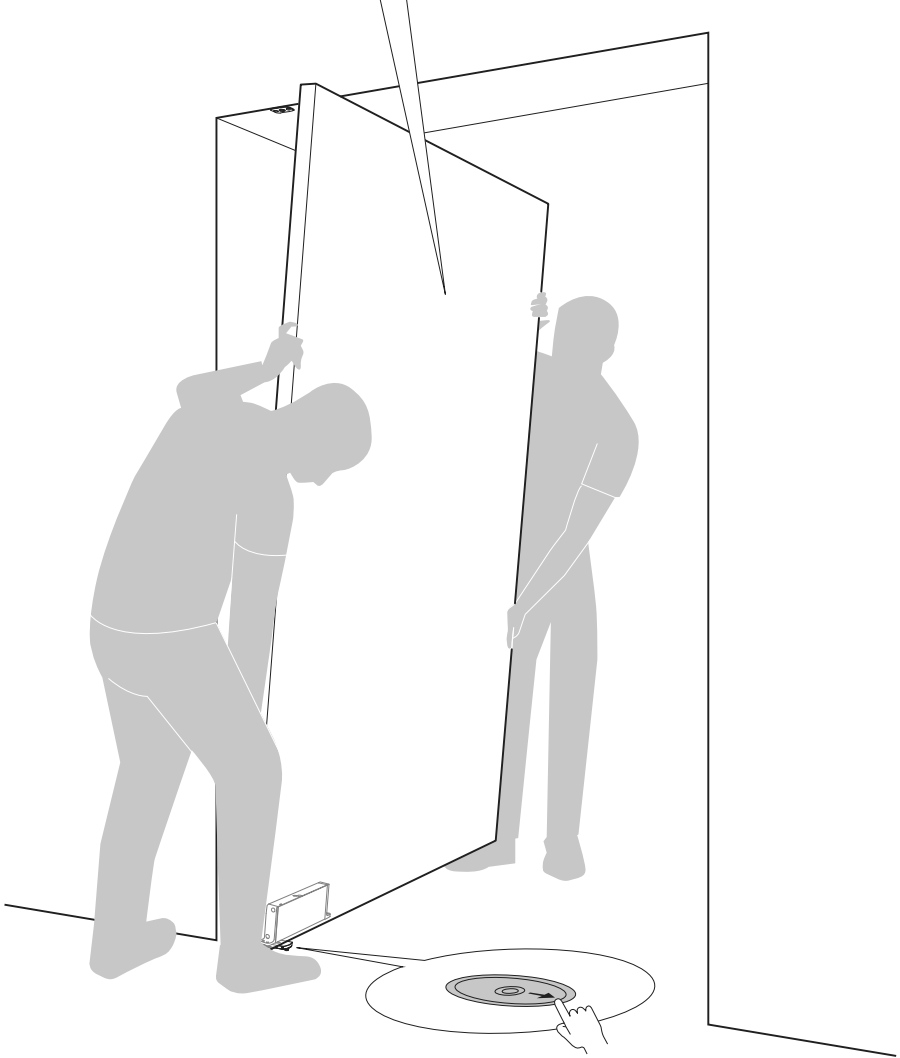
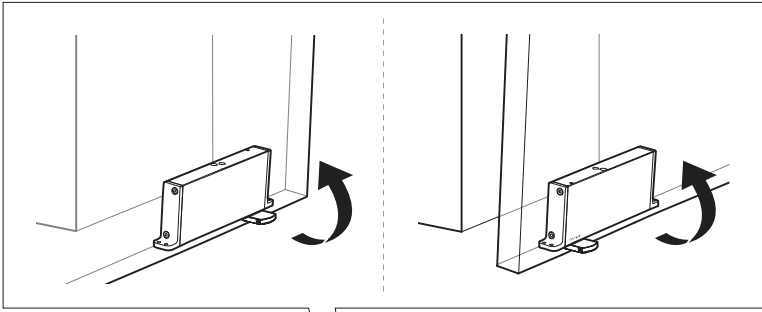

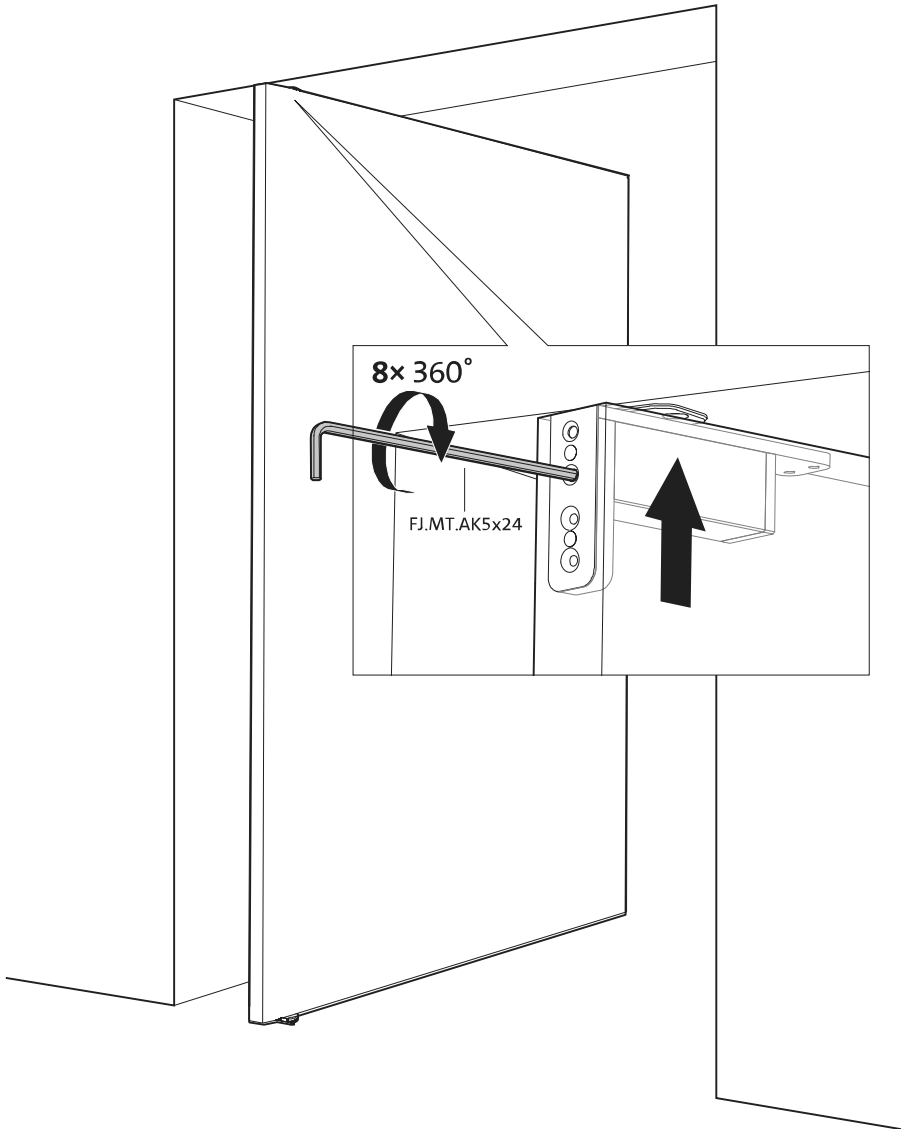
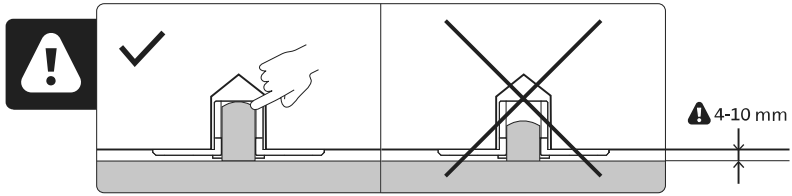

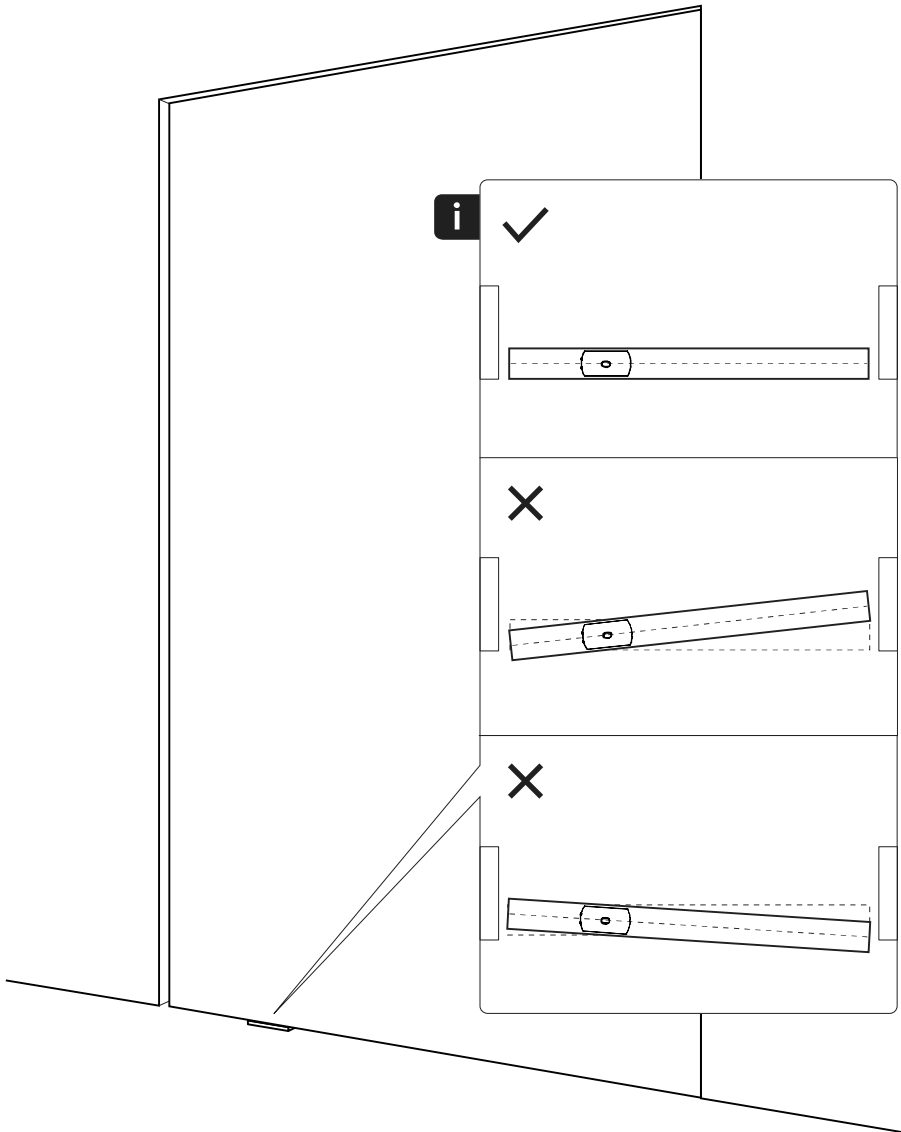



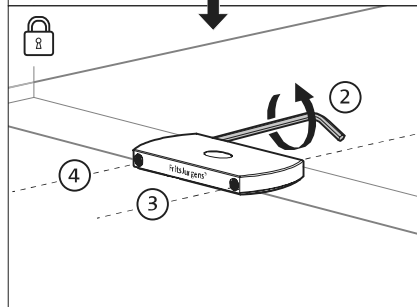
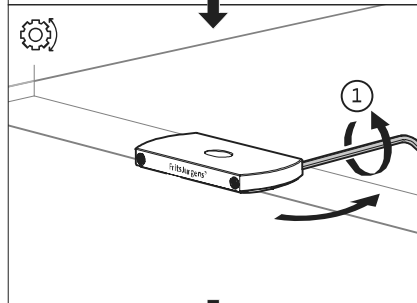
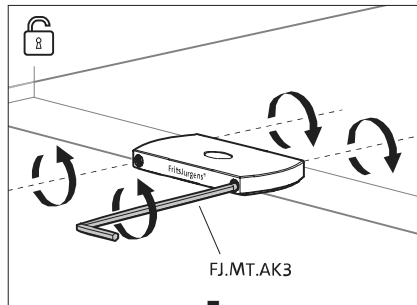
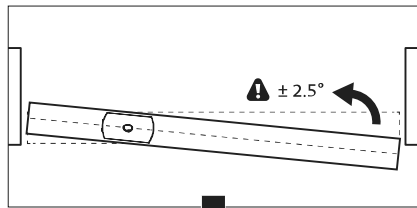
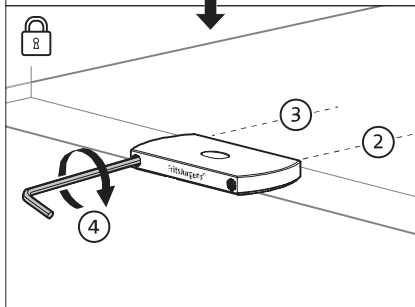
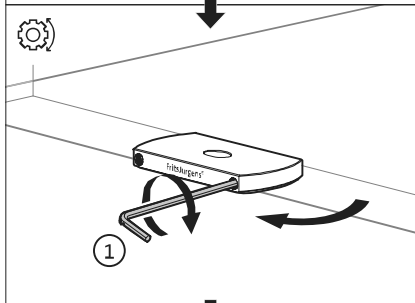
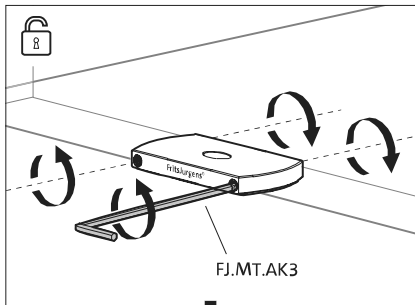
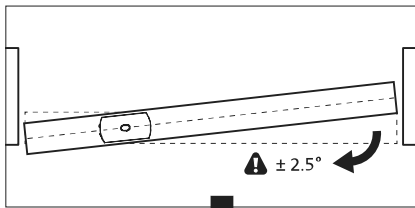

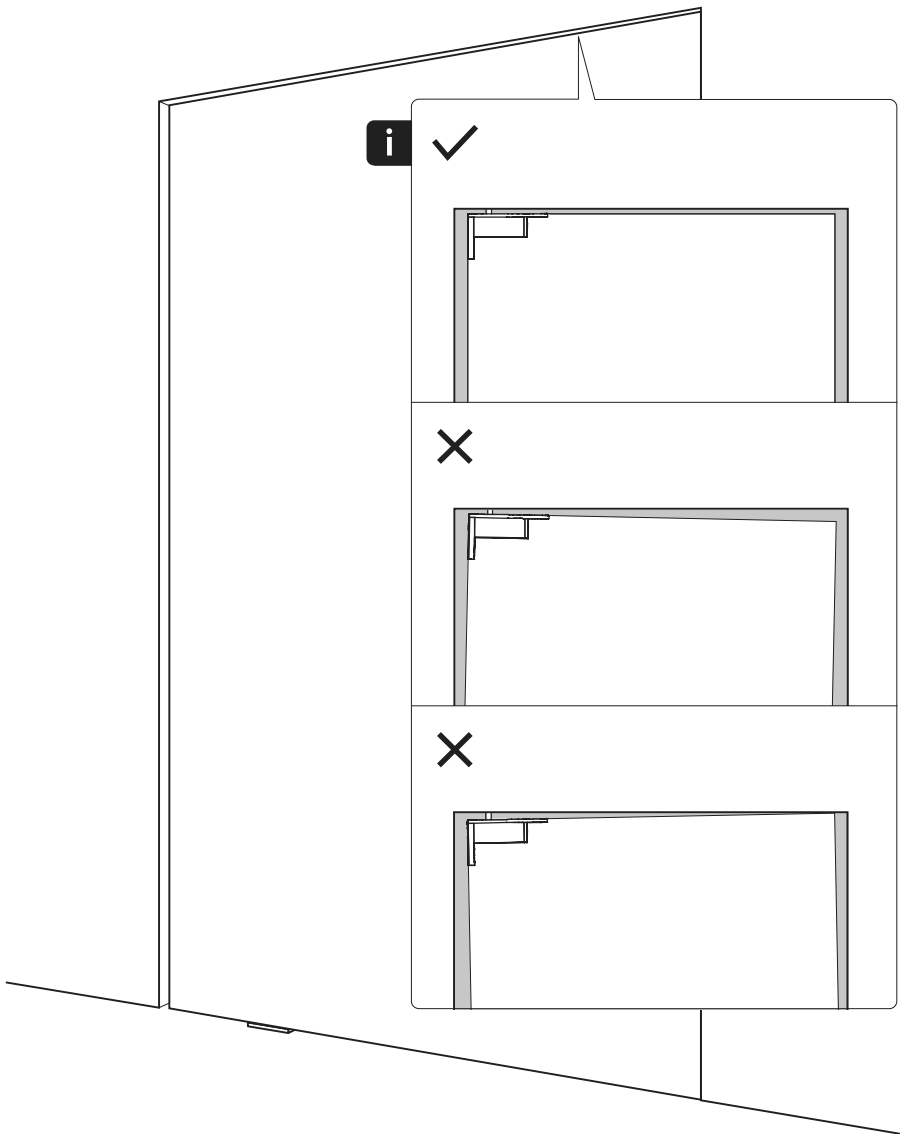

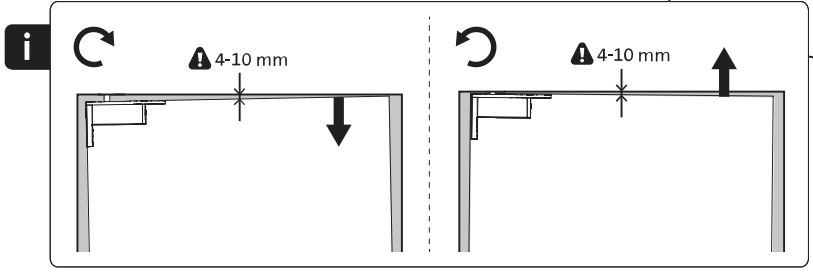
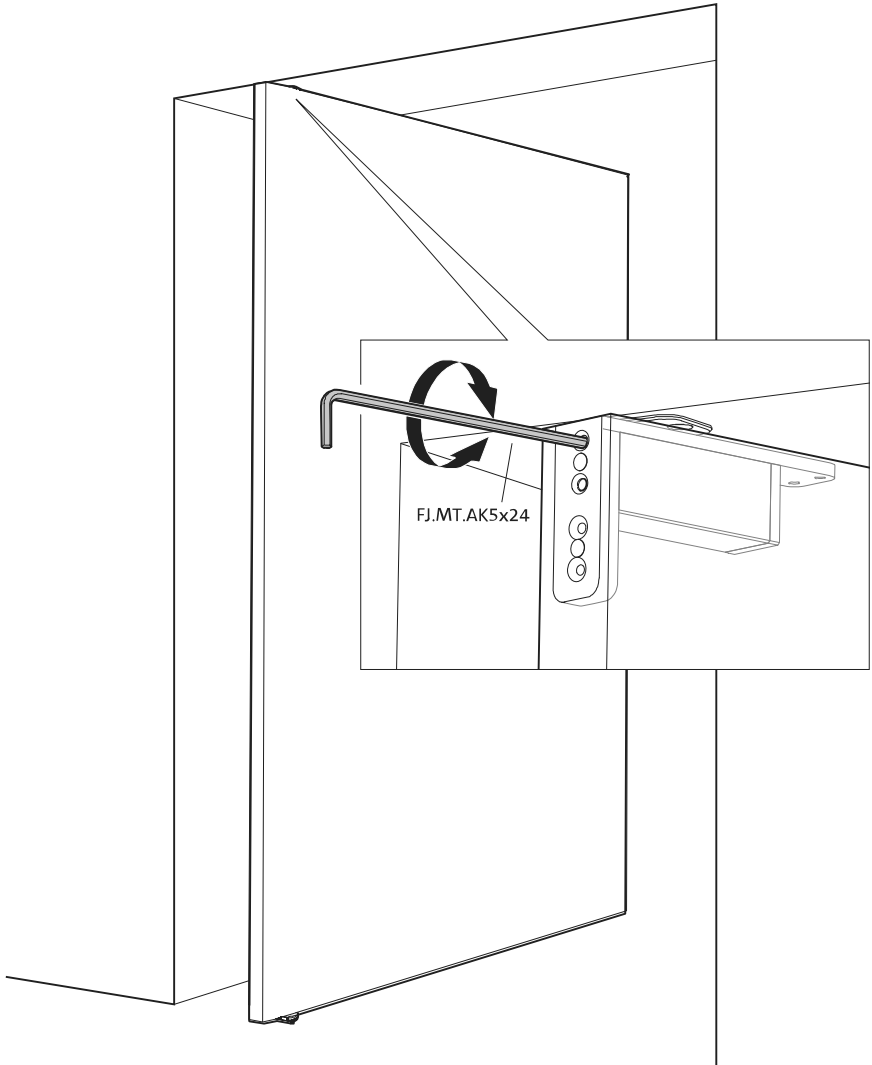

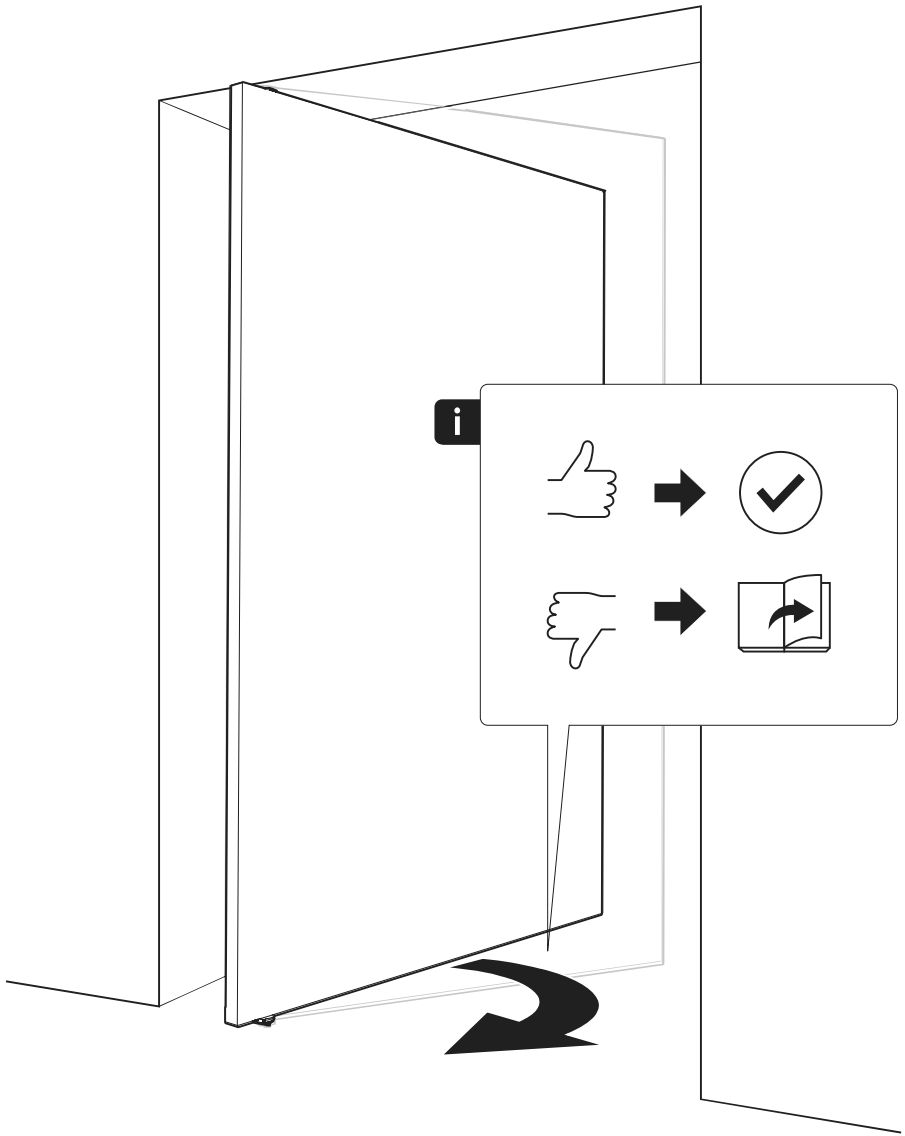



FJ.MT.AC.M+

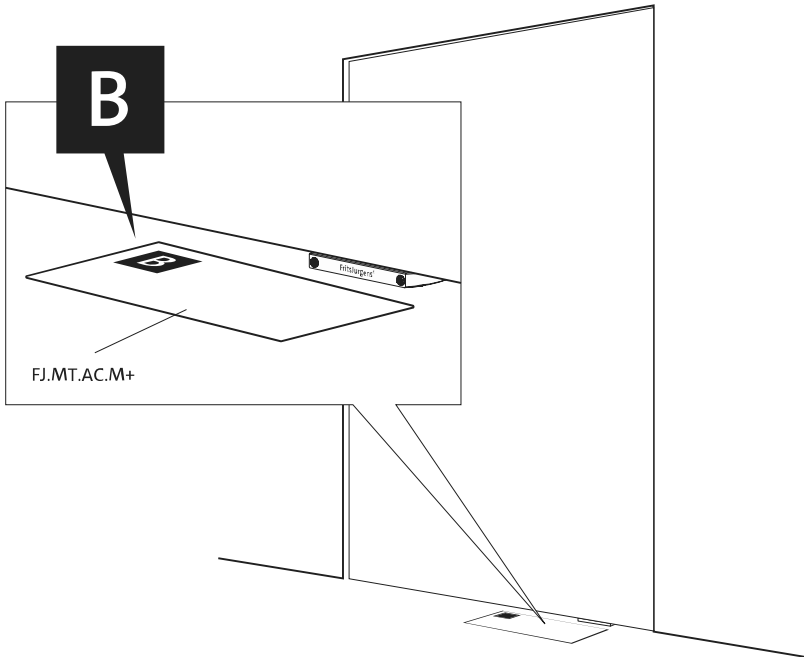
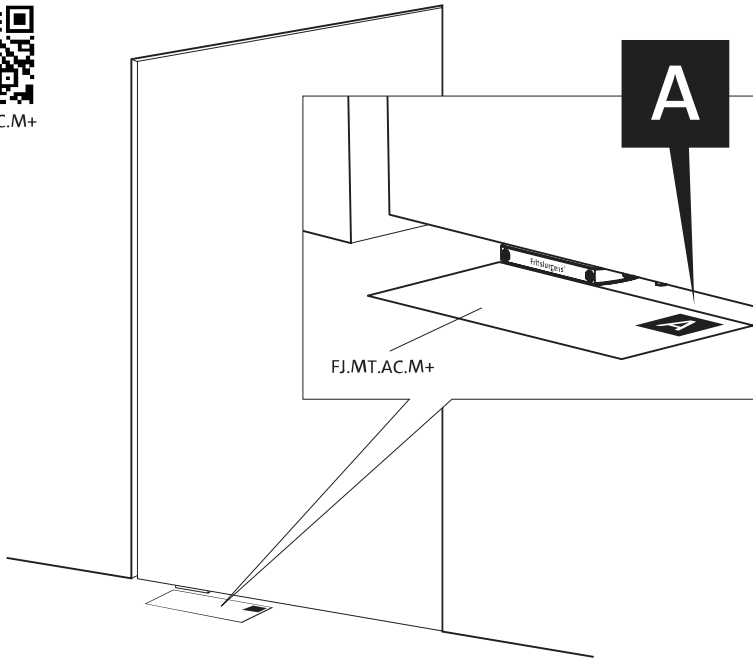

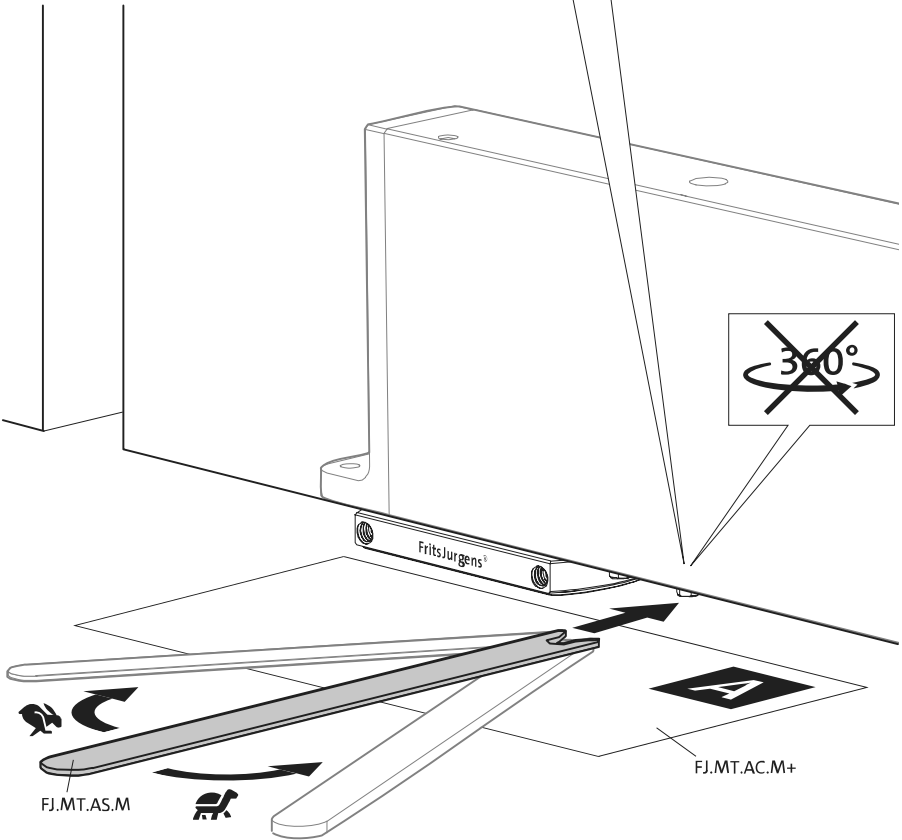
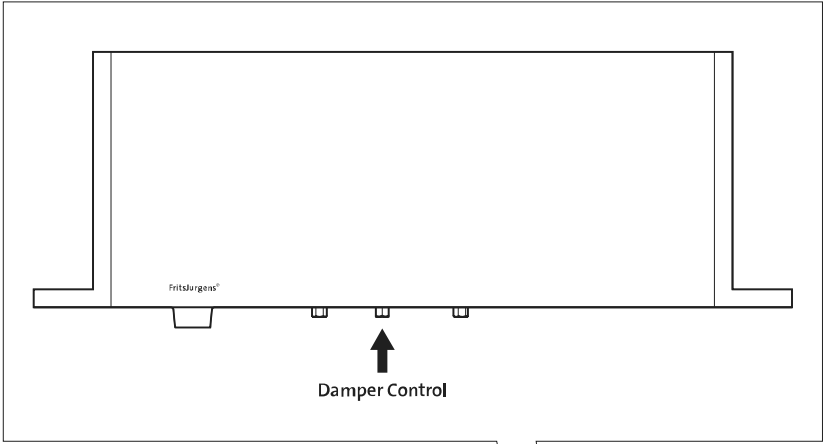

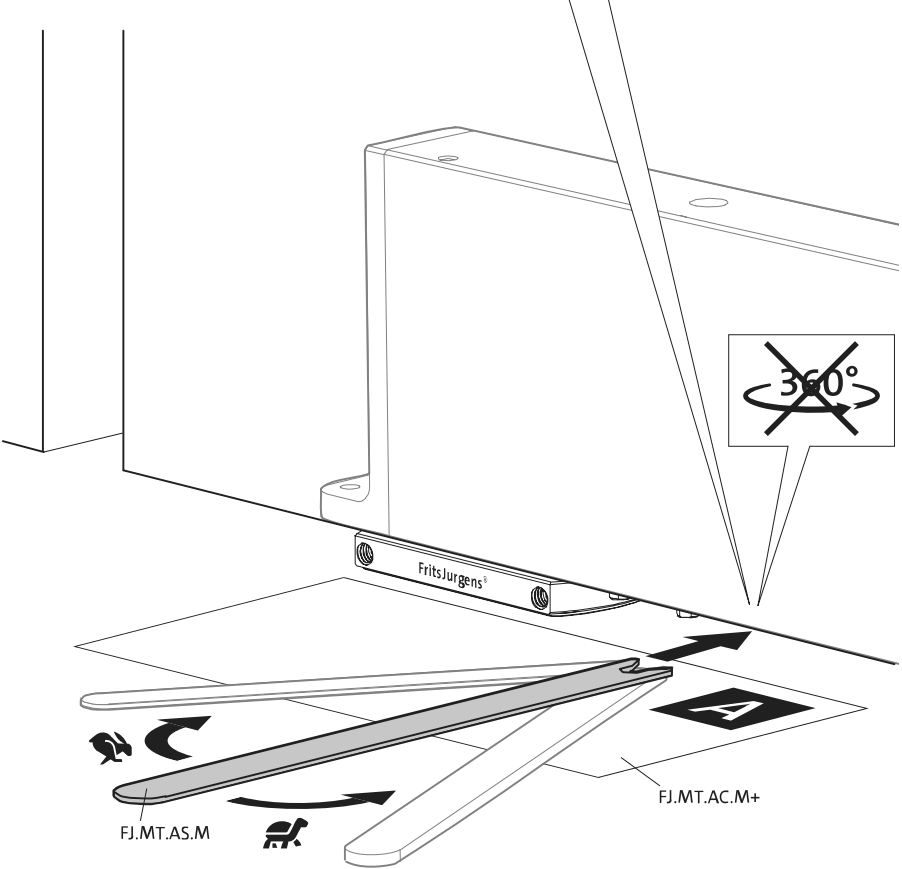
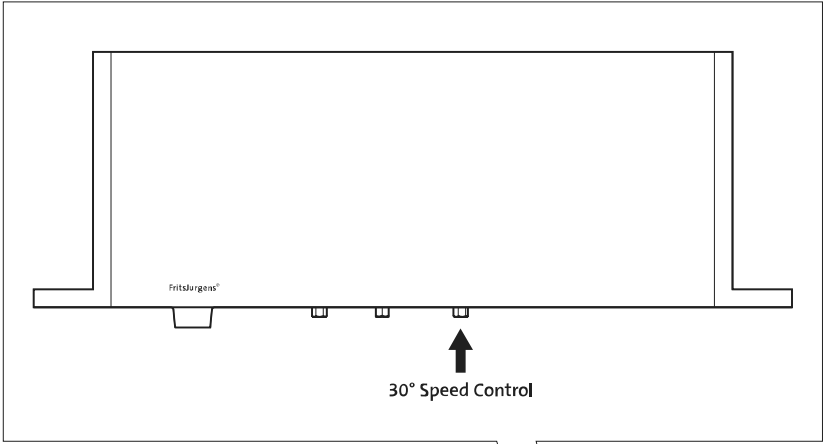

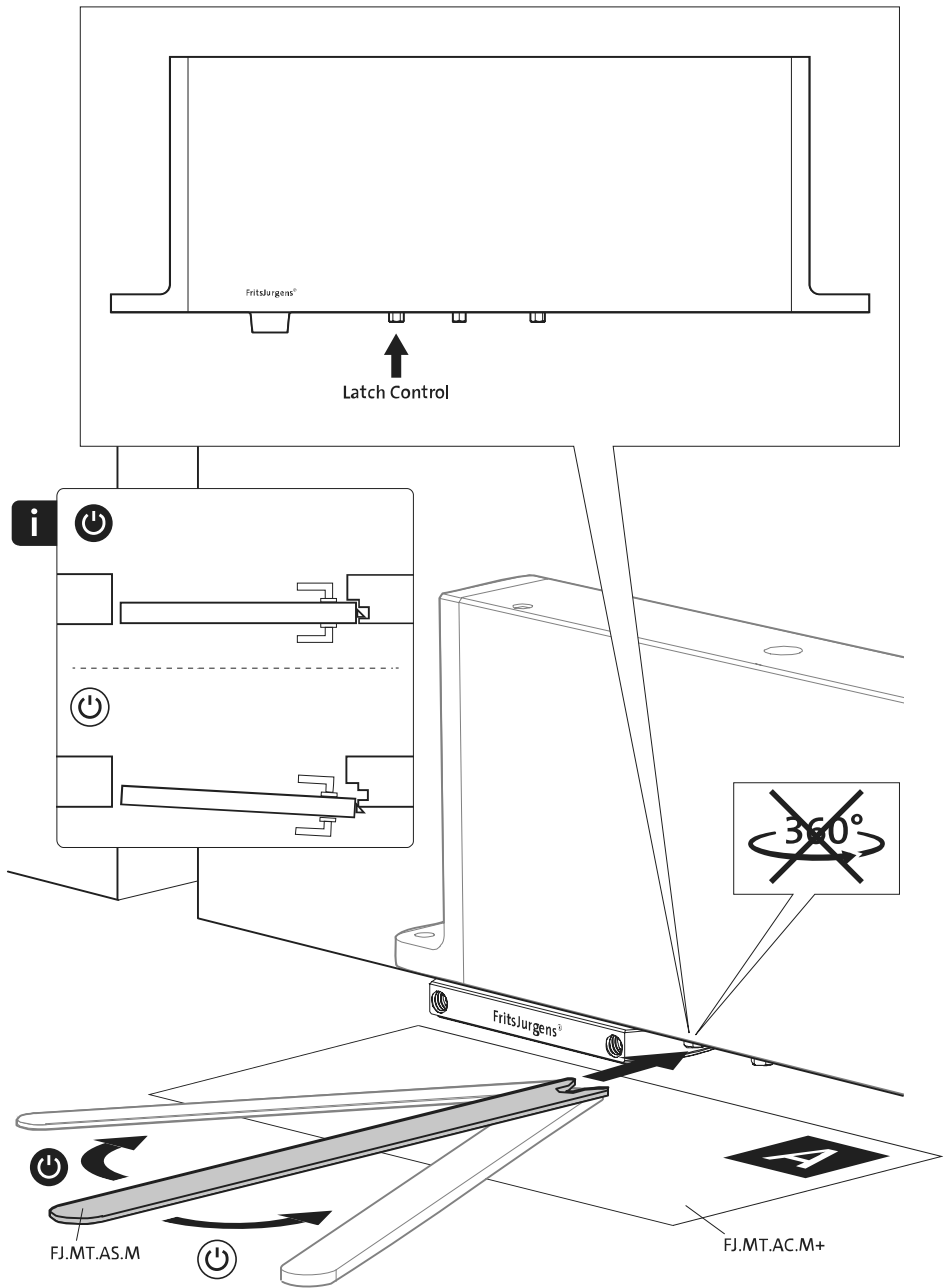



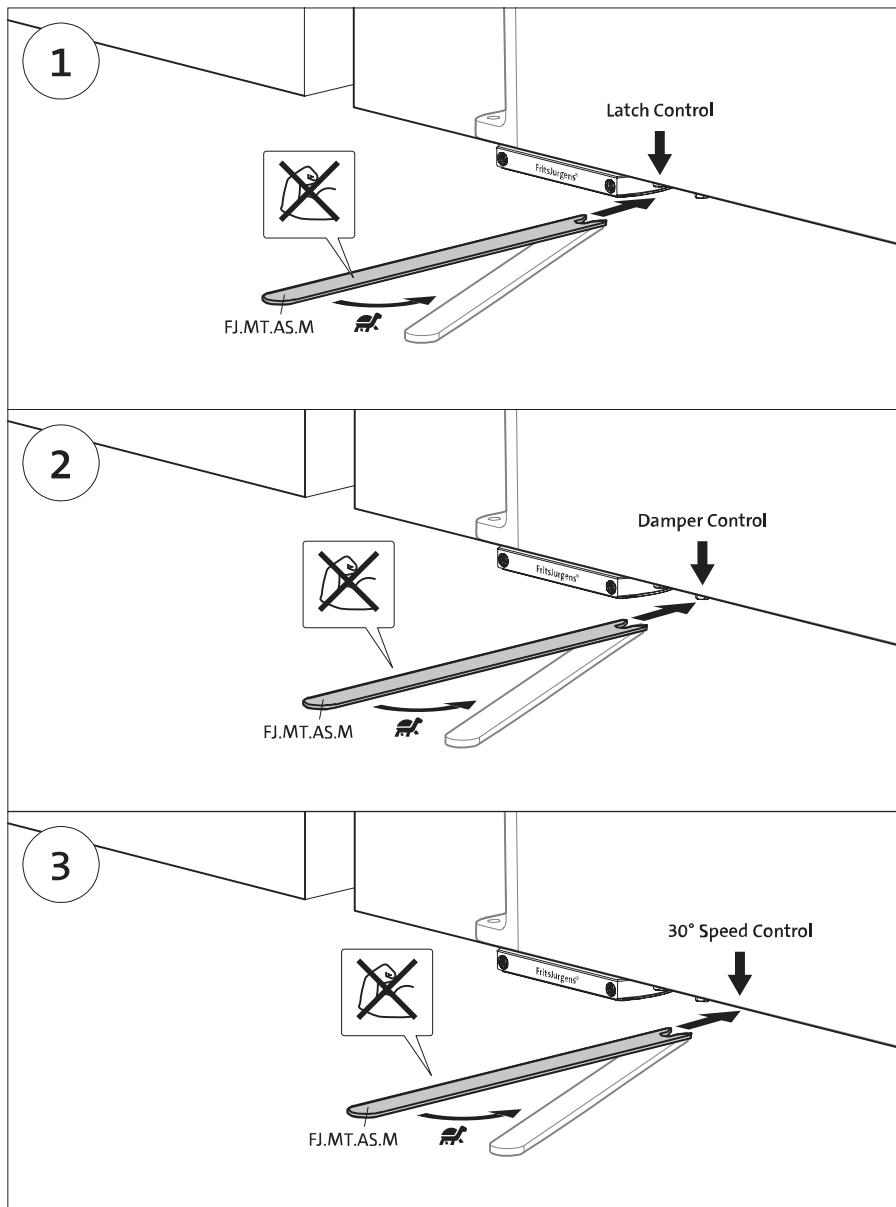

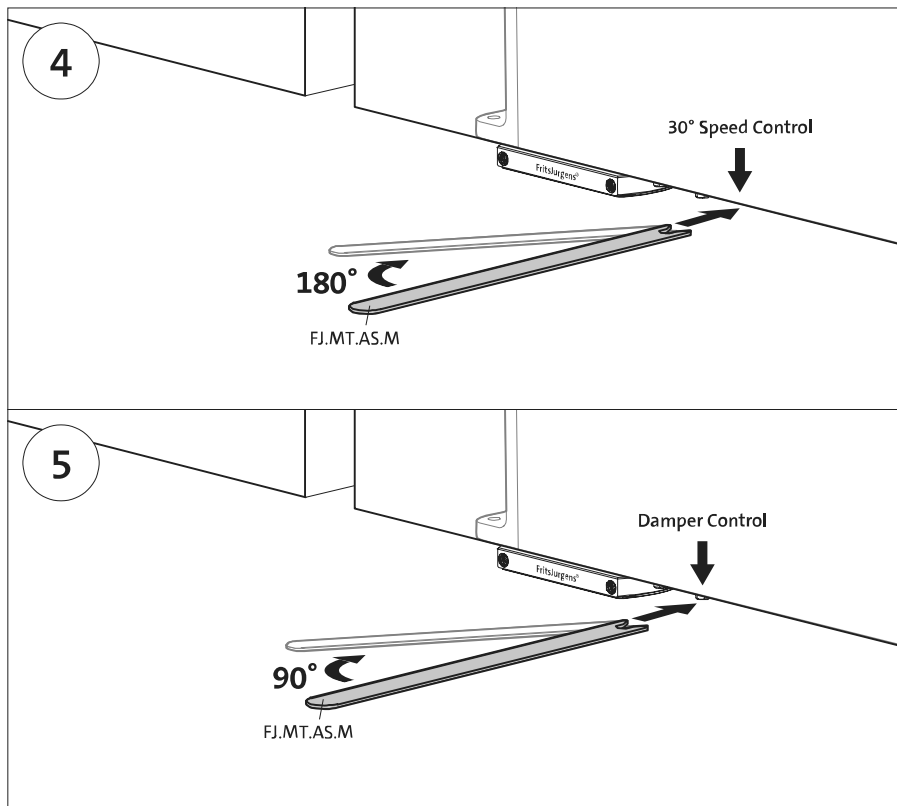

# Istruzioni di smontaggio

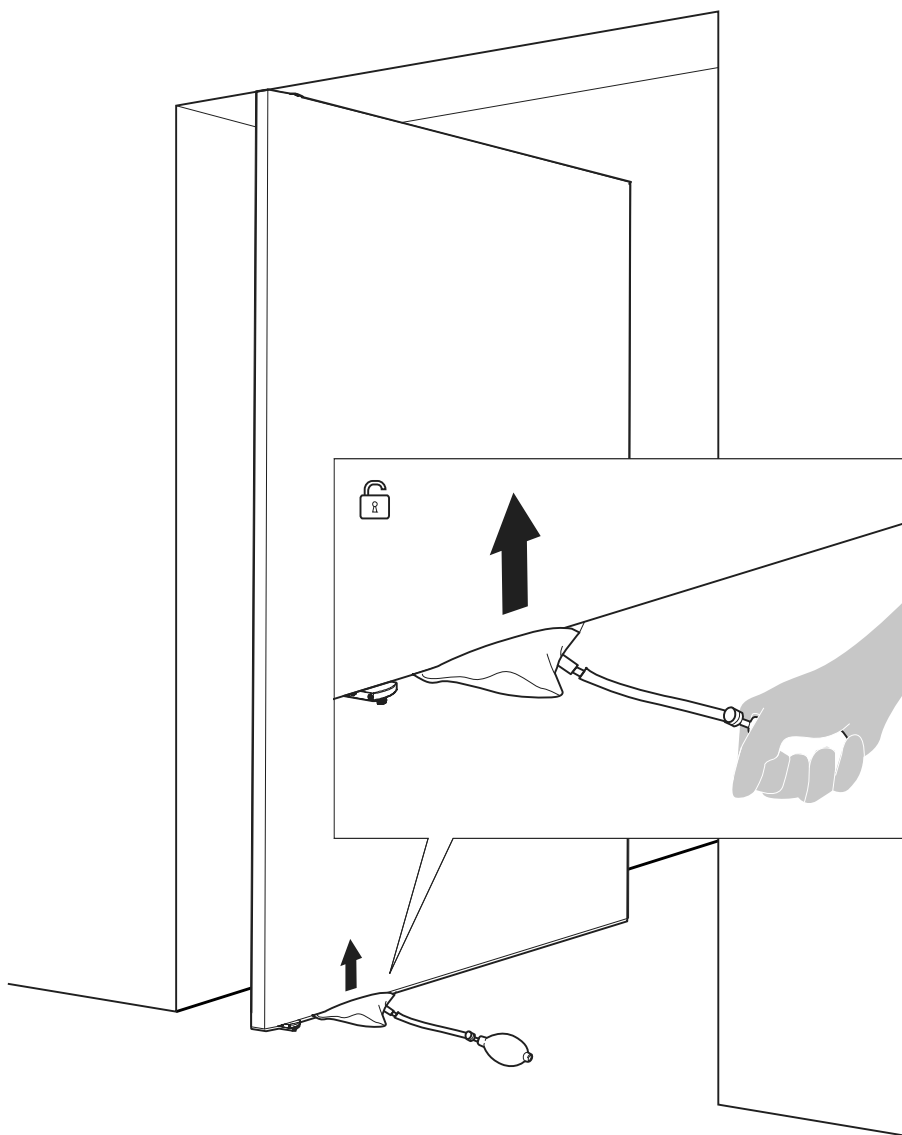

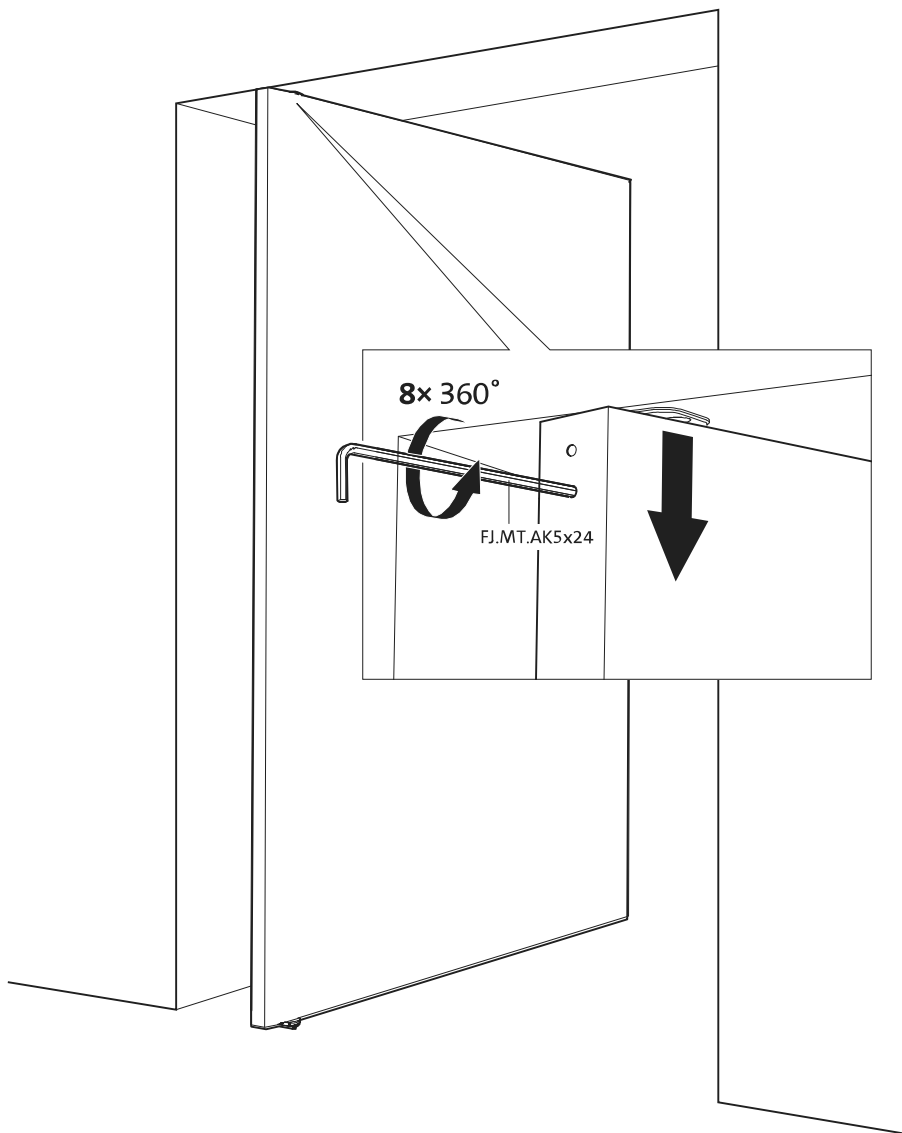





**FritsJurgens International**

A. Einsteinlaan 1

Paesi Bassi

9615 TE Kolham

+31 598 343 410

info@fritsjurgens.com

**FritsJurgens Dubai Branch**

DLC-OP-A2-4-0029

Dubai South

Dubai

Emirati Arabi Uniti

+971 4 820 8106

+971 58 137 2611

dubai@fritsjurgens.com

fritsjurgens.com

Copyright © FritsJurgens®  
BPM+.40.A.X.SS





