

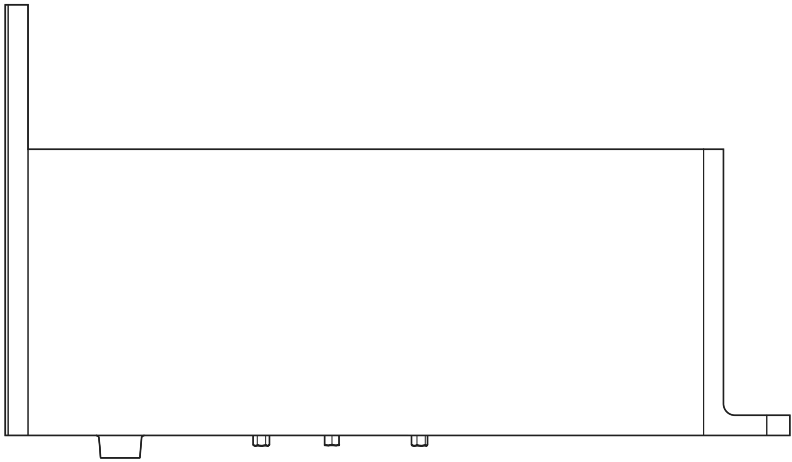

System M+

Manuale di fresatura e montaggio

FritsJurgens Kit - 40 mm Classe C - acciaio inox



FritsJurgens®

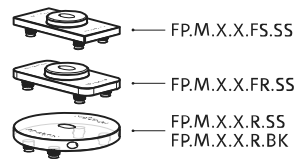
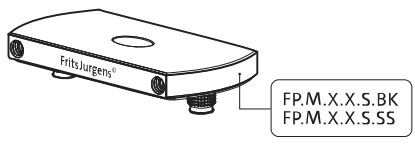
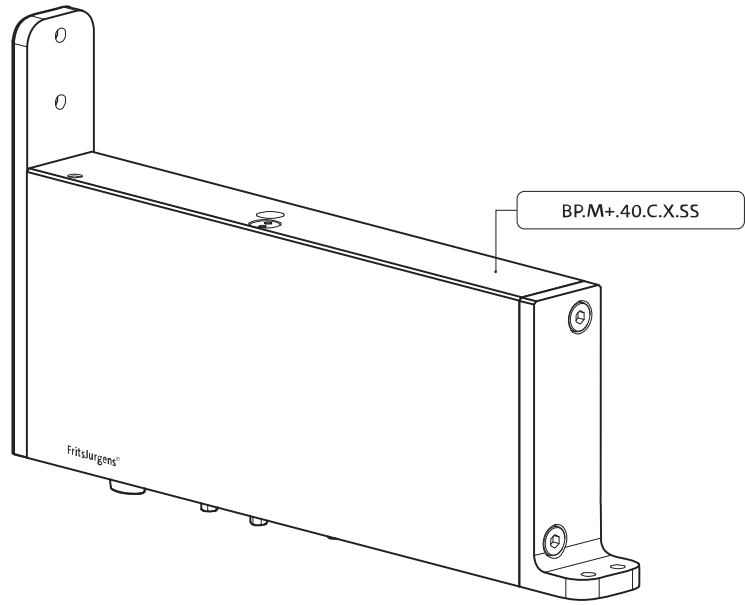
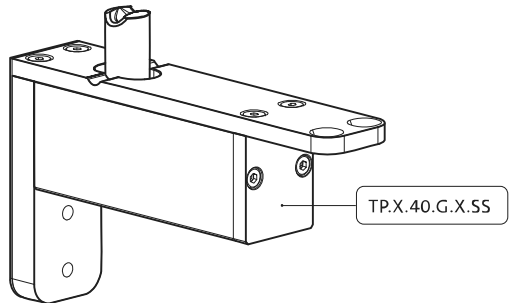
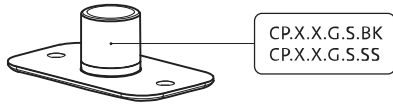

Istruzioni di fresatura

BP.M+.40.C.X.SS

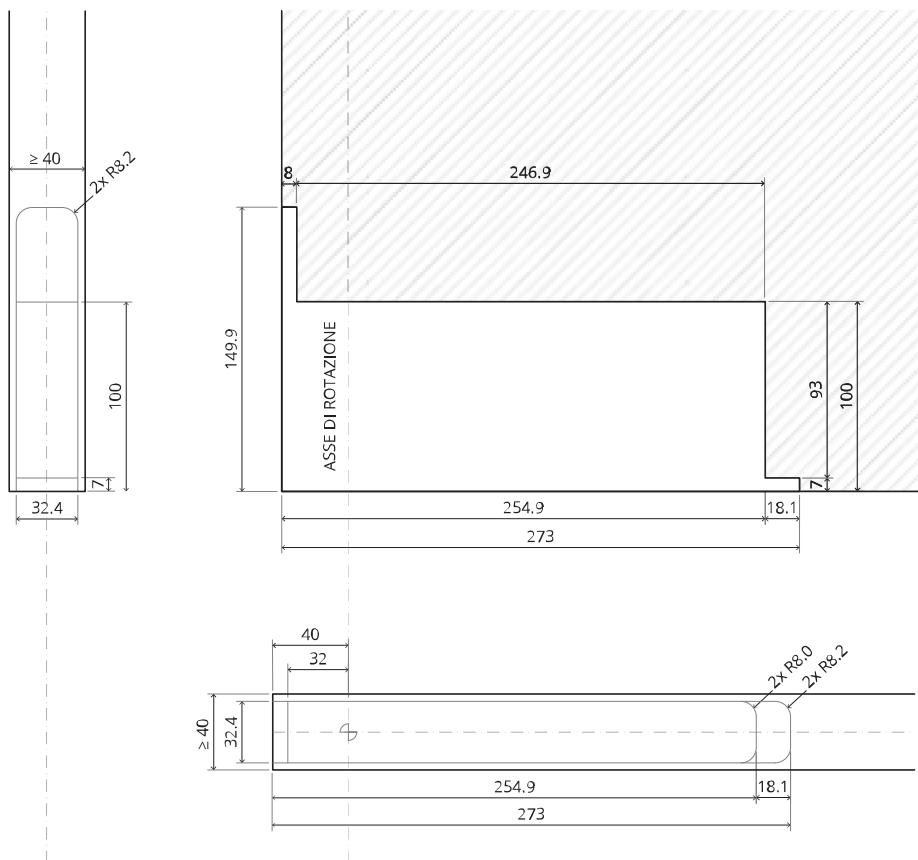

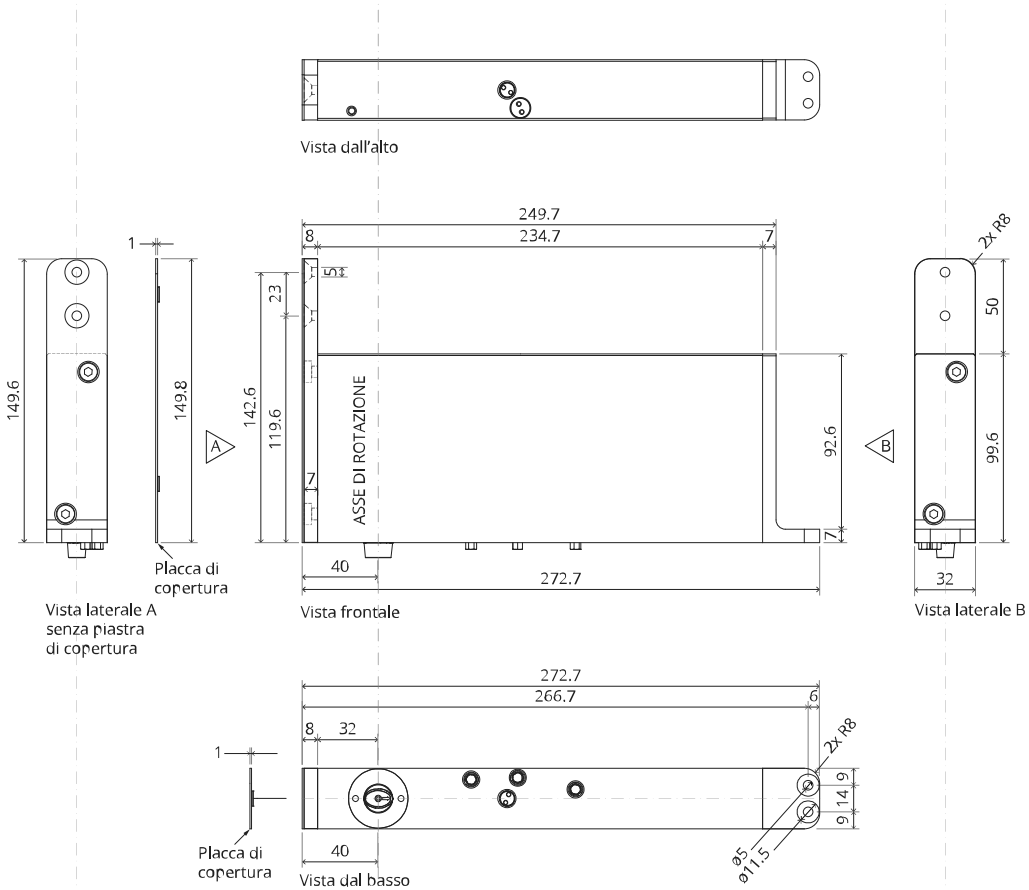

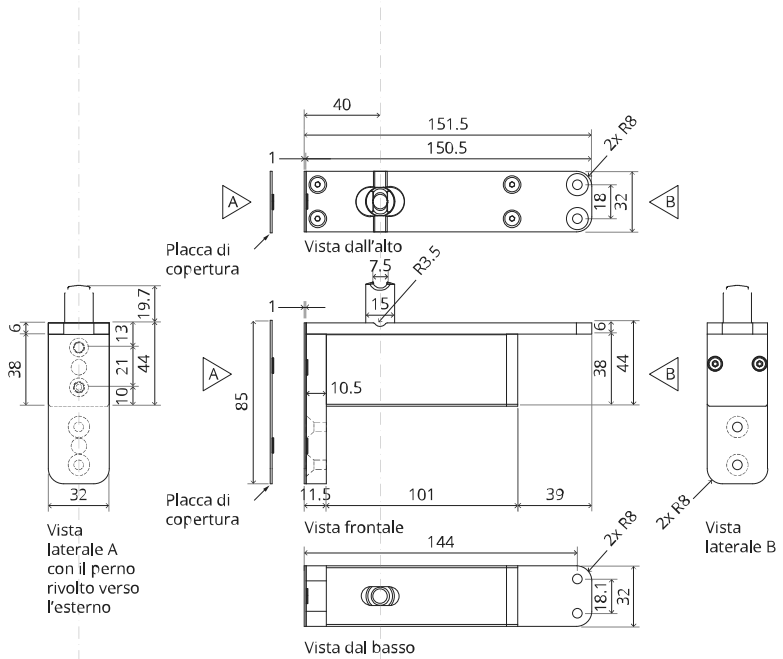

FP.M.X.X.FS.SS

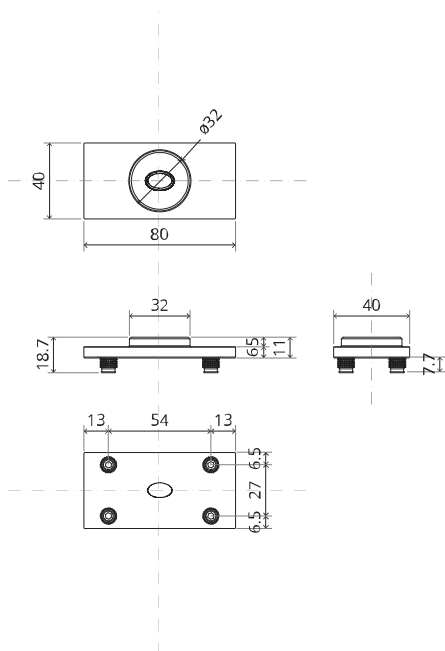
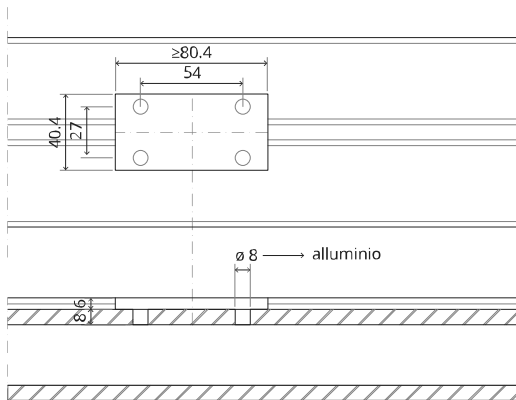

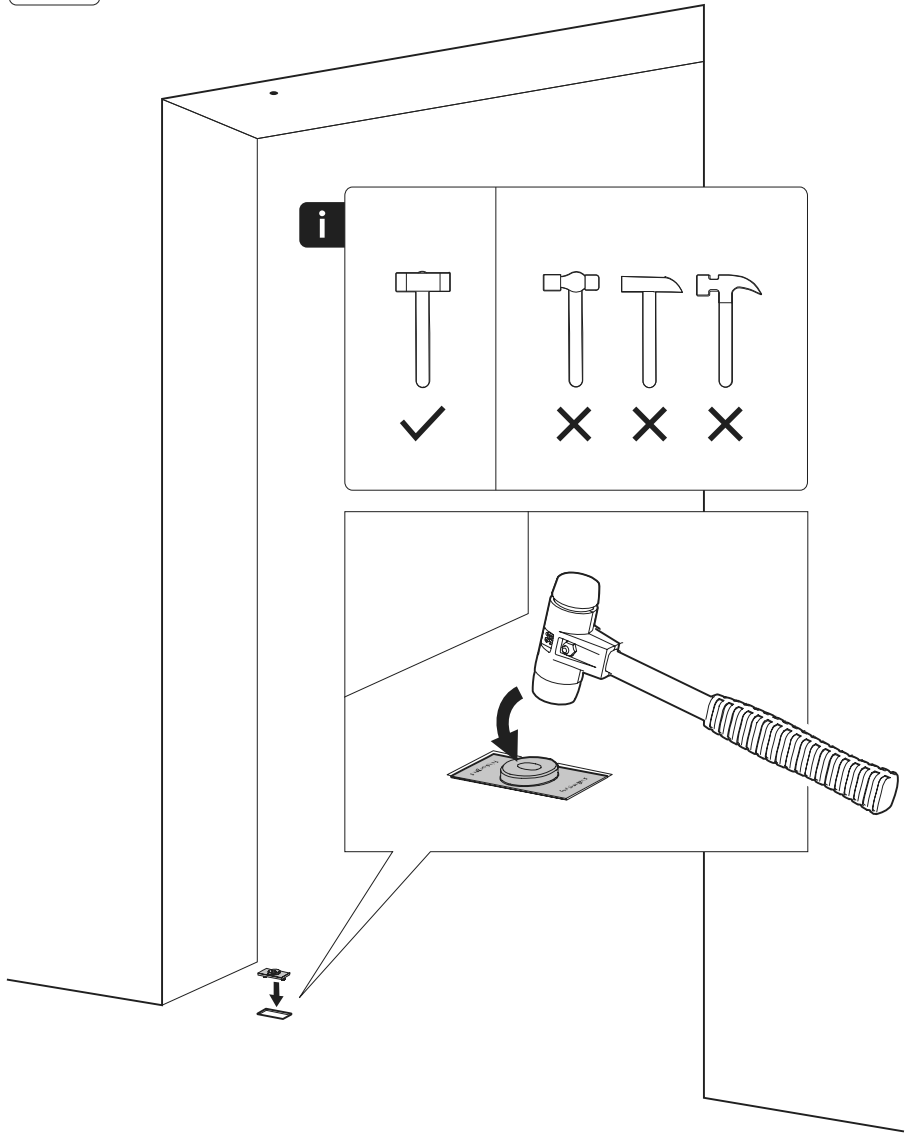

FP.M.X.X.FR.SS

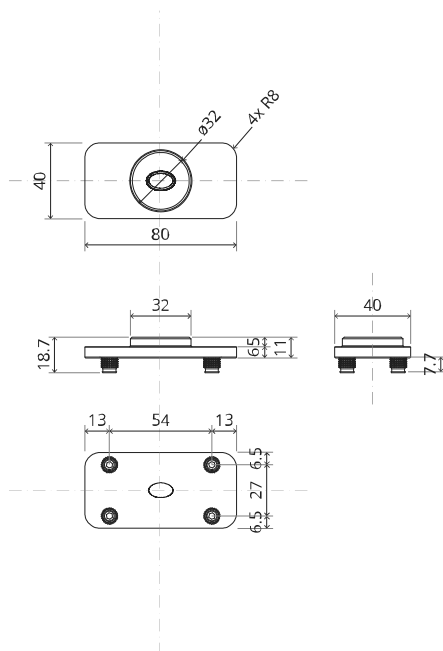
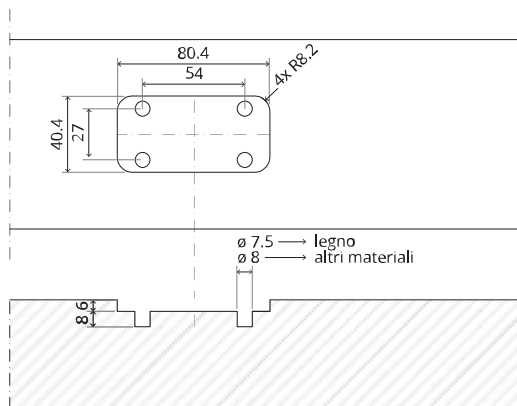

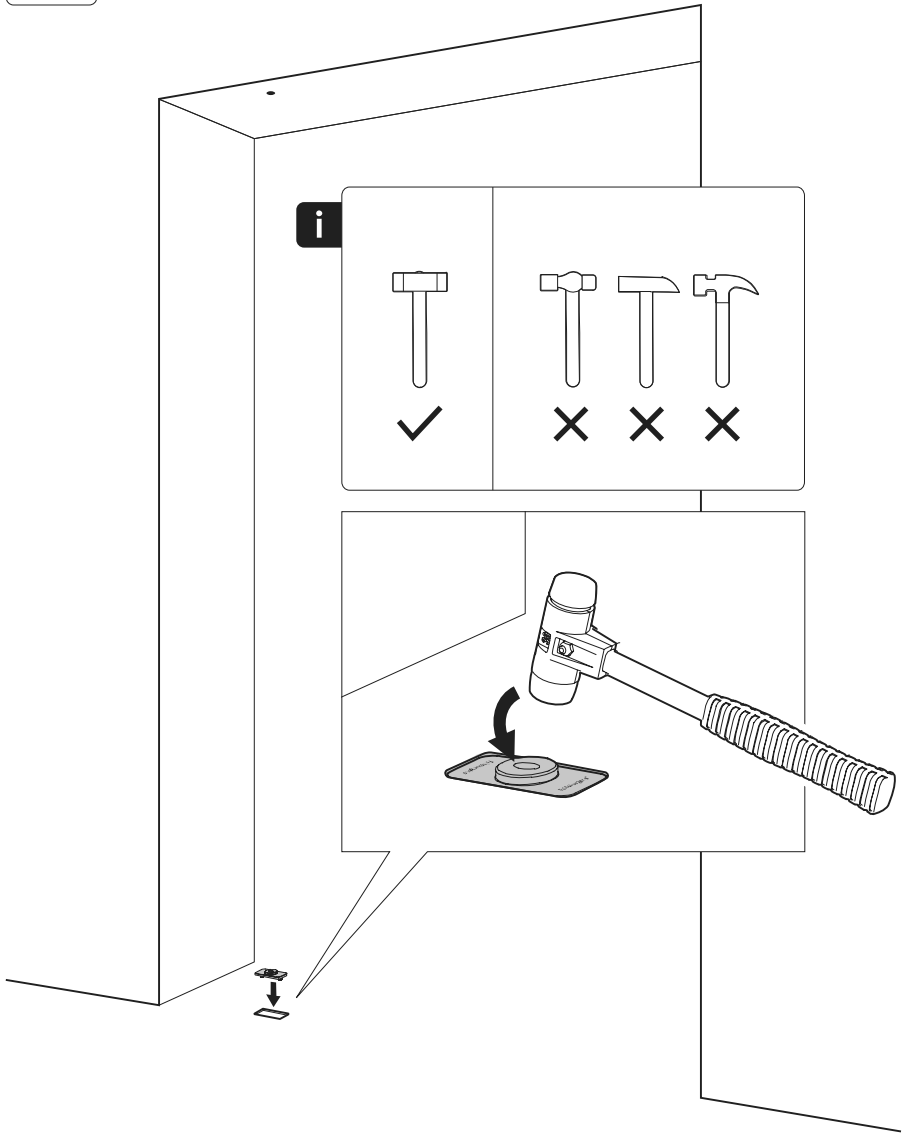

Istruzioni di montaggio

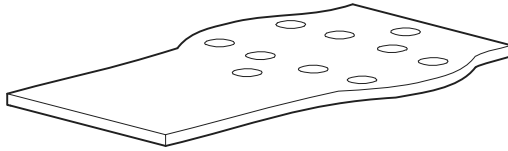

FJ.MT.DT.M



FJ.MT.Z5



10x FJ.Tx.4.0X50.PKDD



FJ.Bit.Tx20

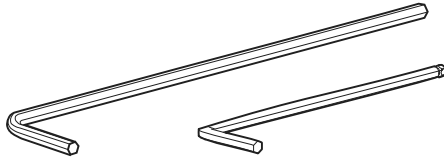

FJ.MT.AK3

FJ.MT.AK5x24

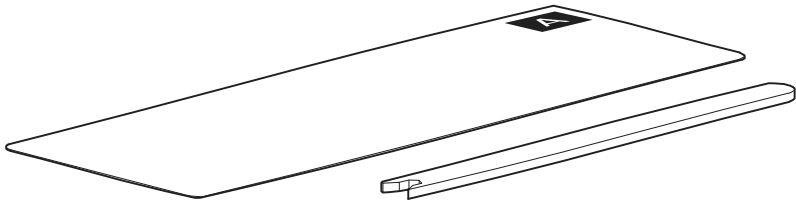

FJ.MT.AC.M+

FJ.MT.AS.M

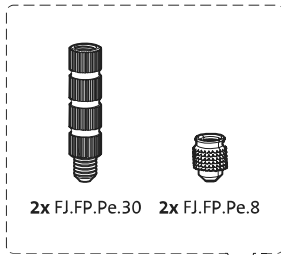

2x FJ.FP.Pe.30 2x FJ.FP.Pe.8

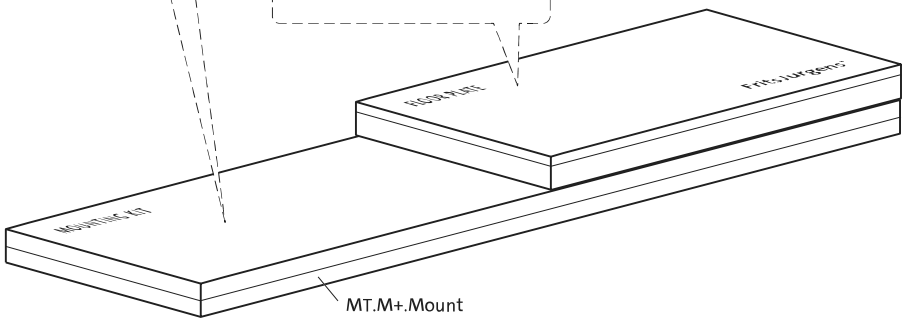

MT.M+.Mount

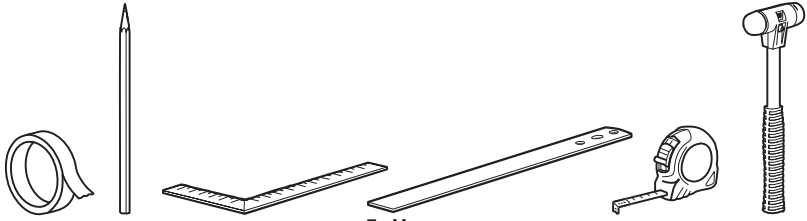

To.M

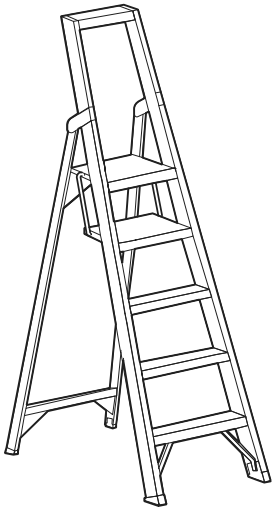
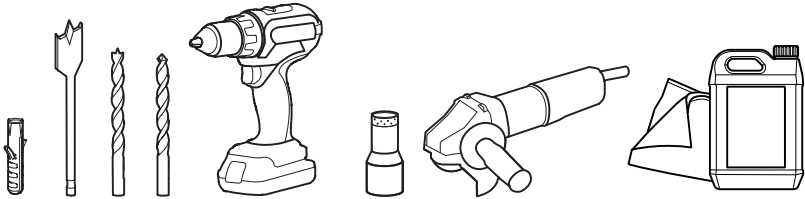

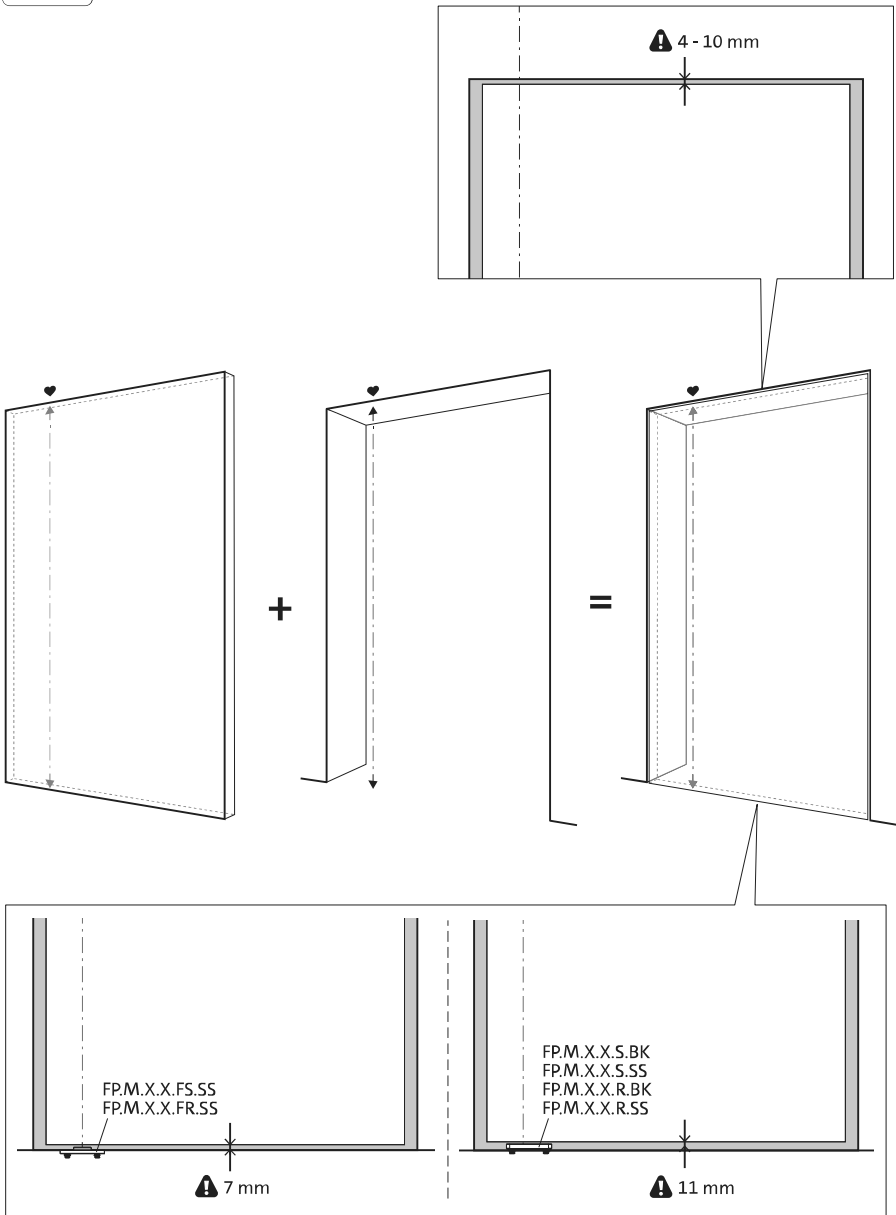



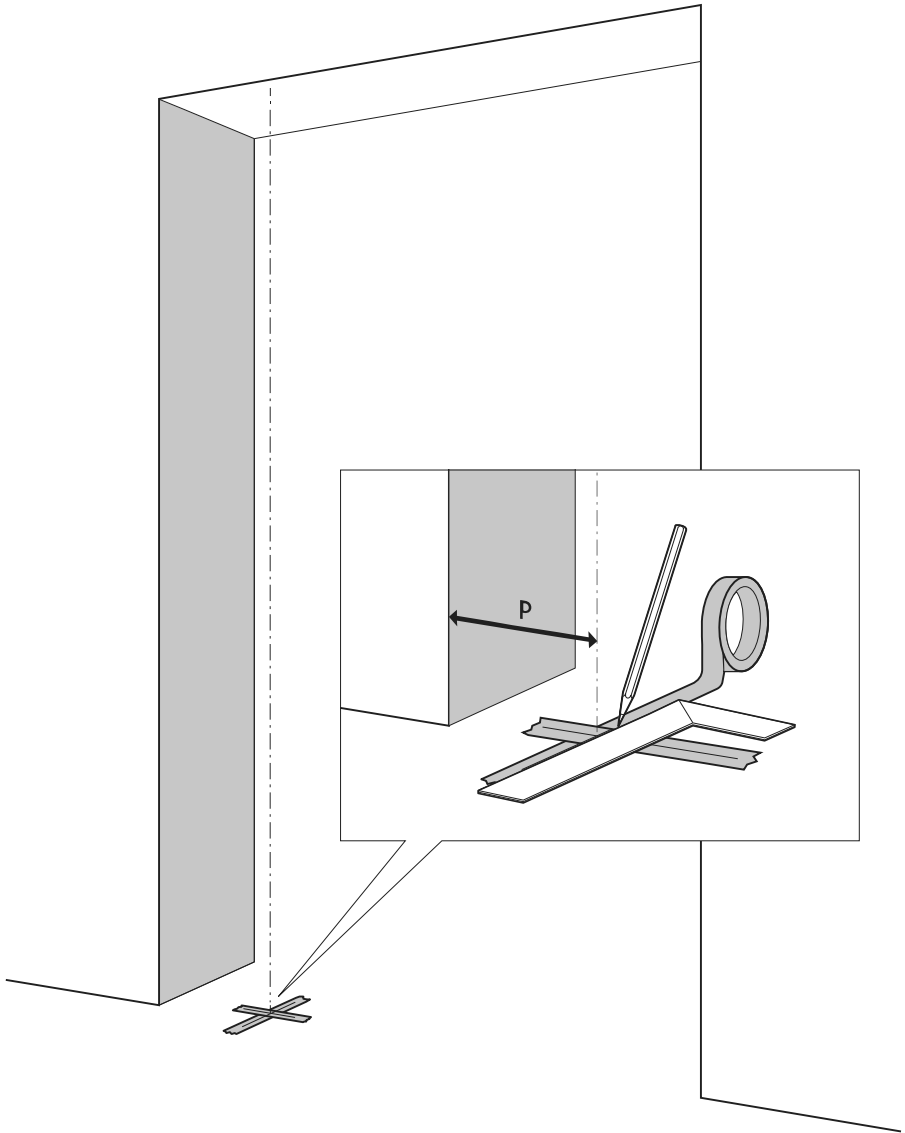

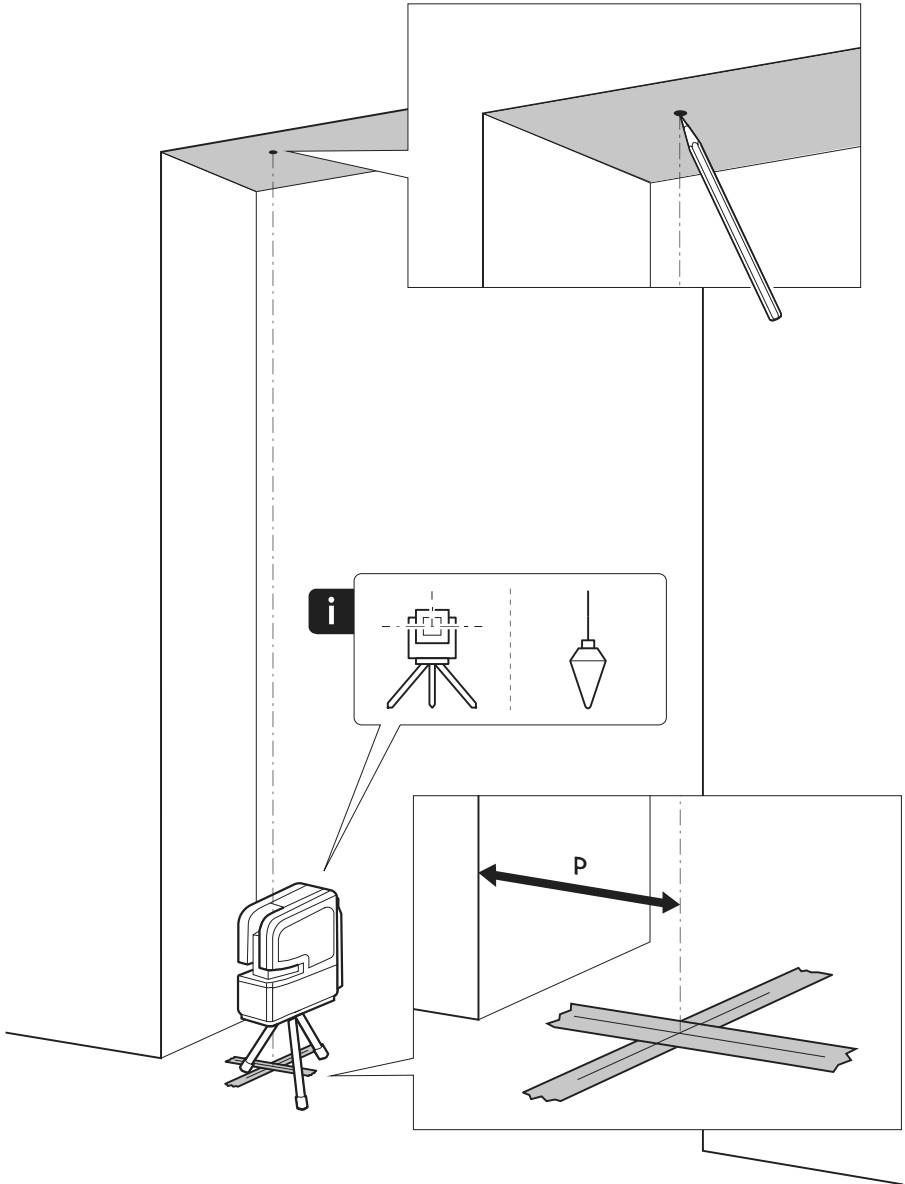

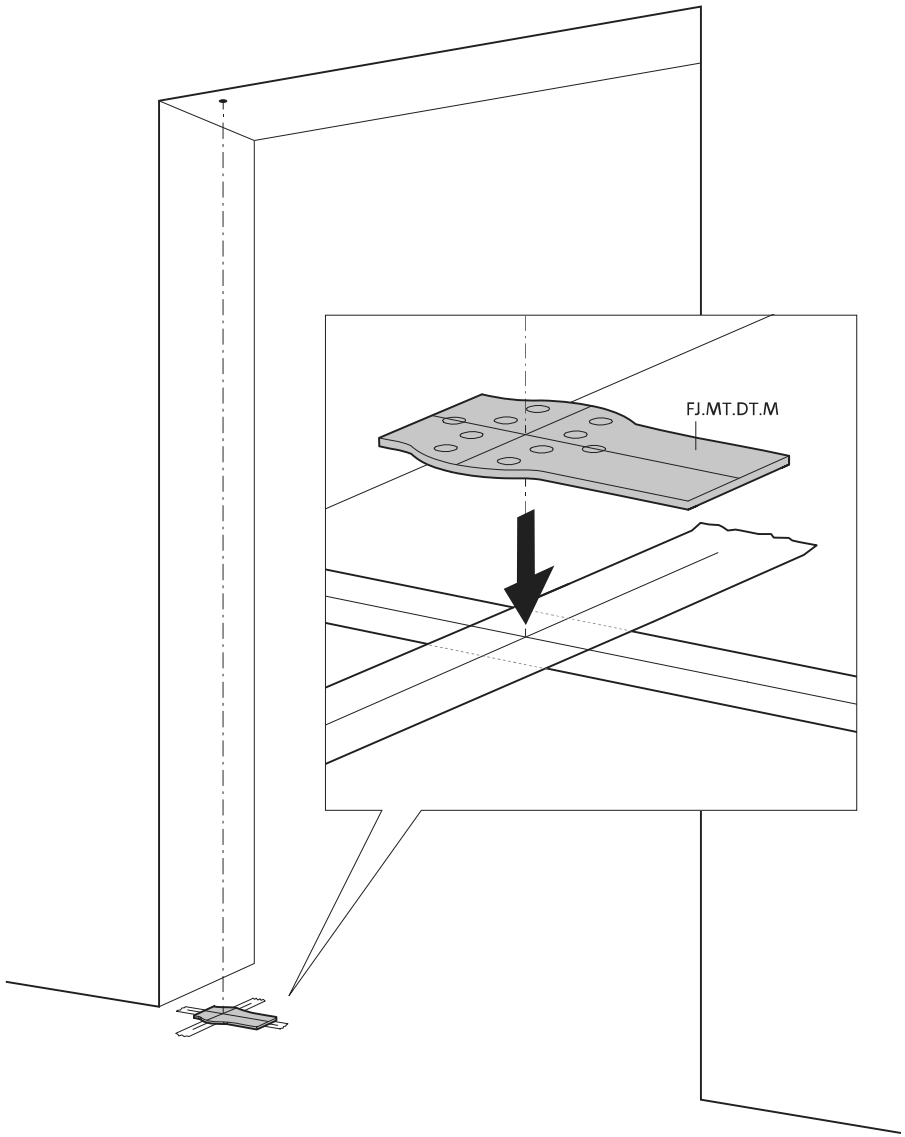

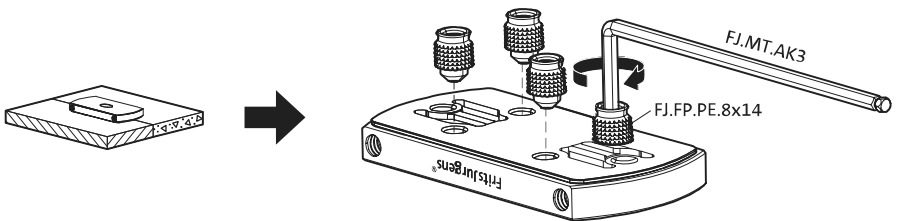
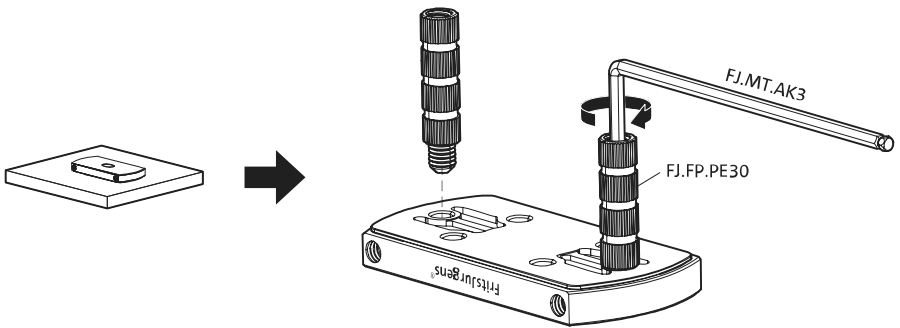
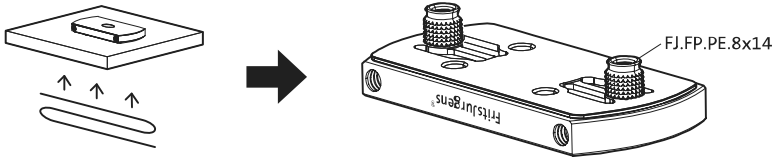



ø8 mm (5/16")

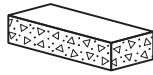
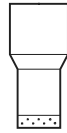

ø8 mm (5/16")

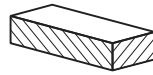

ø7.5 mm (19/64")

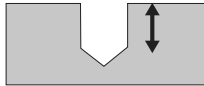

8 mm (5/16")

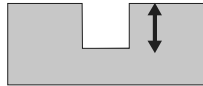

8 mm (5/16")

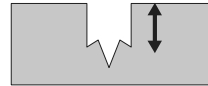

8 mm (5/16")

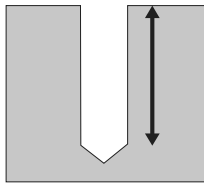
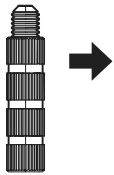

30 mm (13/16")

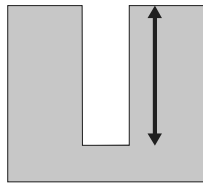

30 mm (13/16")

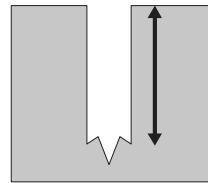

30 mm (13/16")

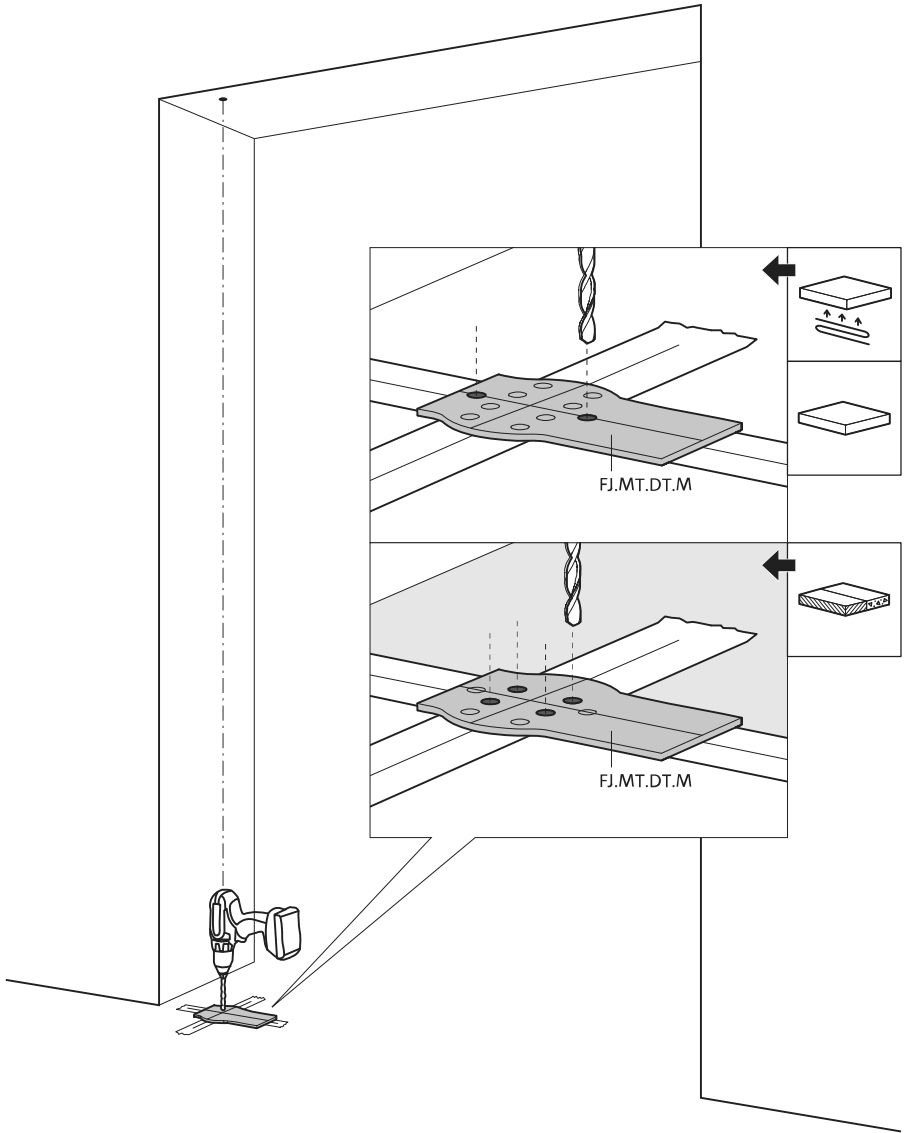

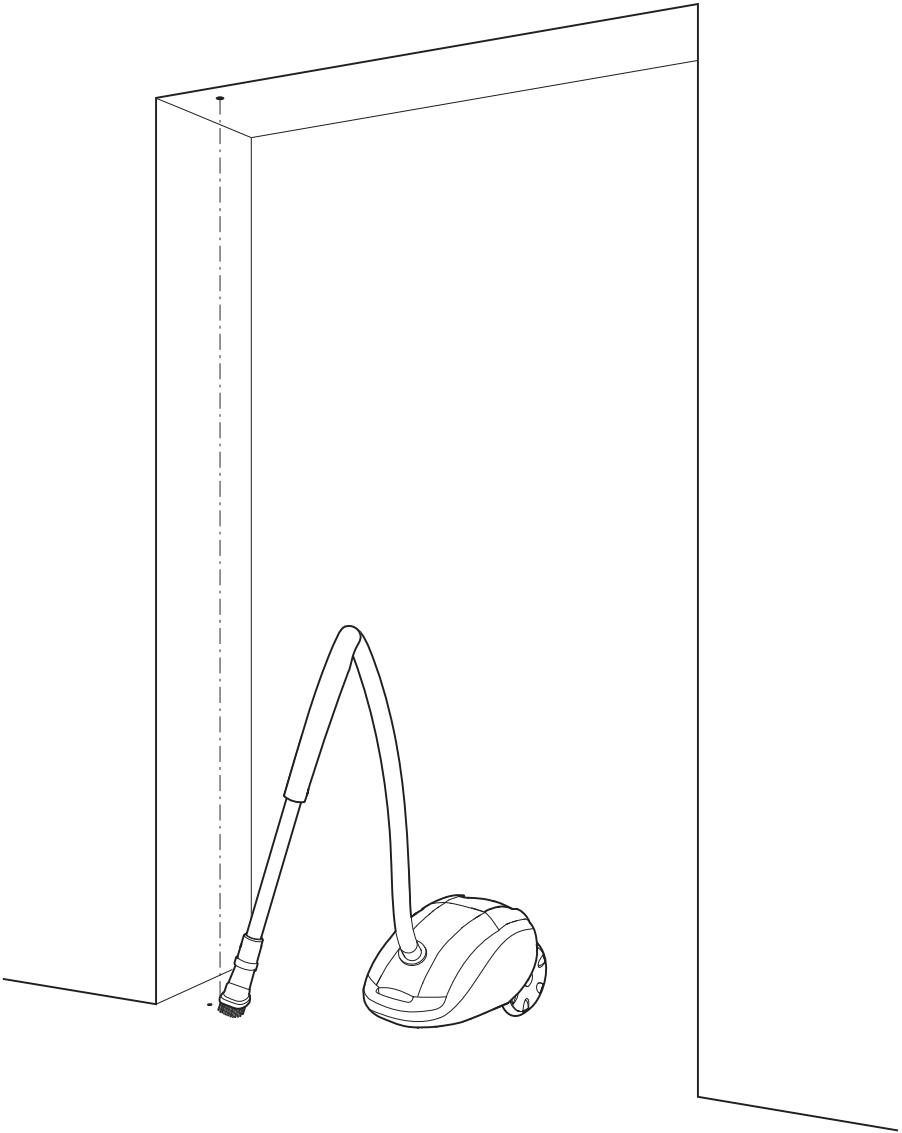



1

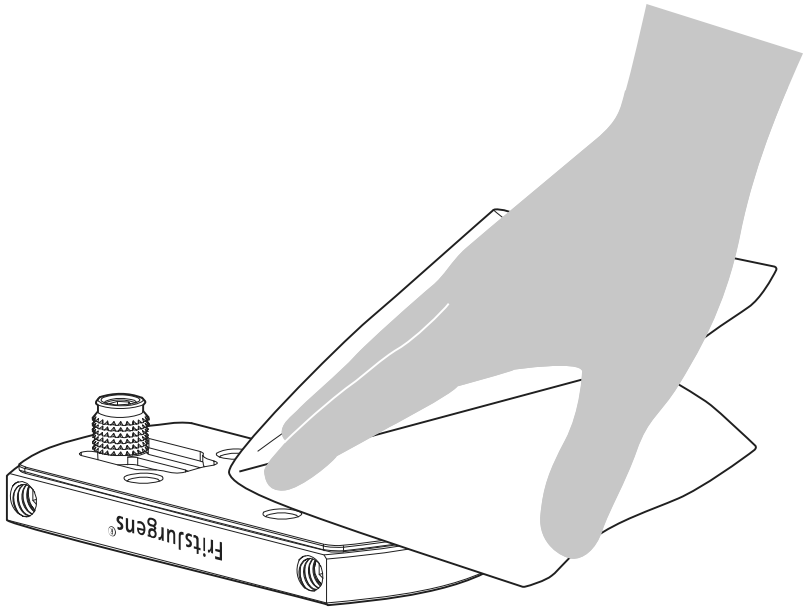

2

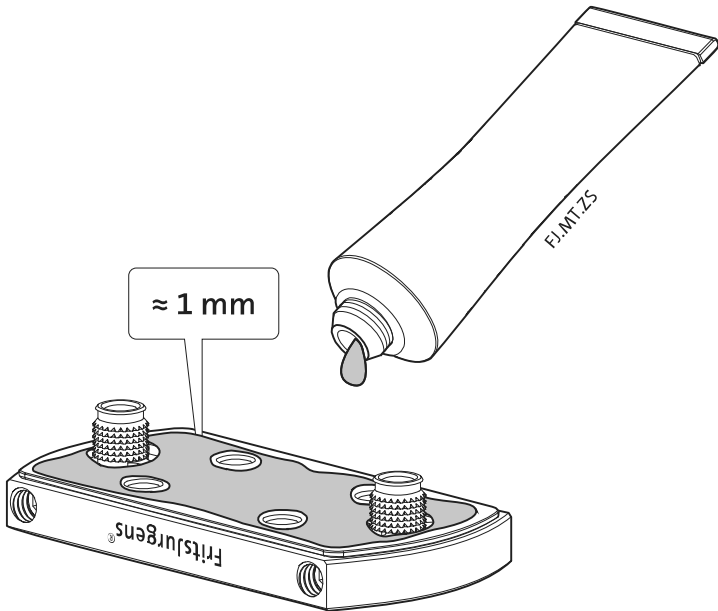

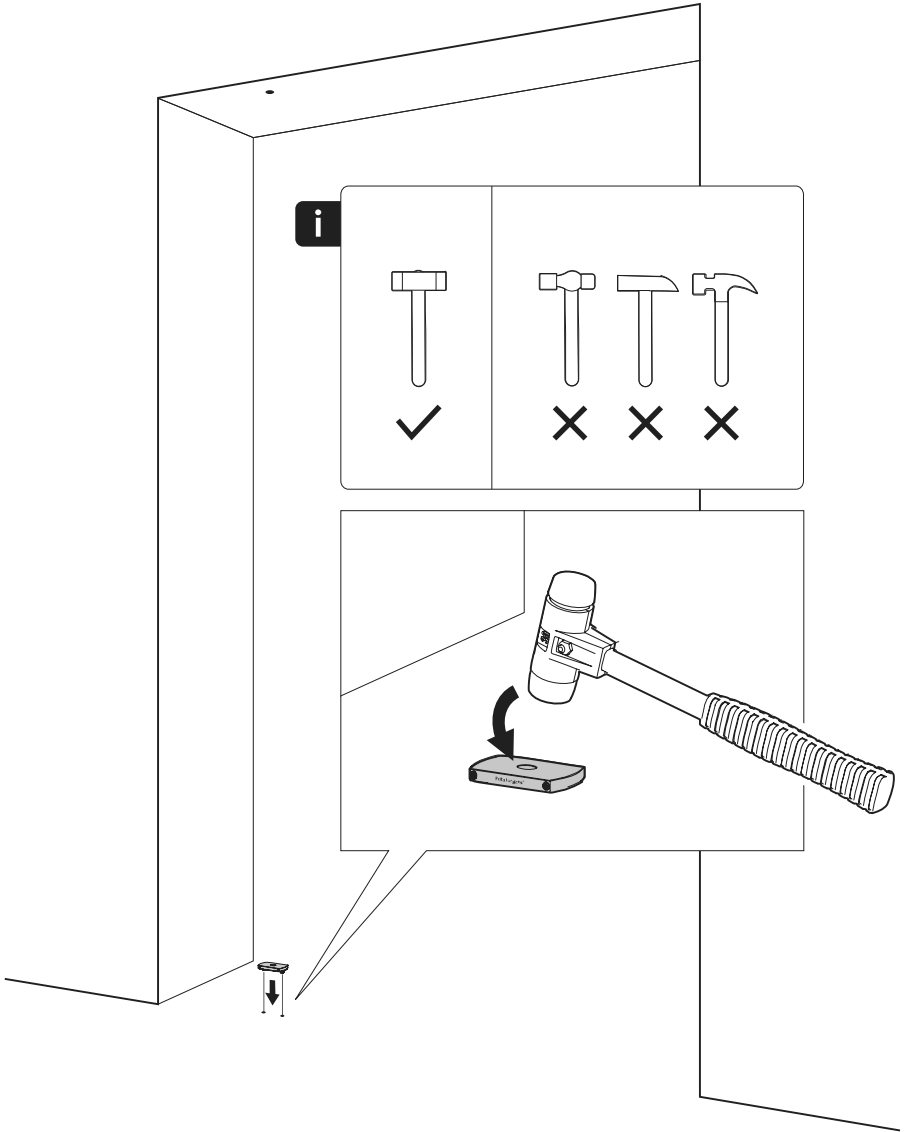

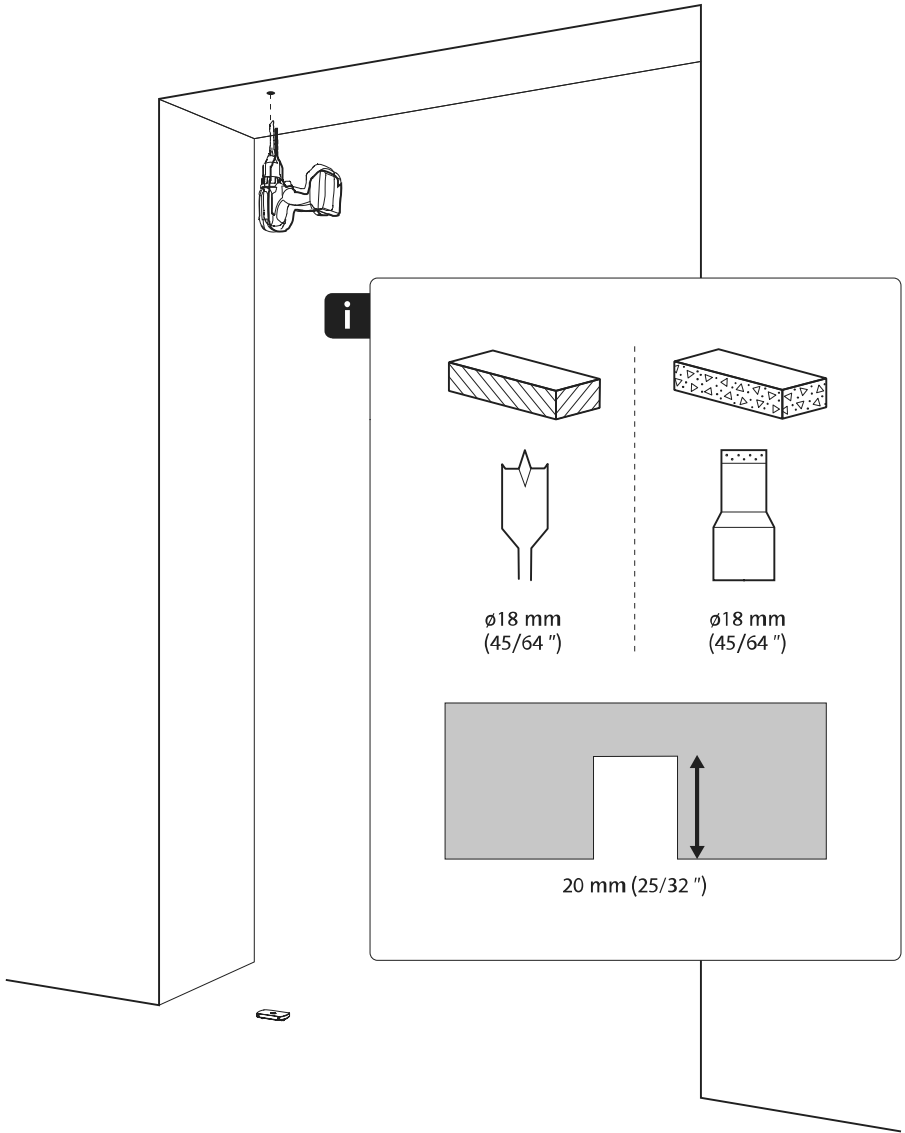



1

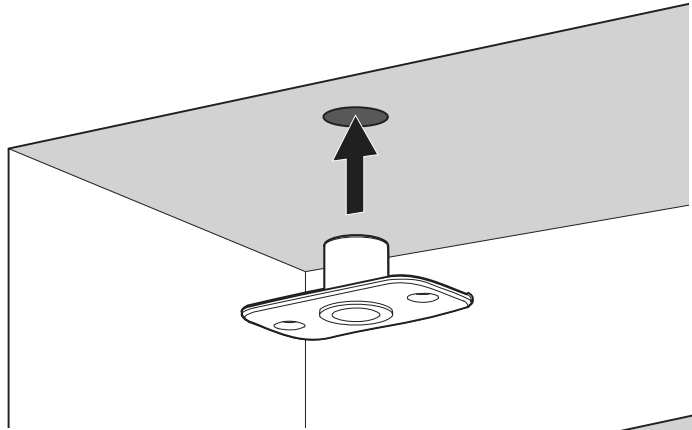

2

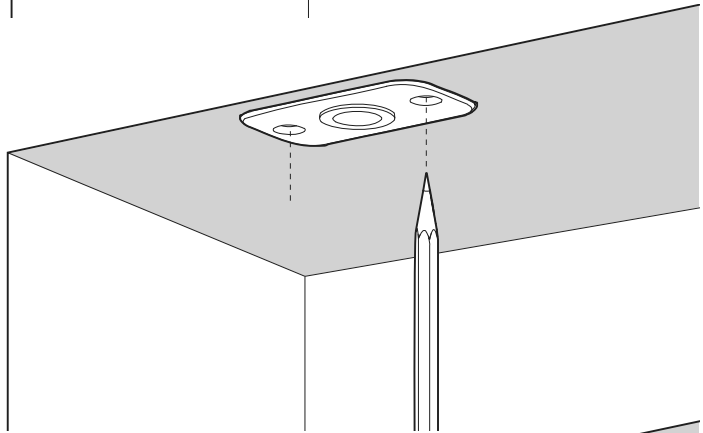

3

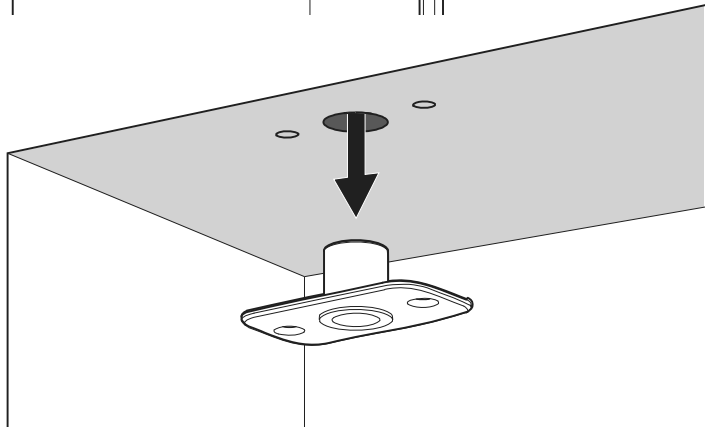



1

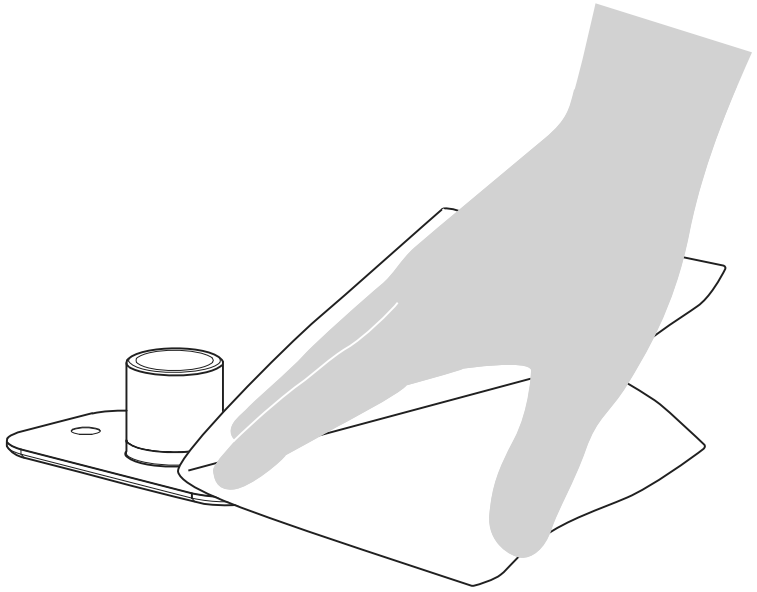

2

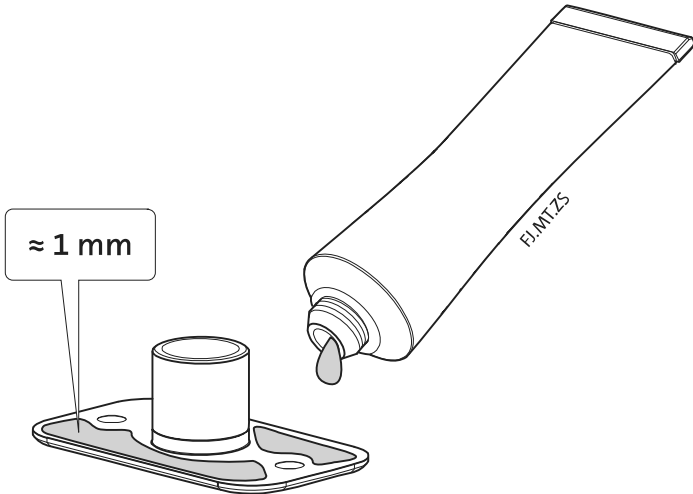

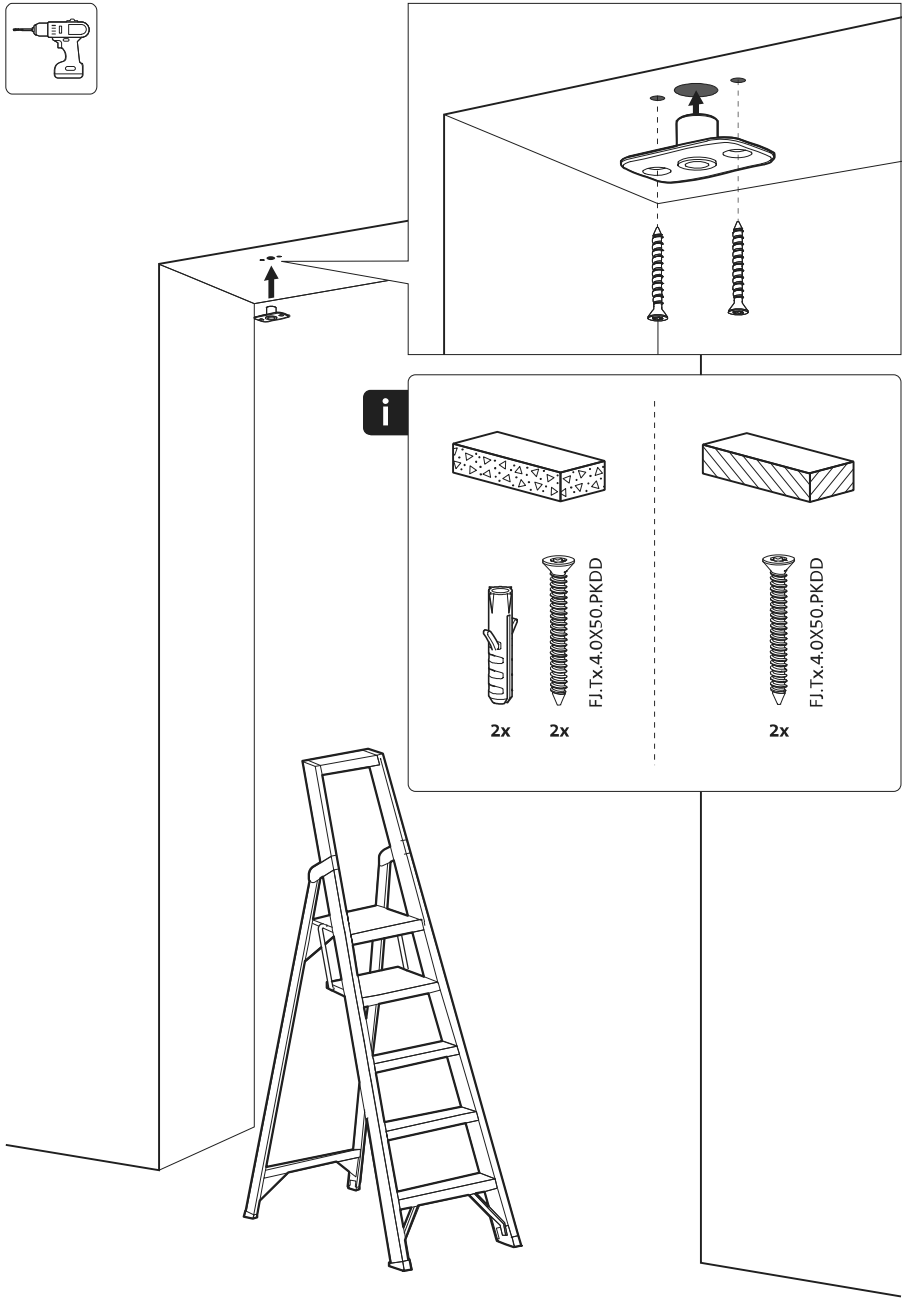

i

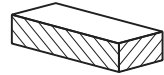
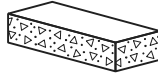

2x



2x

FJ, Tx, 4.0x50, PKDD



2x

FJ, Tx, 4.0x50, PKDD

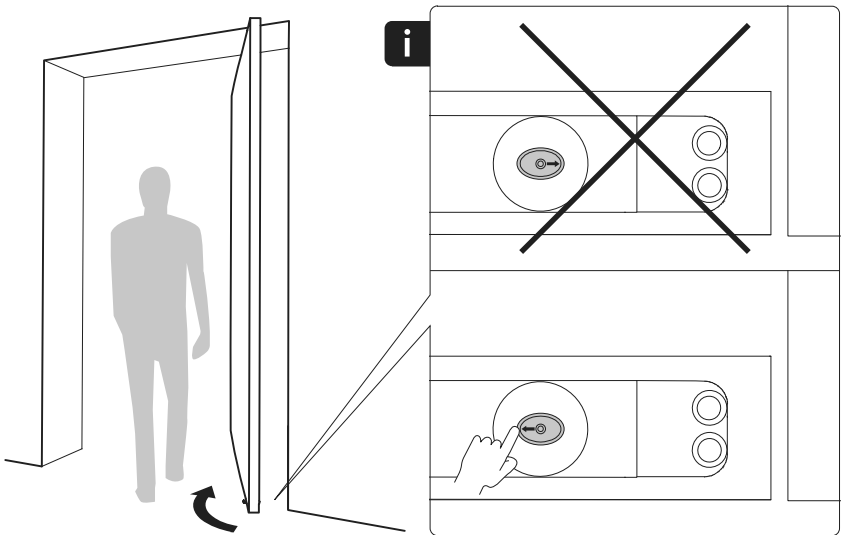
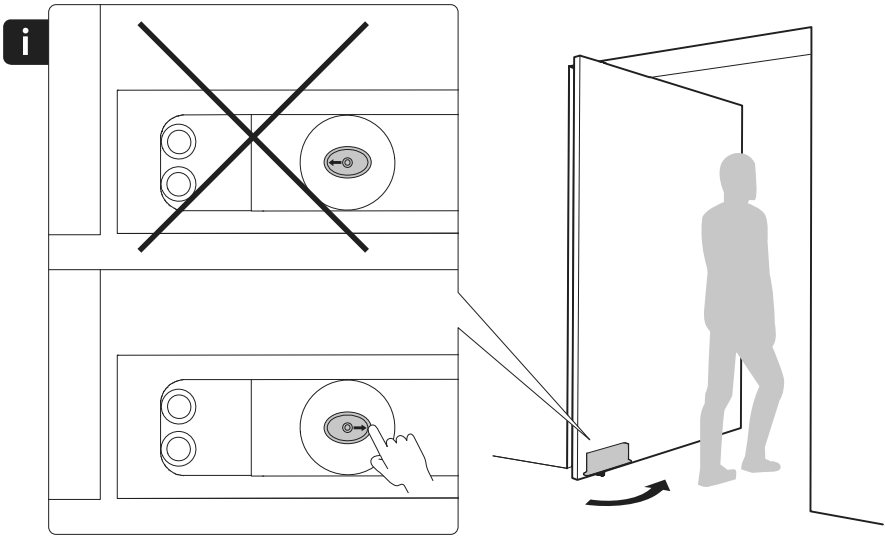

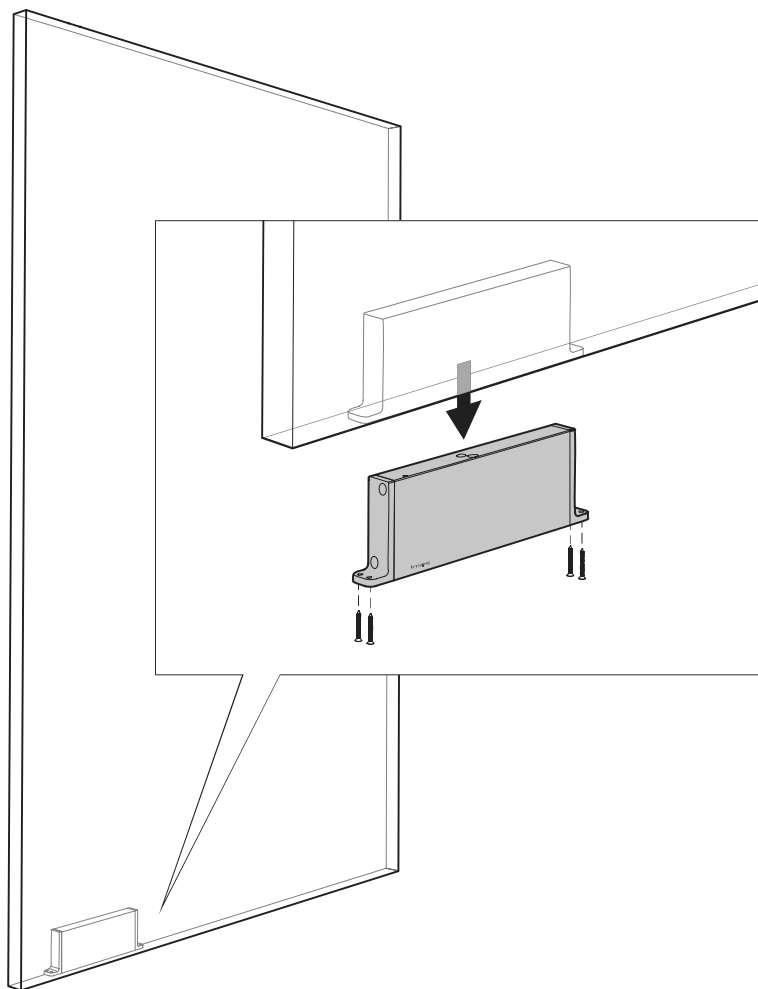

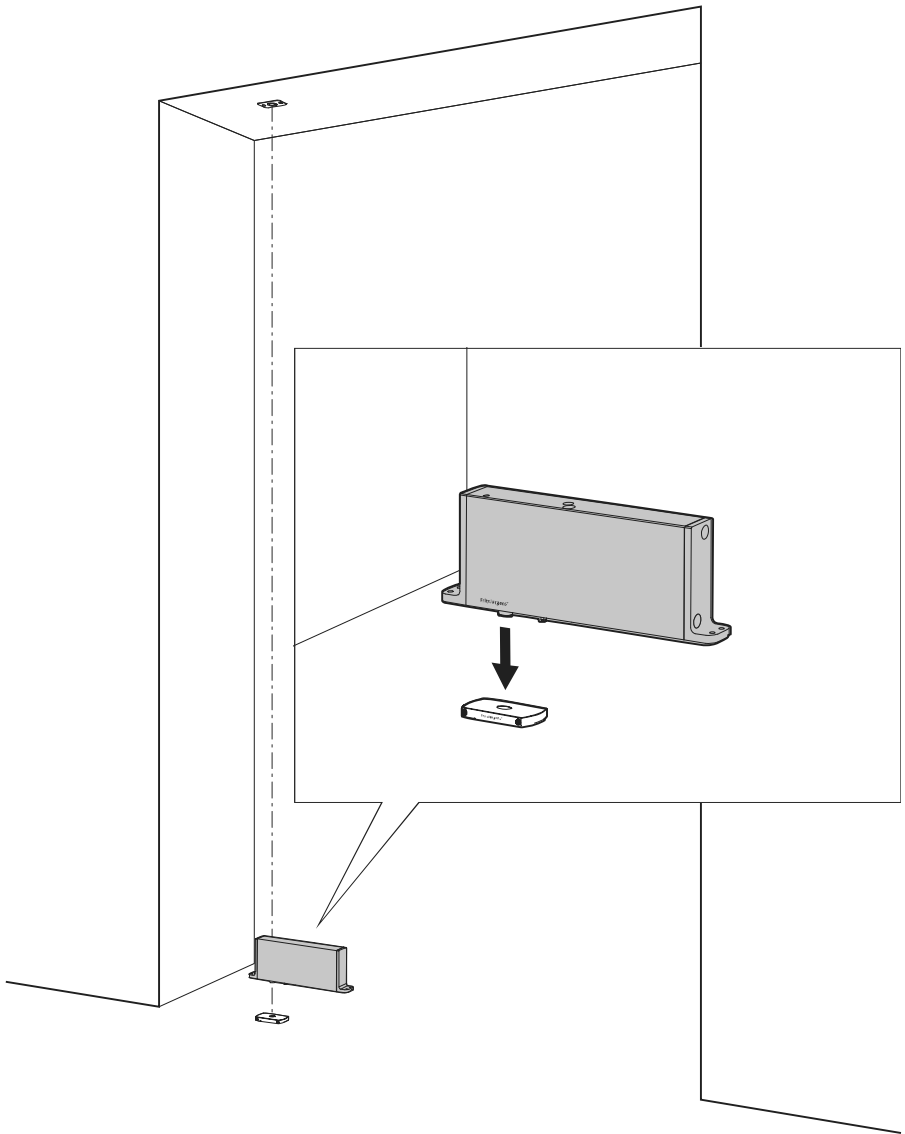

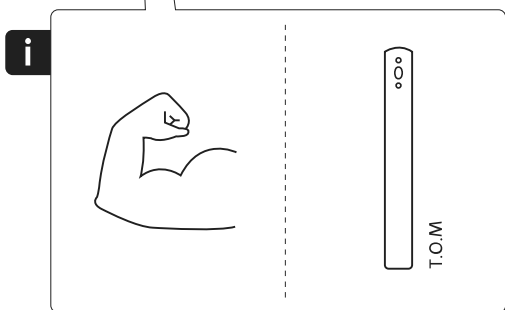
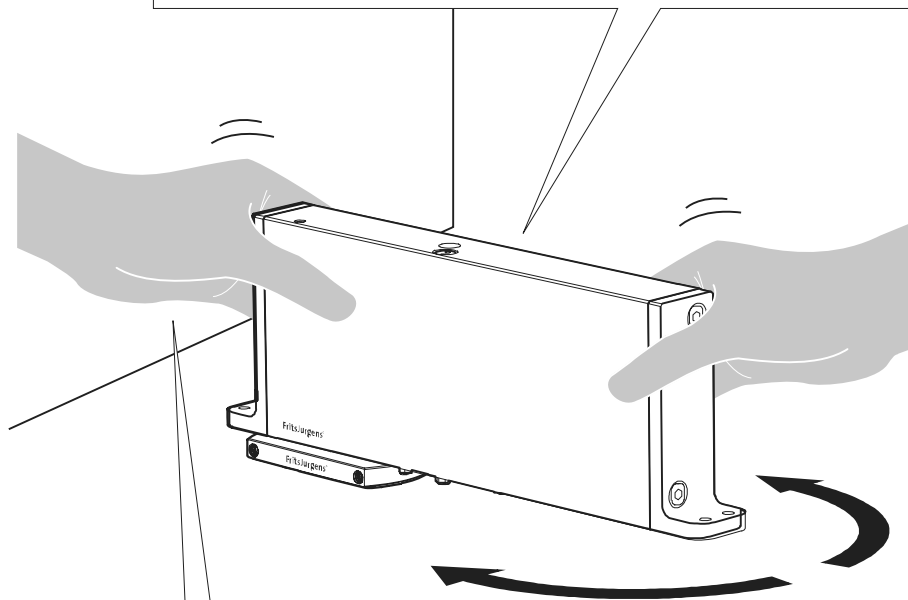
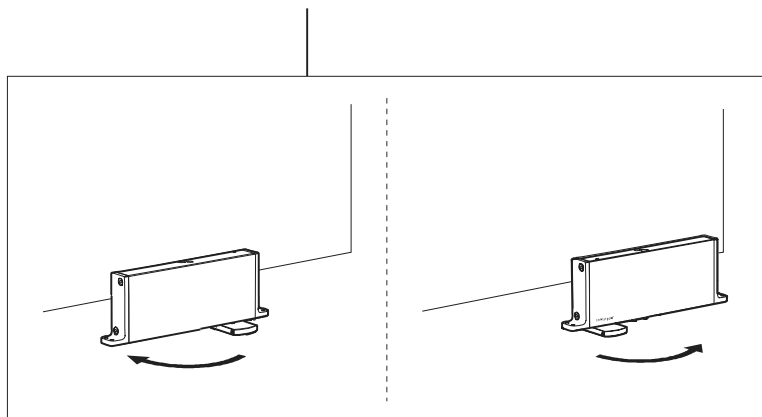

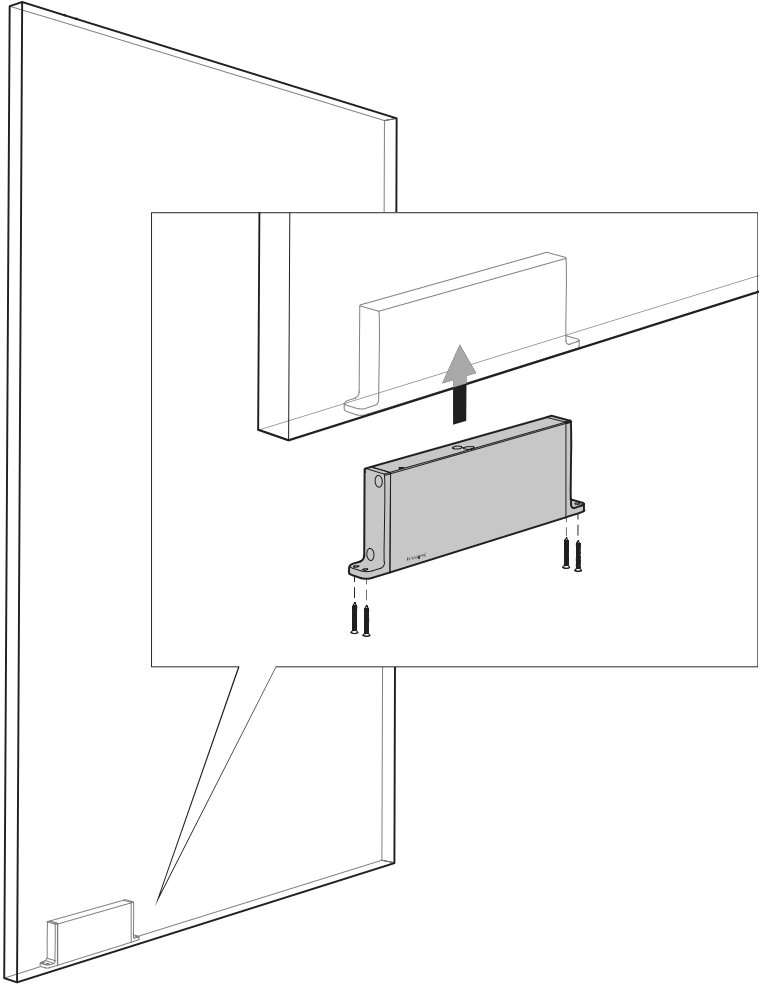

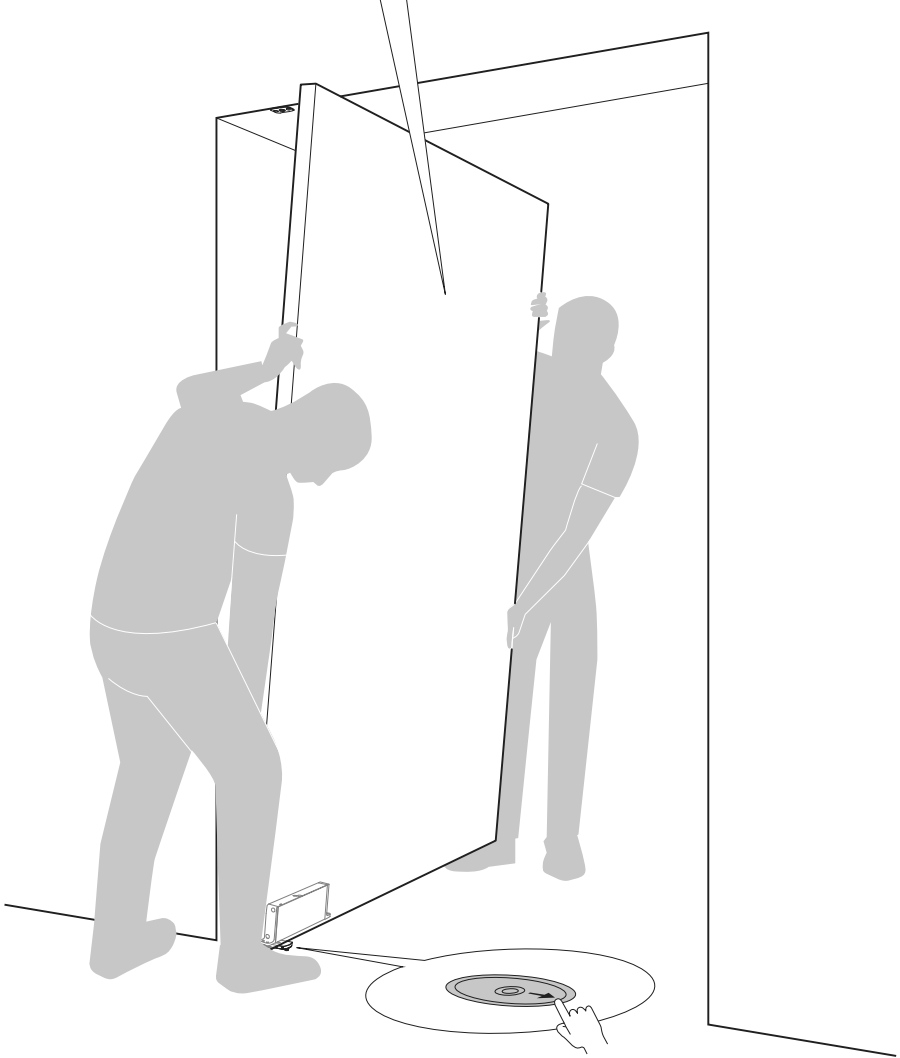
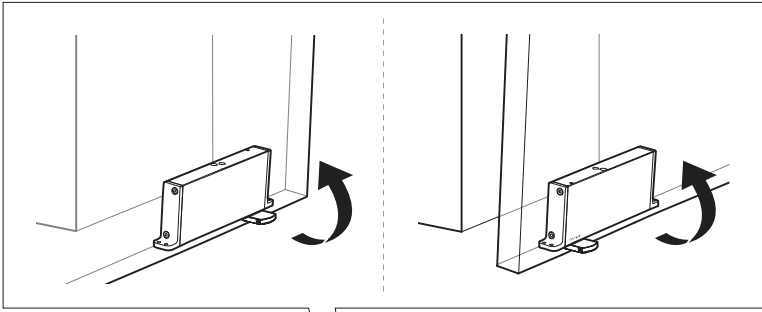

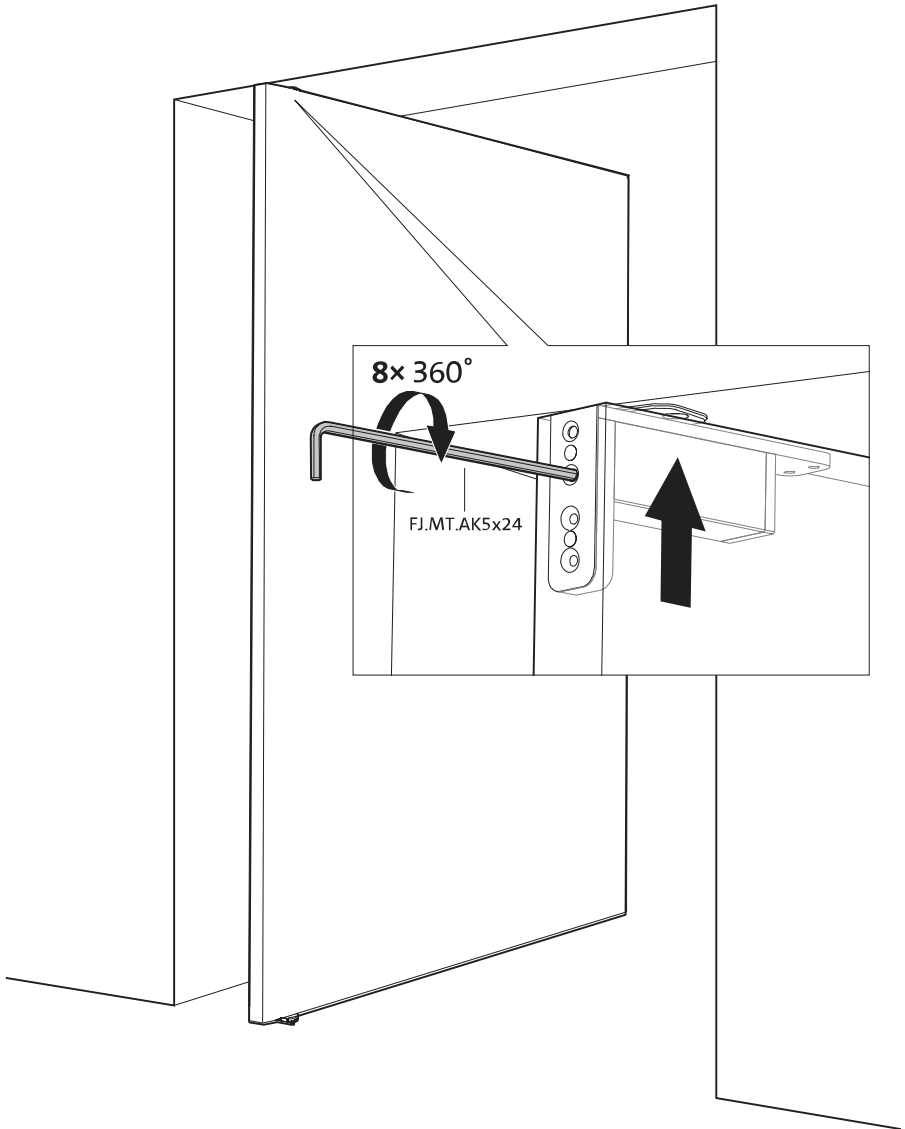
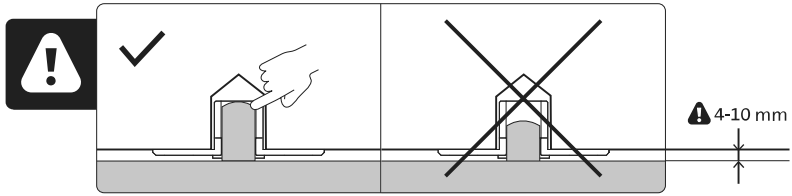

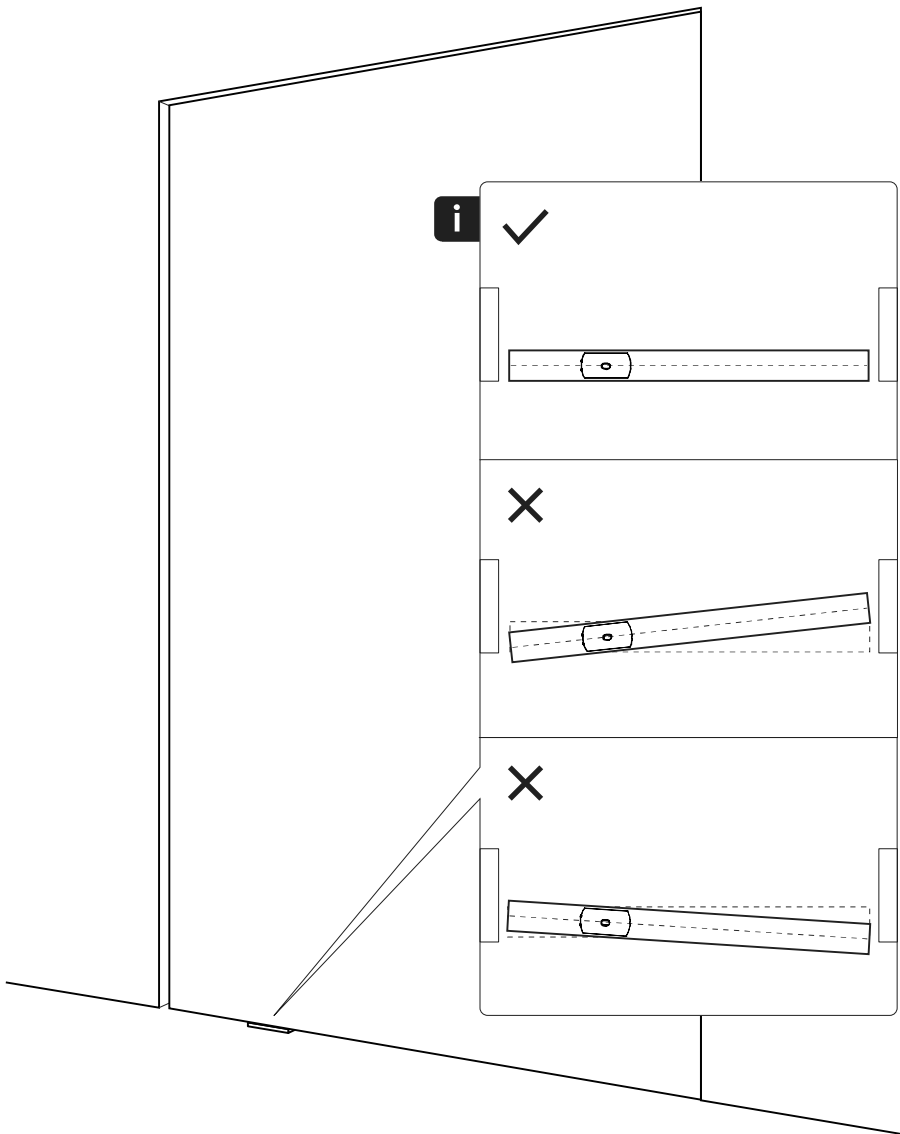

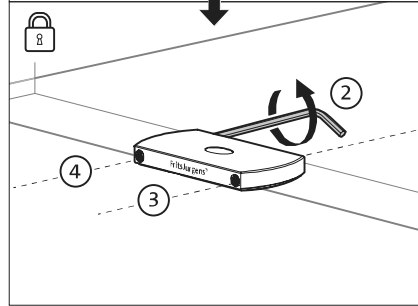
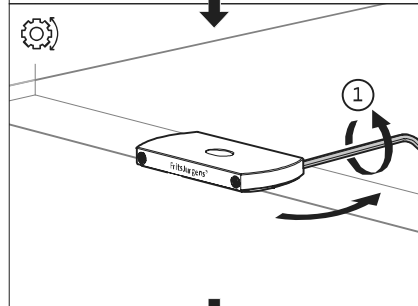
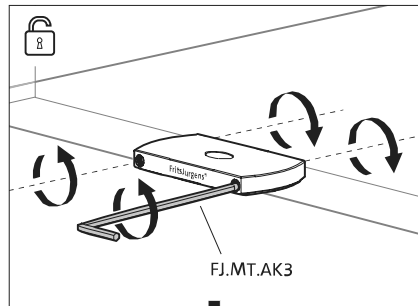
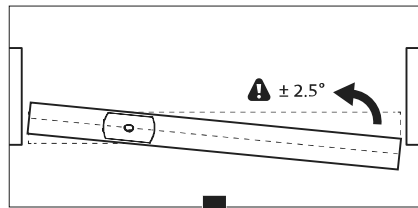
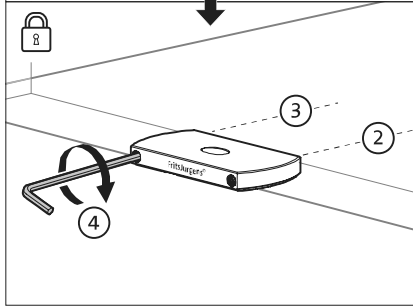
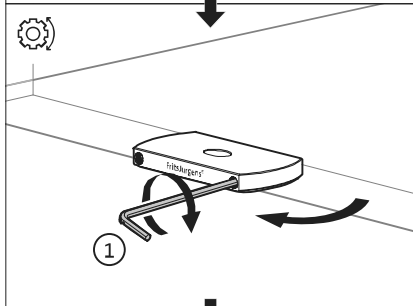
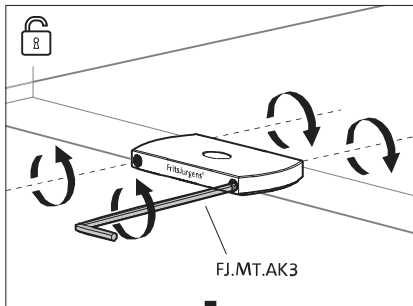
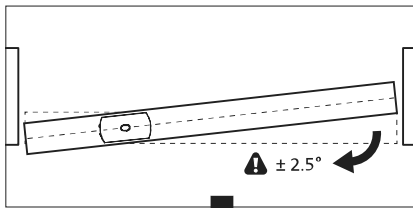

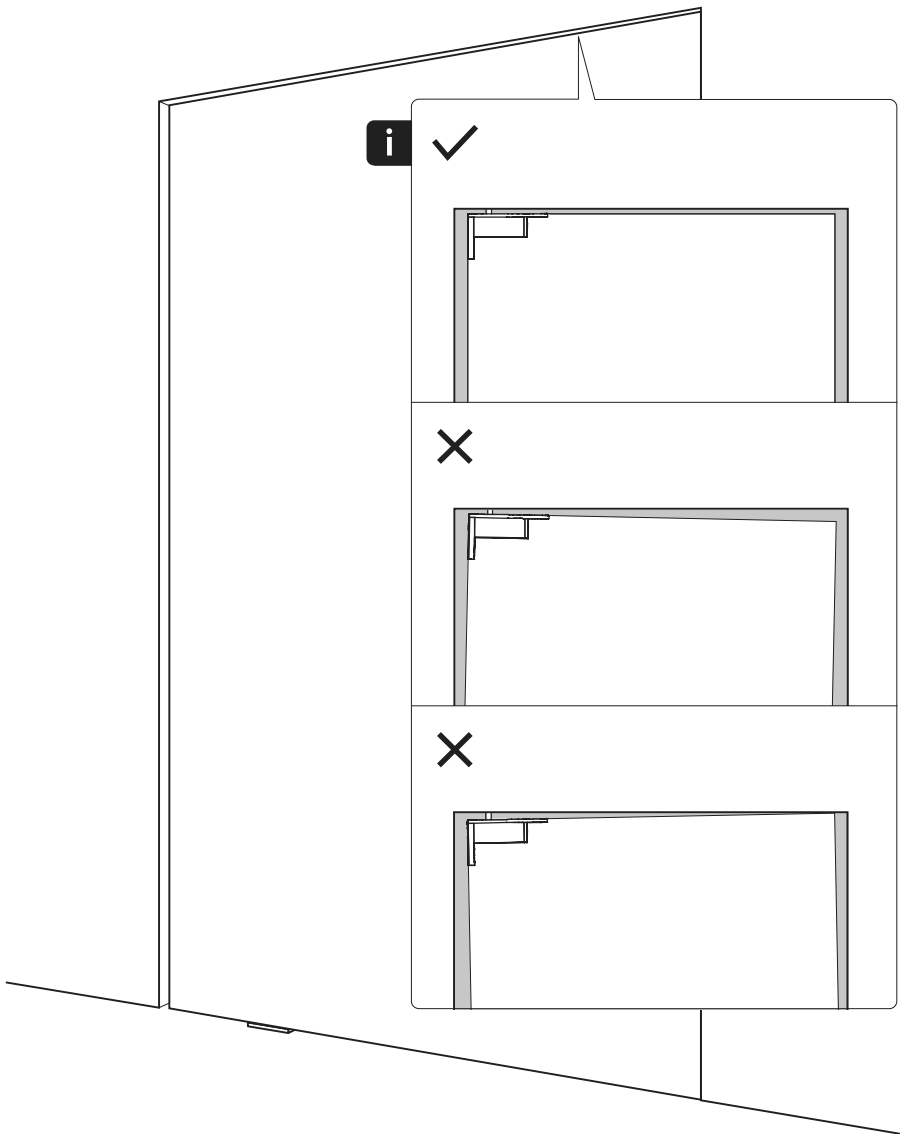

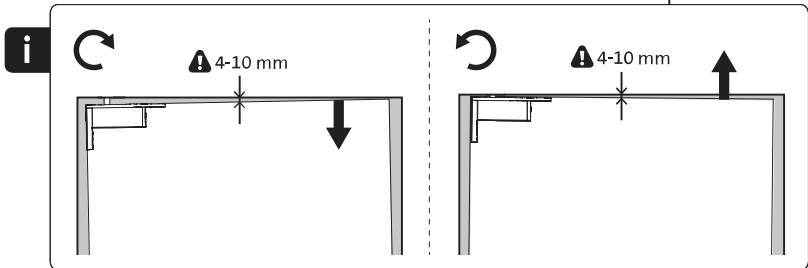
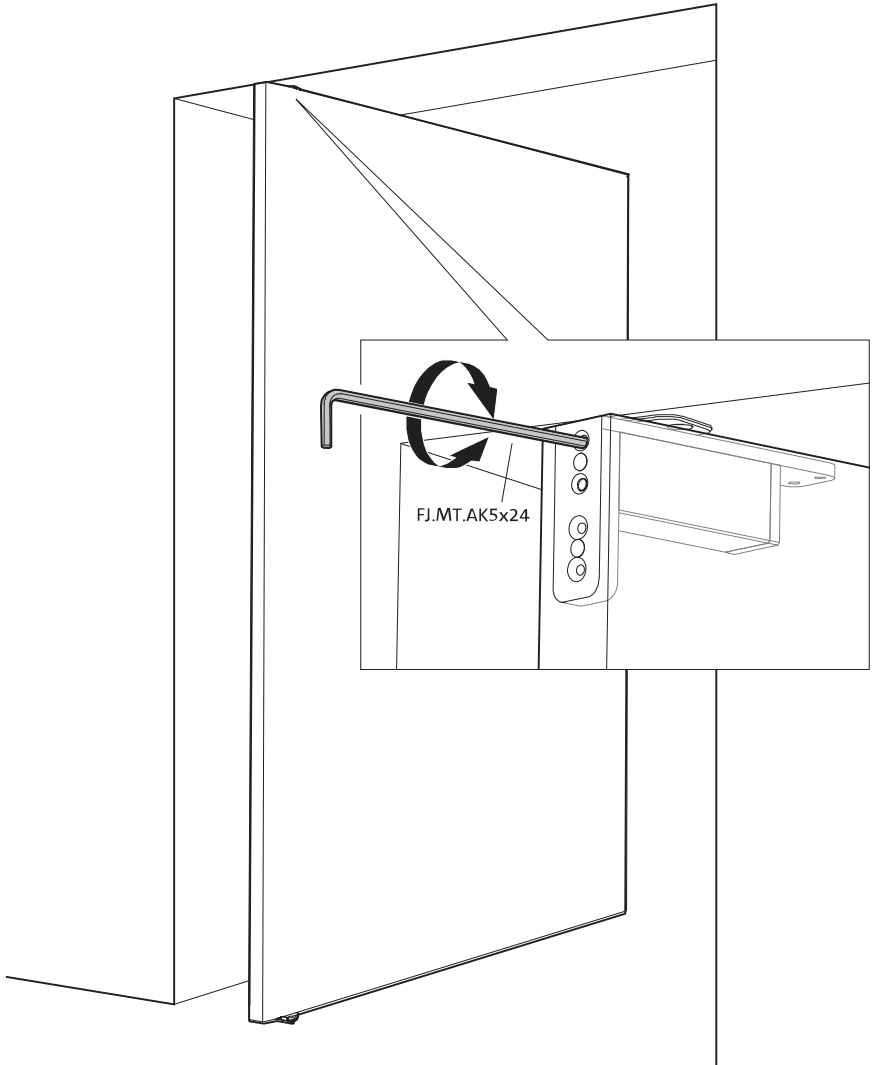

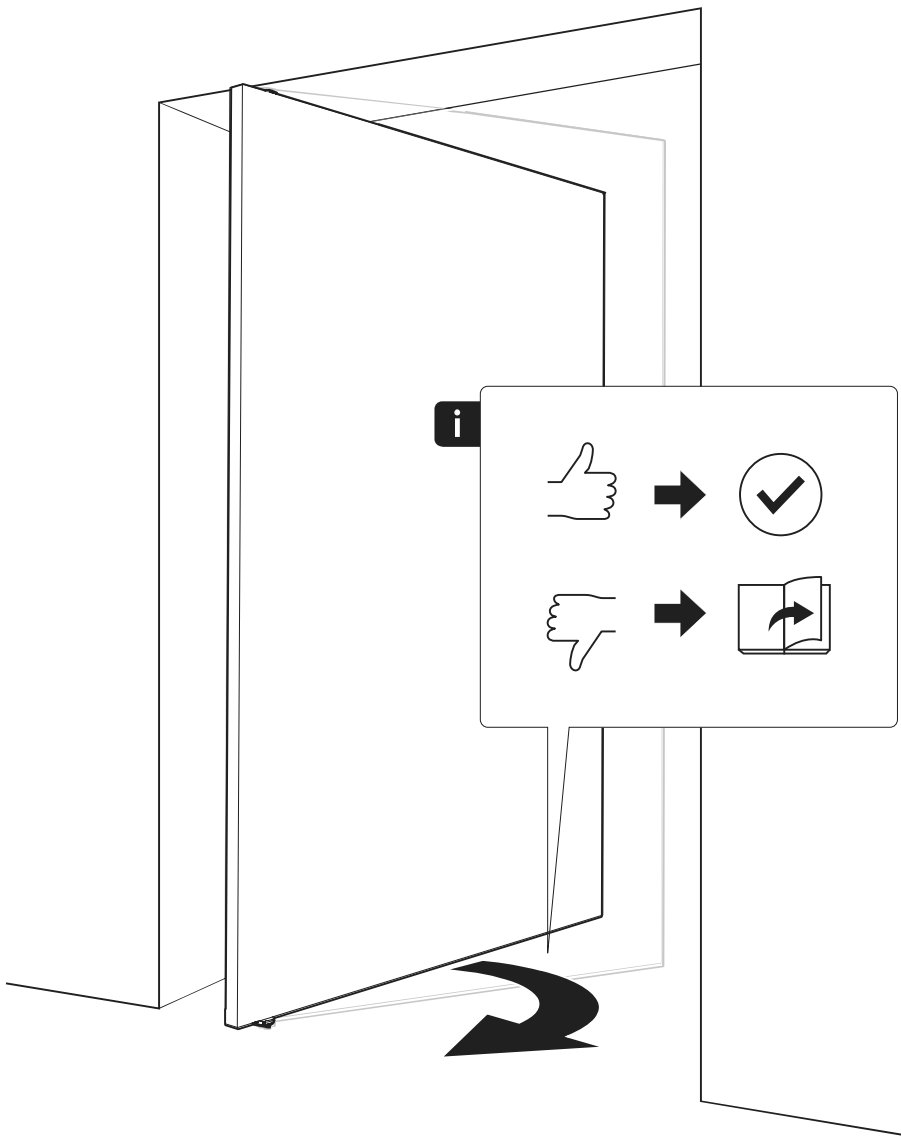



FJ.MT.AC.M+

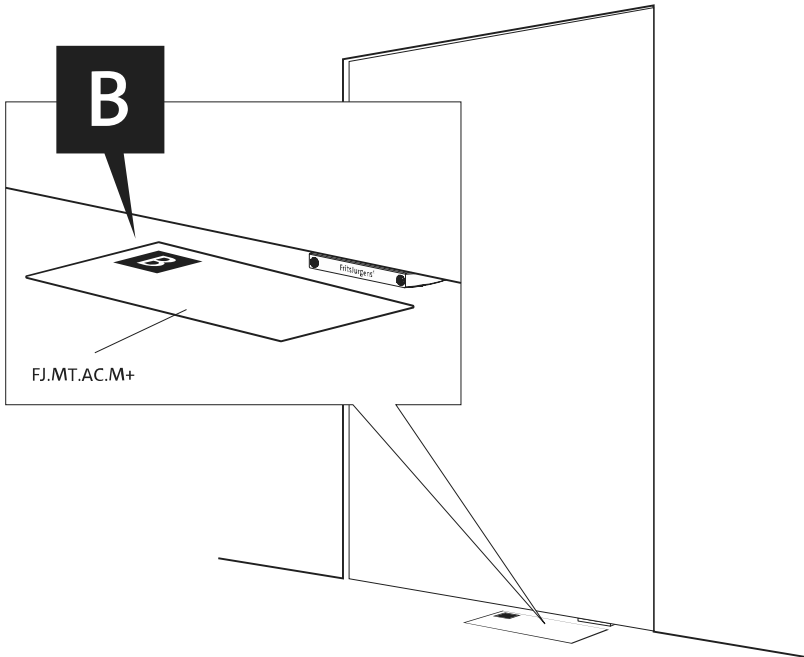
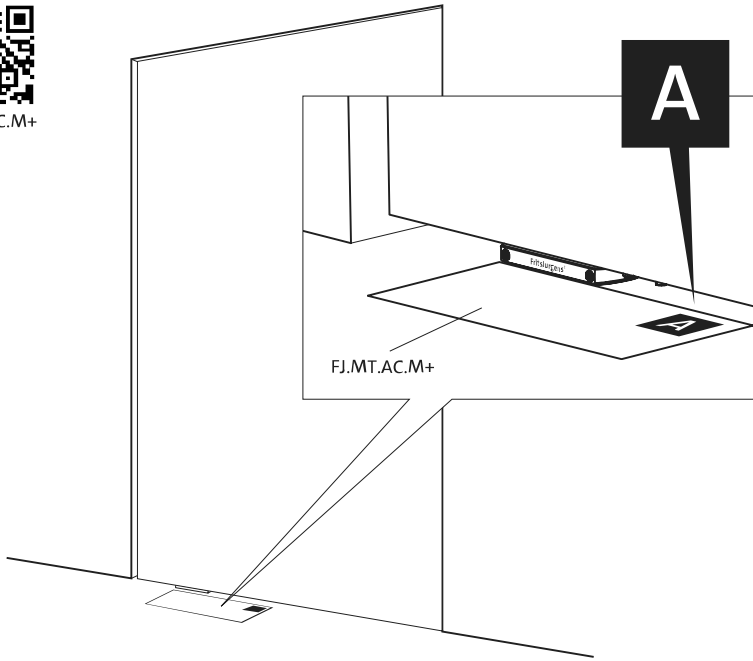

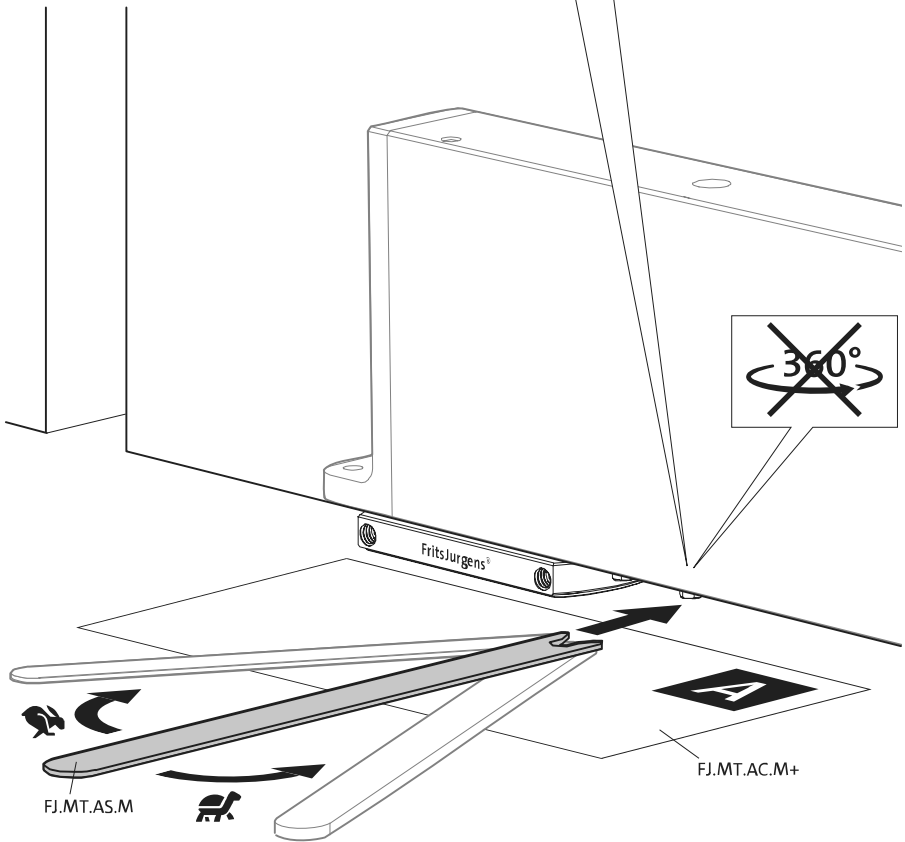
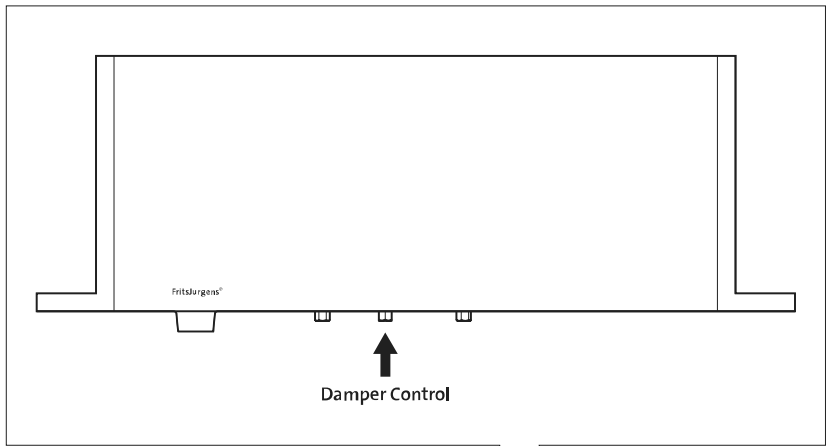

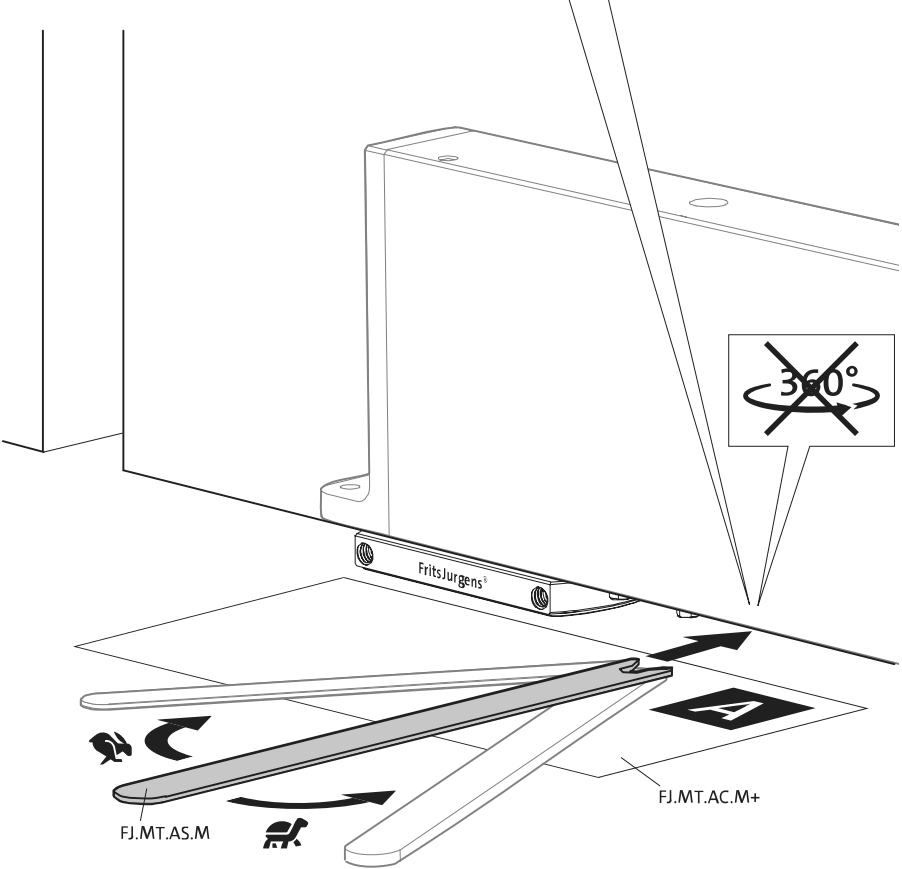
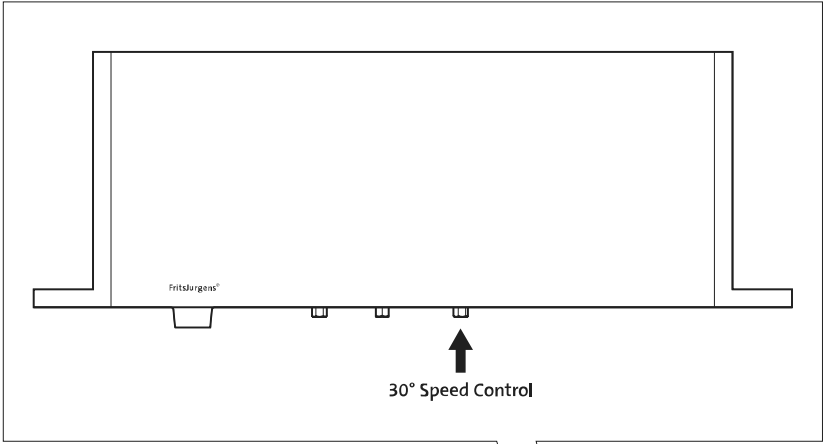

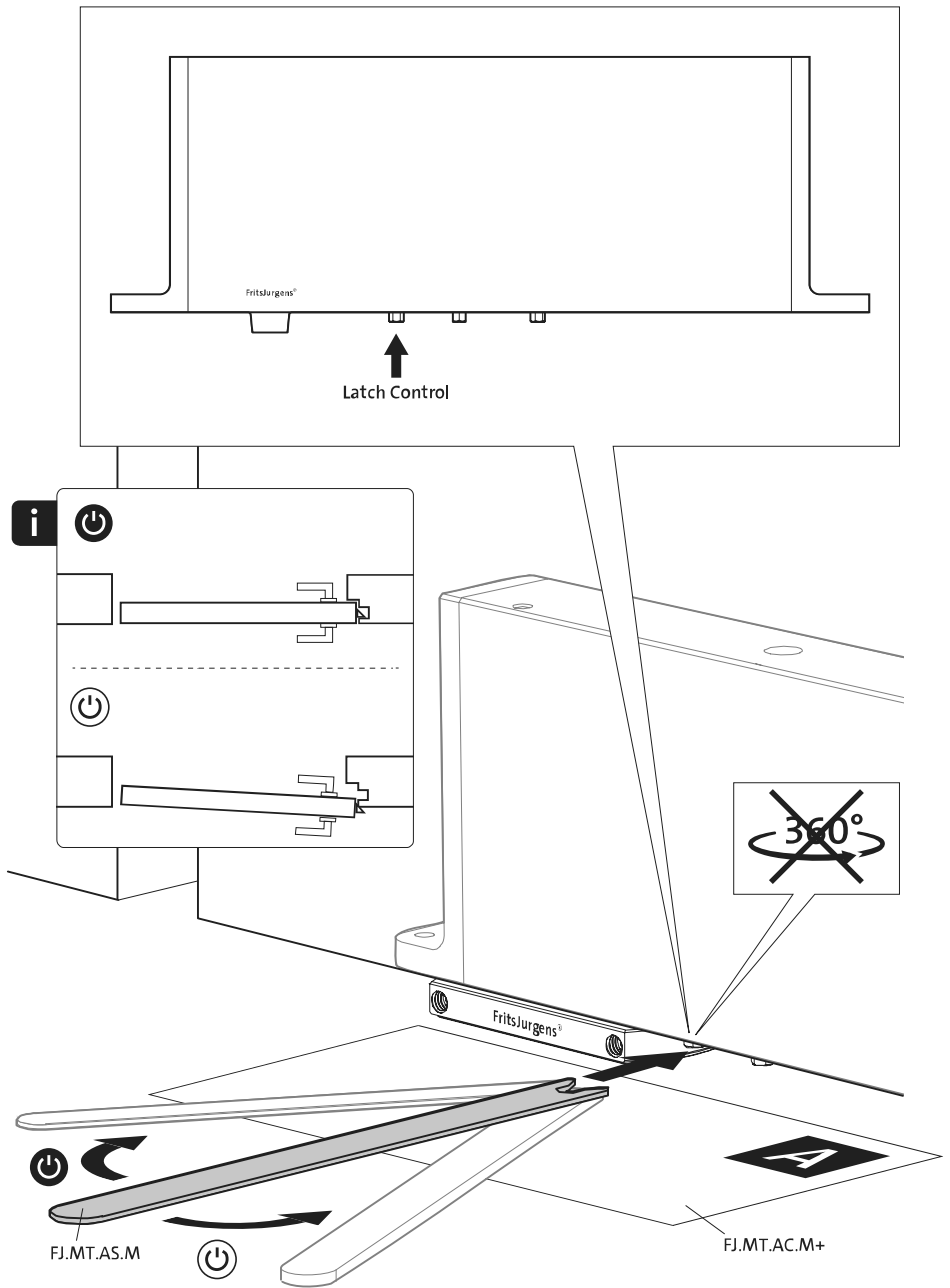

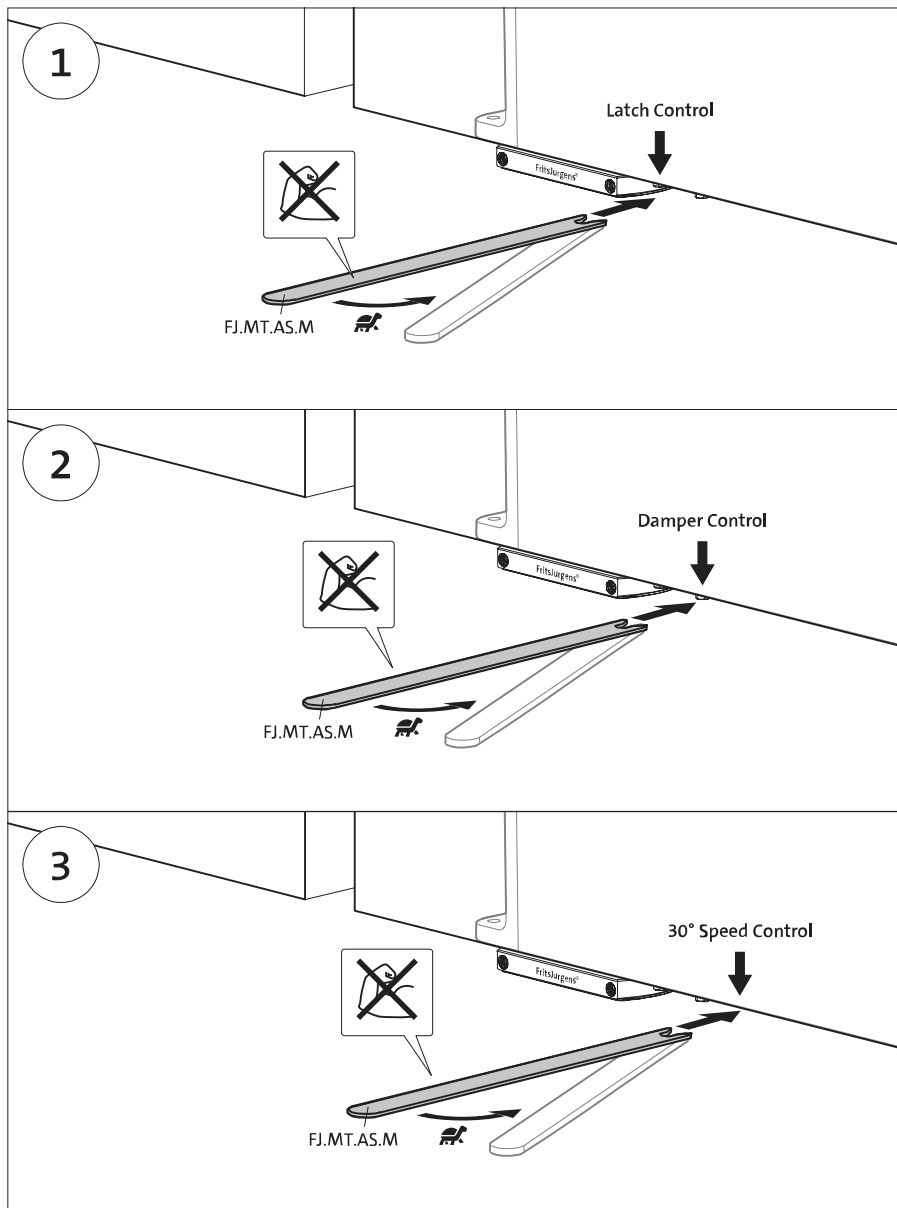

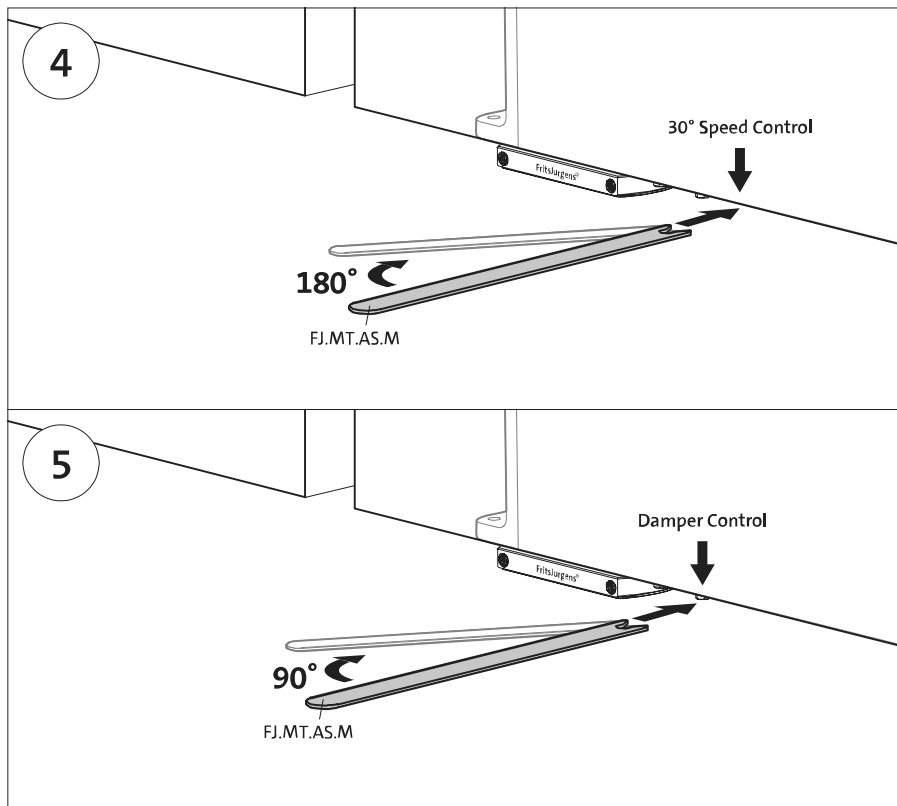

Istruzioni di smontaggio

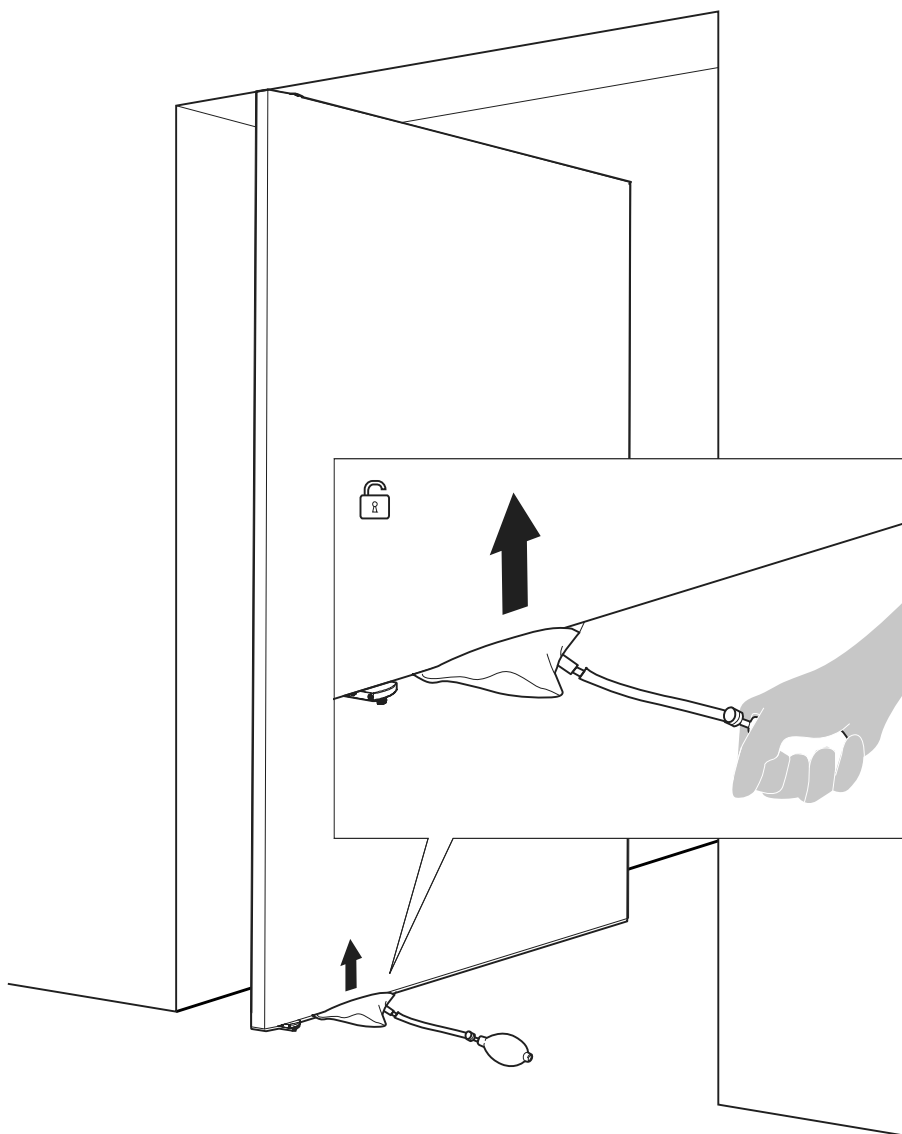

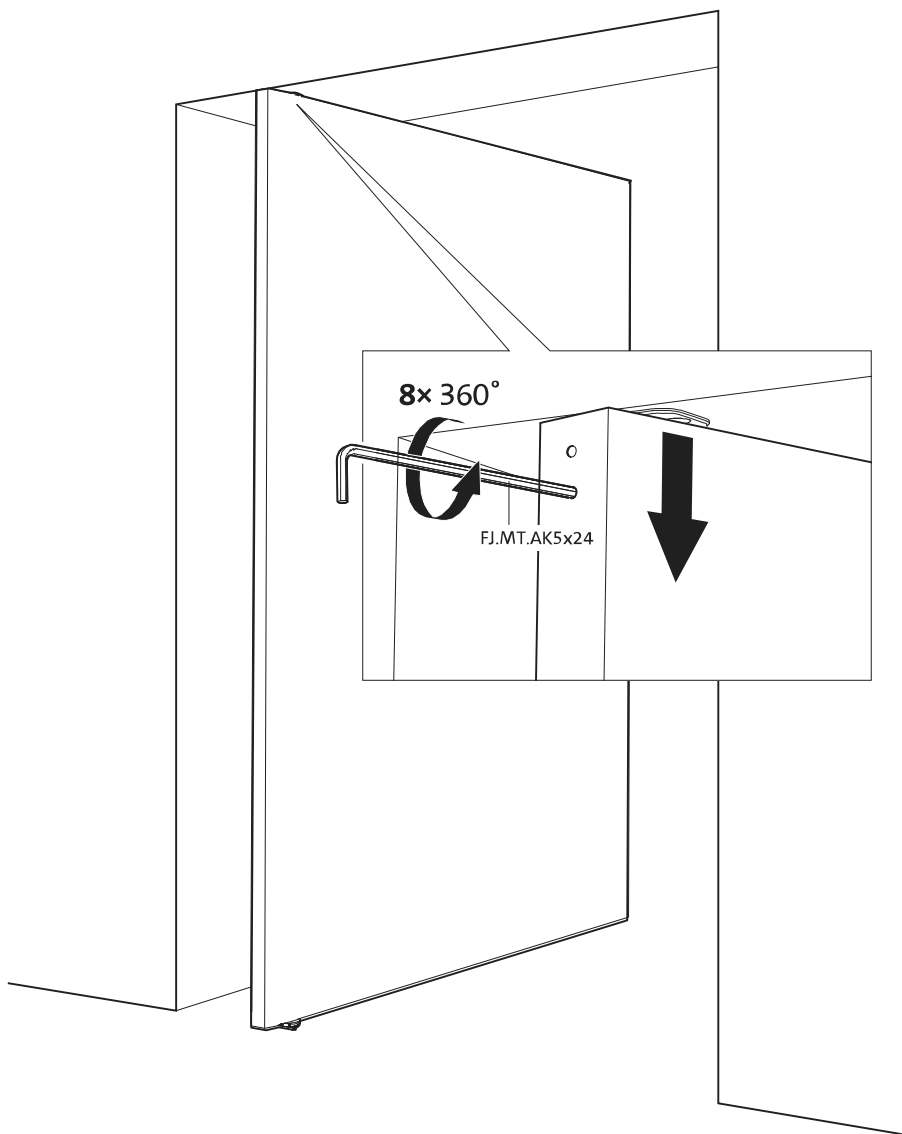



FritsJurgens International

A. Einsteinlaan 1

Paesi Bassi

9615 TE Kolham

+31 598 343 410

info@fritsjurgens.com

FritsJurgens Dubai Branch

DLC-OP-A2-4-0029

Dubai South

Dubai

Emirati Arabi Uniti

+971 4 820 8106

+971 58 137 2611

dubai@fritsjurgens.com

fritsjurgens.com

Copyright © FritsJurgens®
BPM+.40.C.X.SS



