

# System M+

## Manuale di fresatura e montaggio

FritsJurgens Kit - 70 mm Classe C - invisibile

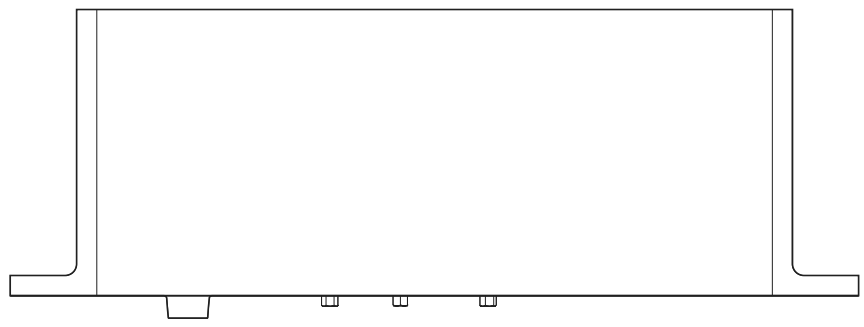



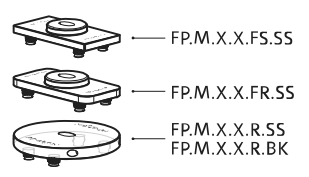
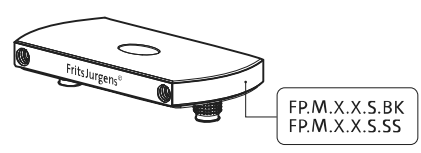
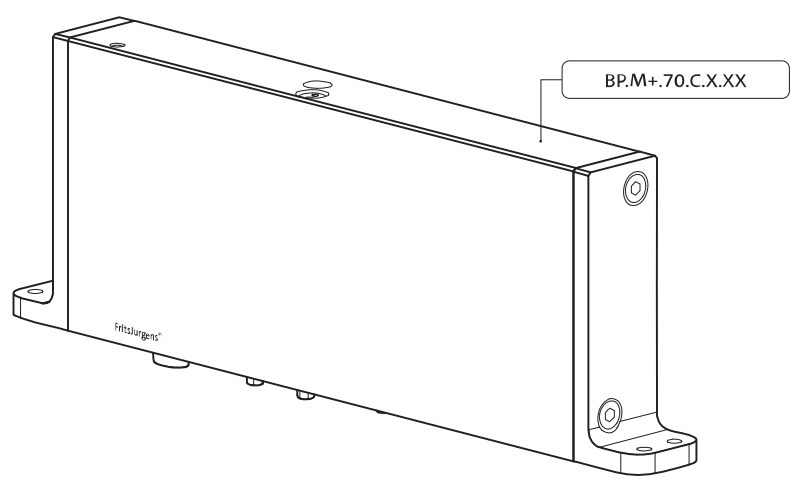
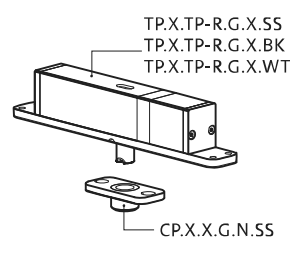
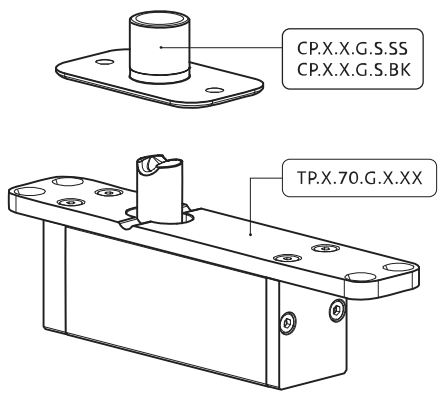



# Istruzioni di fresatura

# BP.M+.70.C.X.XX

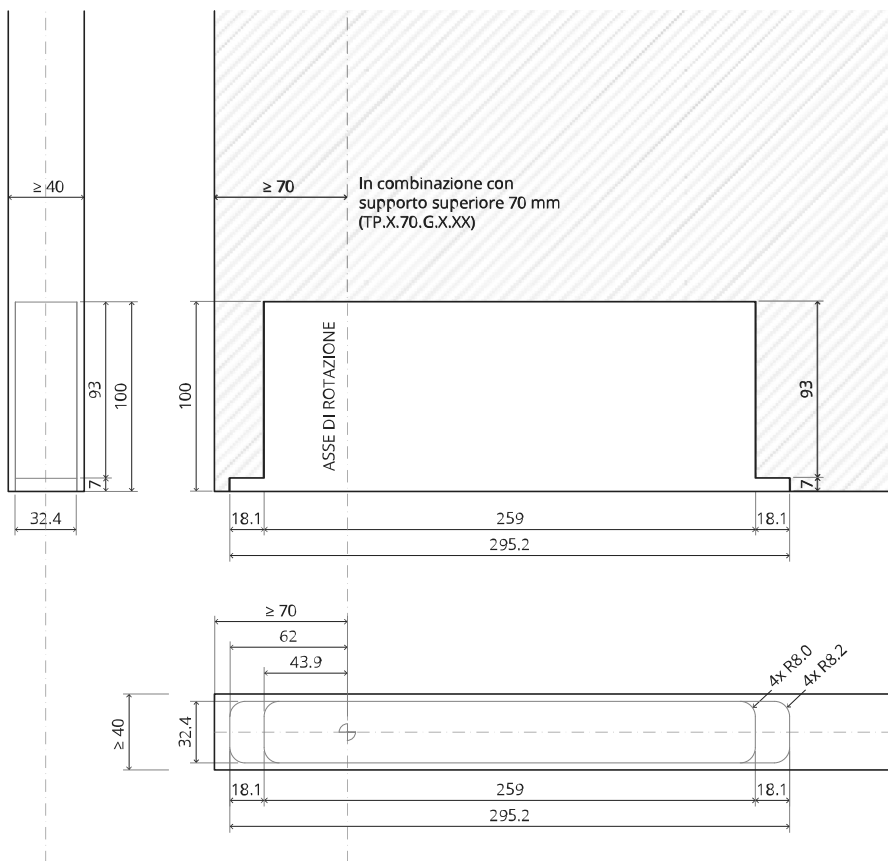

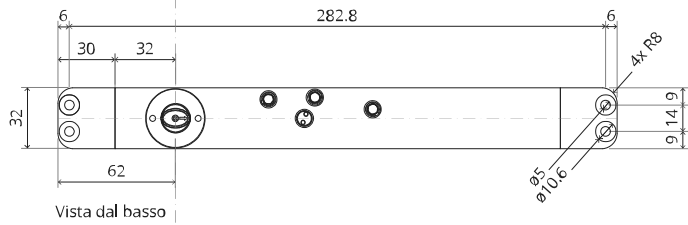
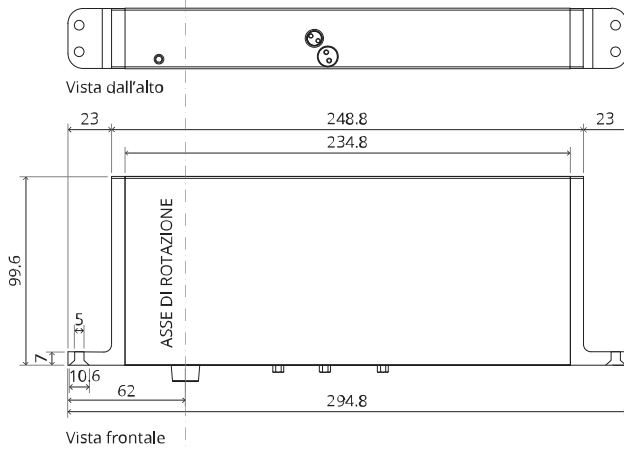
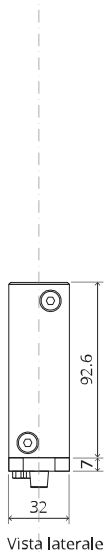

# TP.X.70.G.X.XX

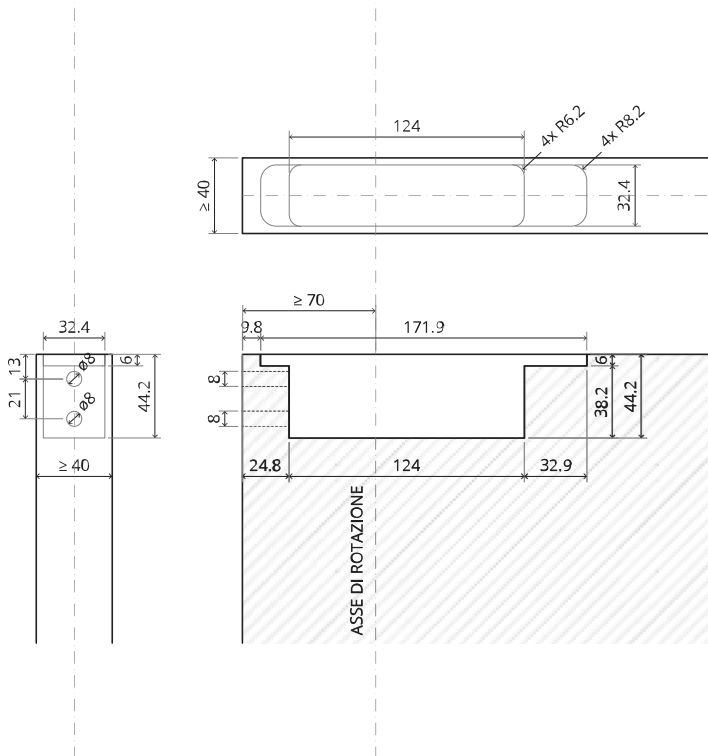



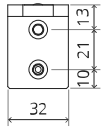

Vista laterale A con perno rivolto verso l'interno

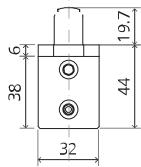

Vista laterale A con il perno rivolto verso l'esterno

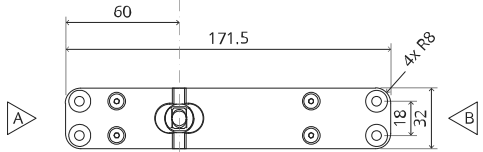

Vista dall'alto

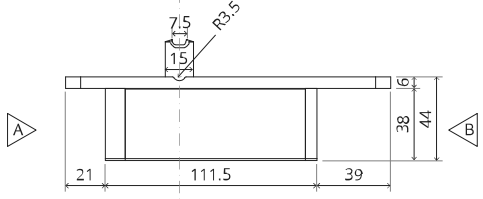

Vista frontale

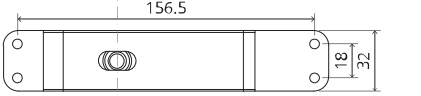

Vista dal basso

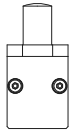

Vista laterale B

# TP.X.TP-R.G.X.

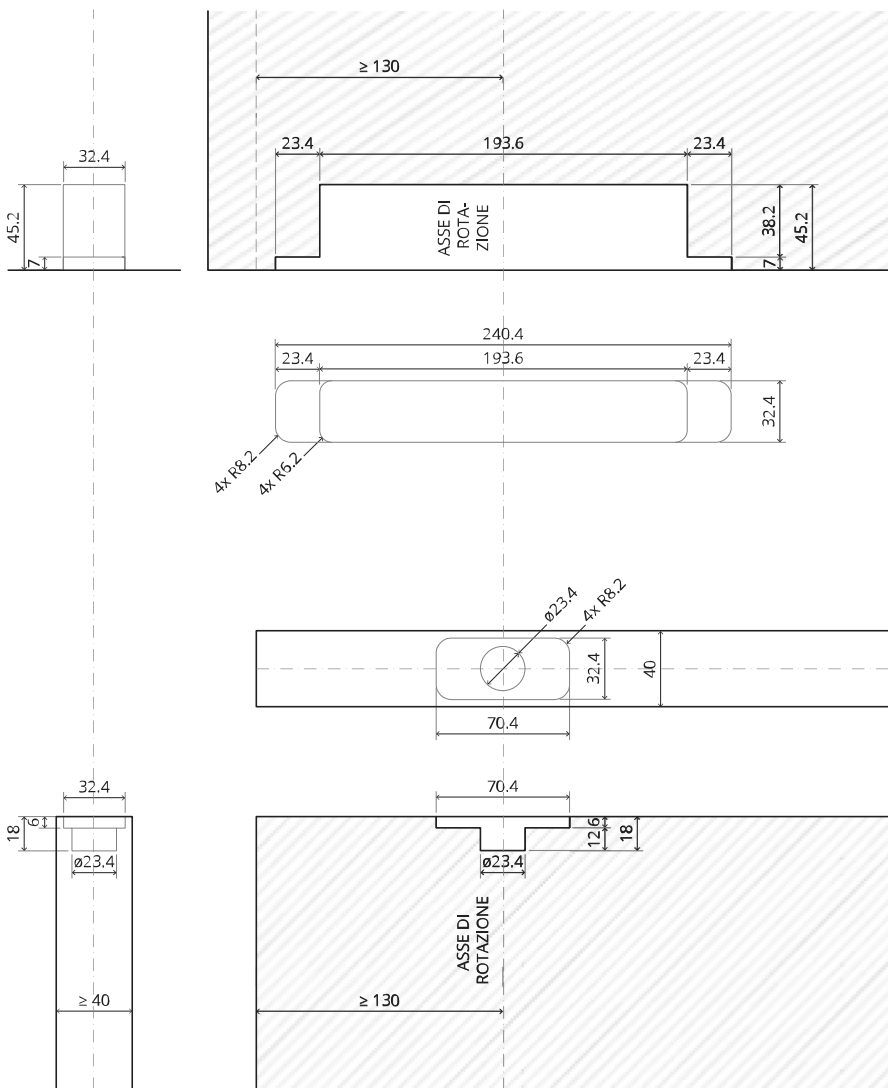

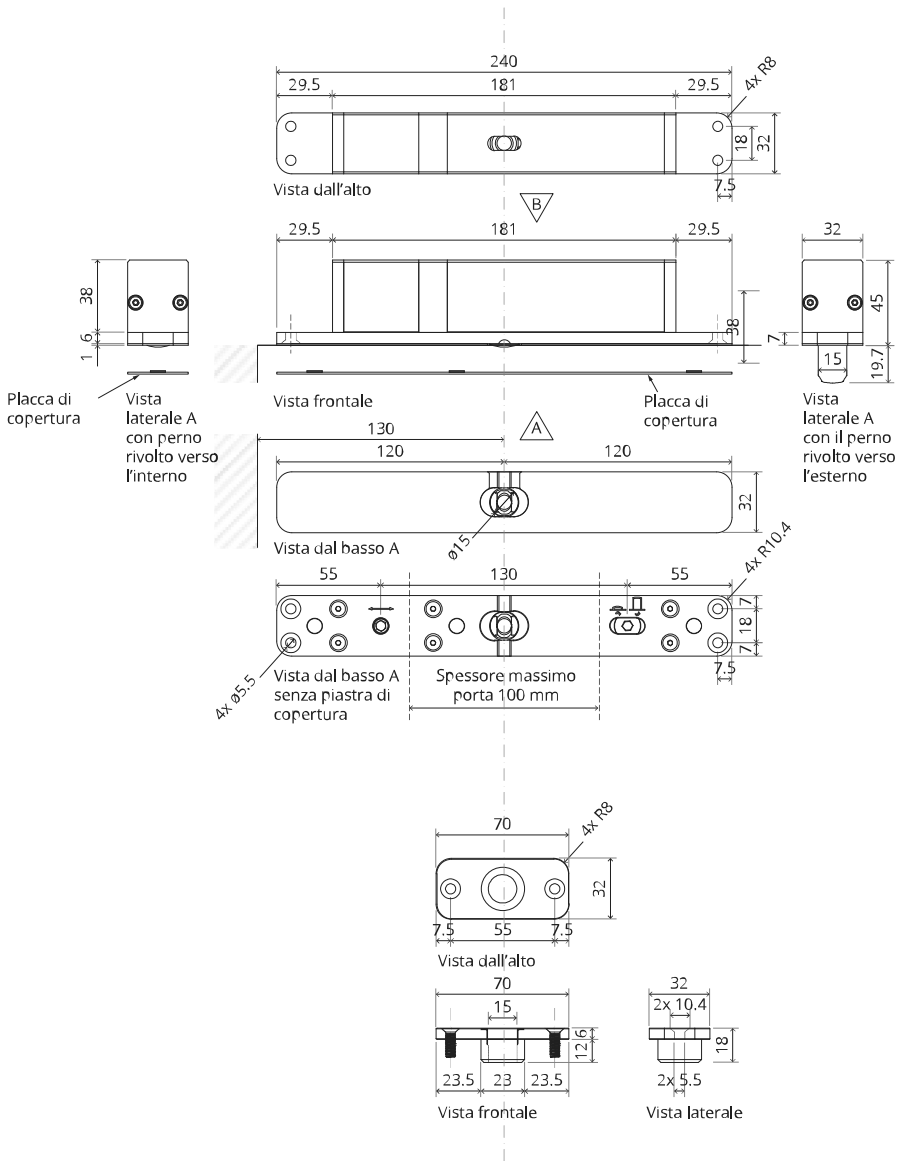

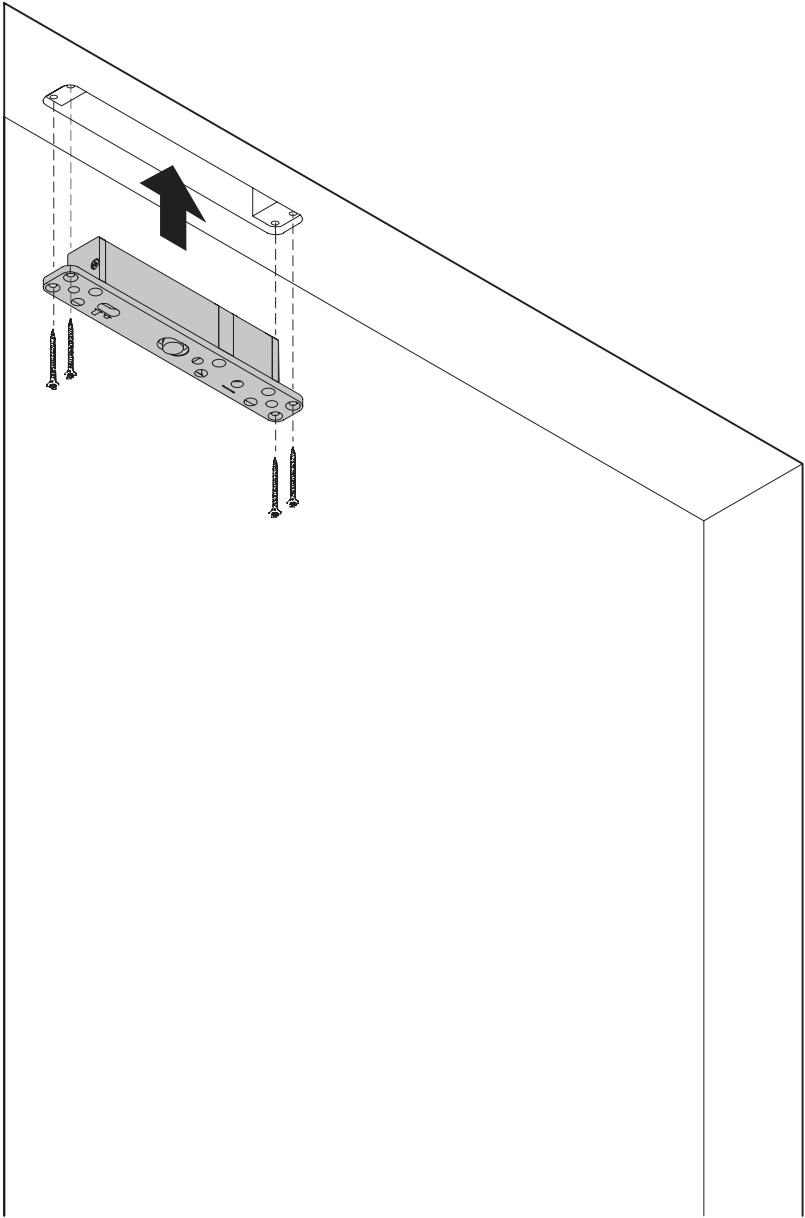

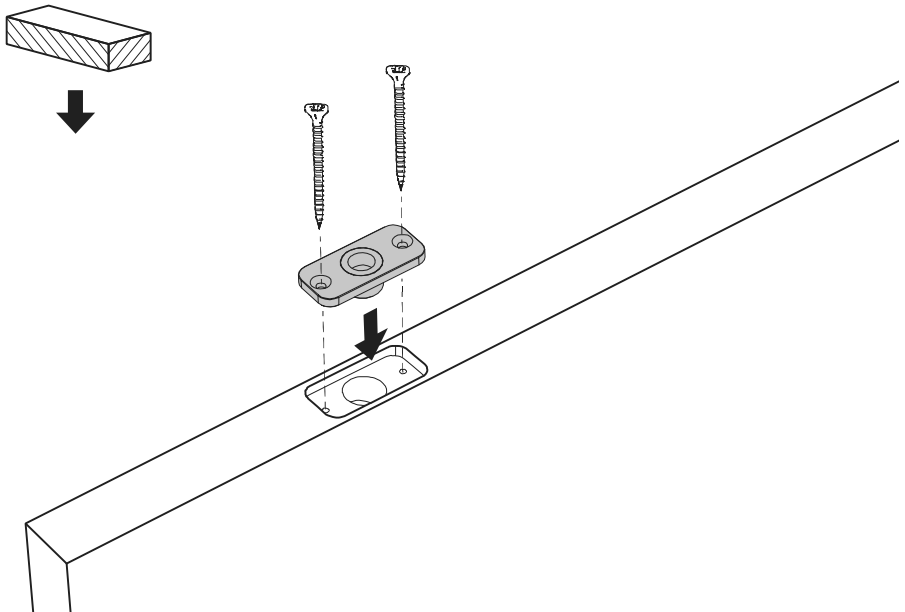
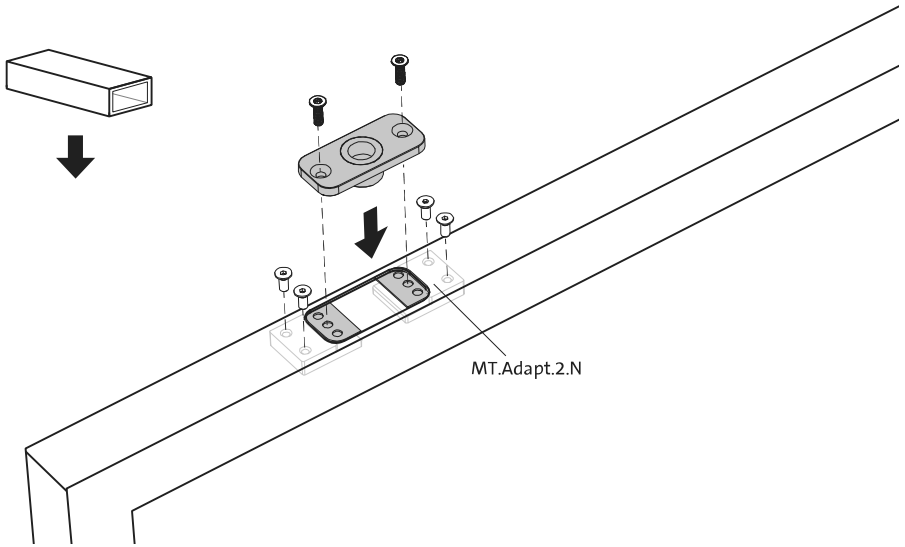

# FP.M.X.X.FS.SS

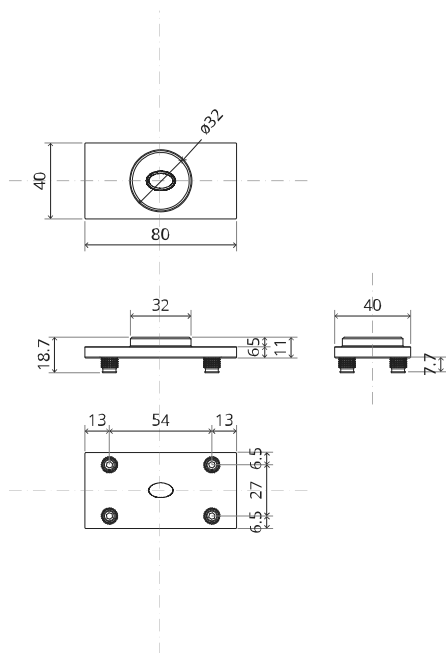
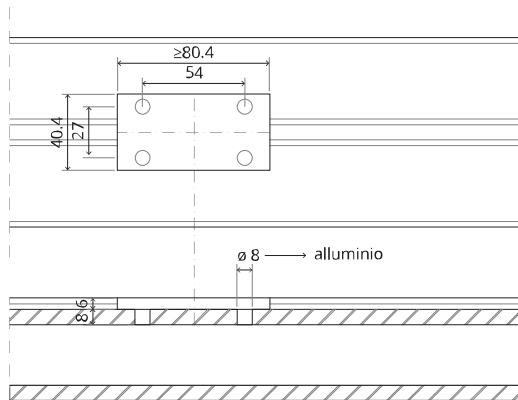

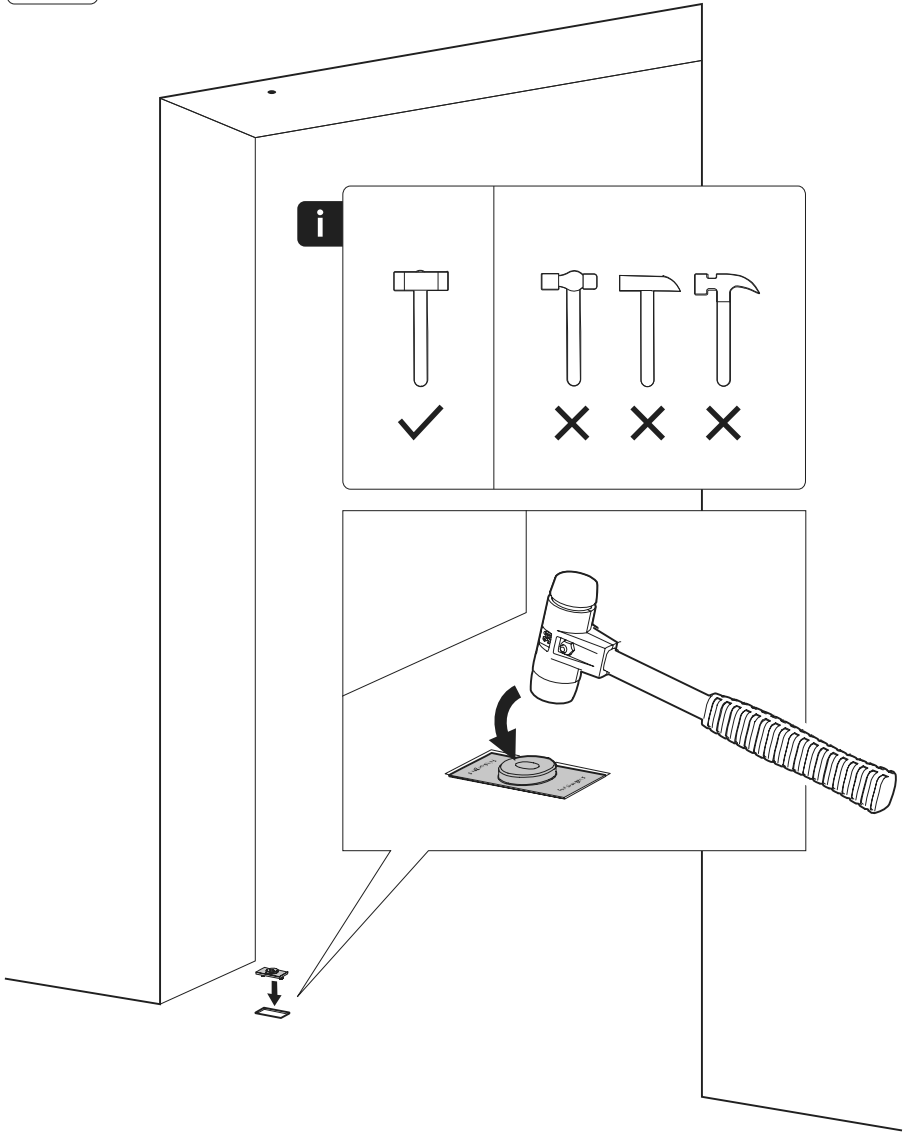

# FP.M.X.X.FR.SS

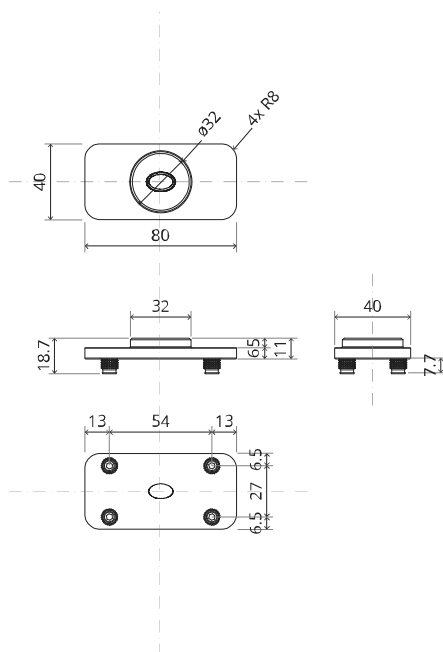
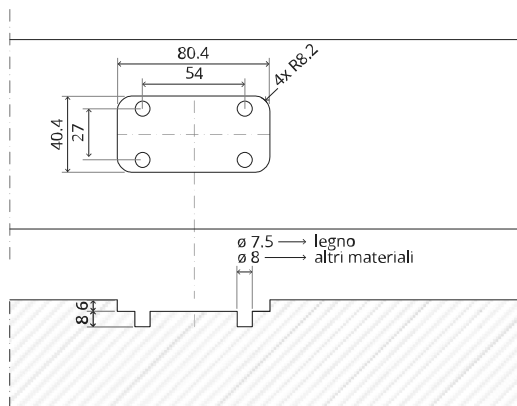



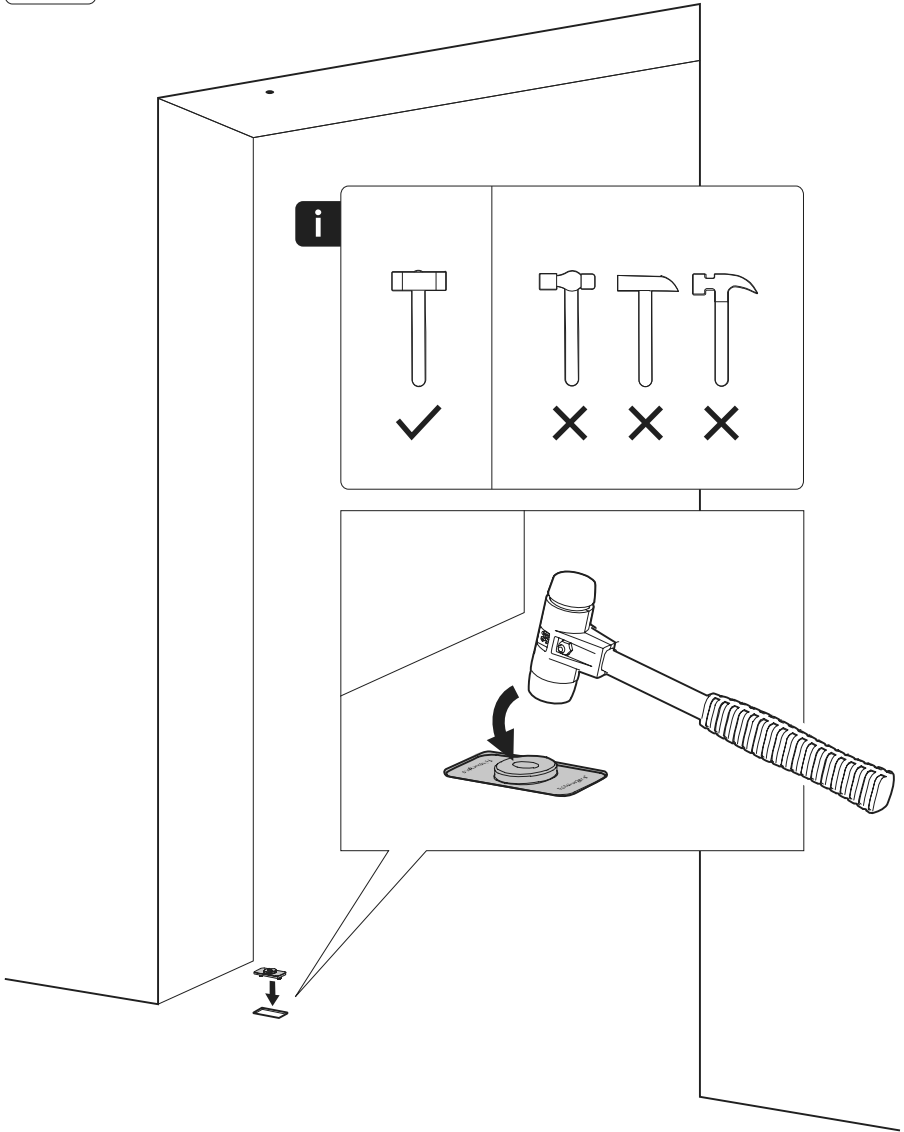



# Istruzioni di montaggio

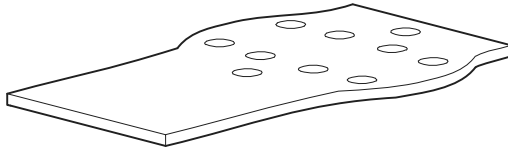

FJ.MT.DT.M

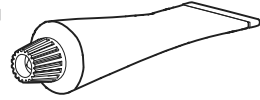

FJ.MT.Z5



10x FJ.Tx.4.0X50.PKDD



FJ.Bit.Tx20

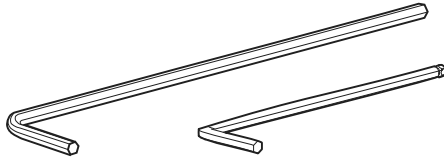

FJ.MT.AK3

FJ.MT.AK5x24

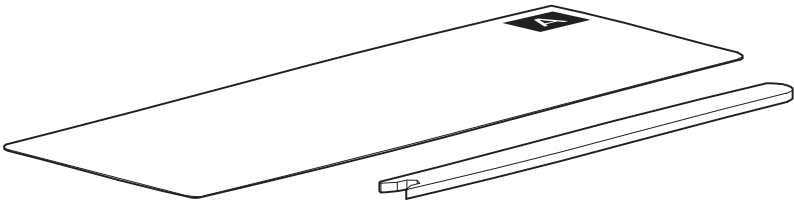

FJ.MT.AC.M+

FJ.MT.AS.M

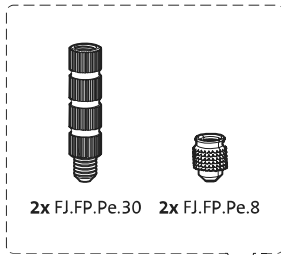

2x FJ.FP.Pe.30 2x FJ.FP.Pe.8

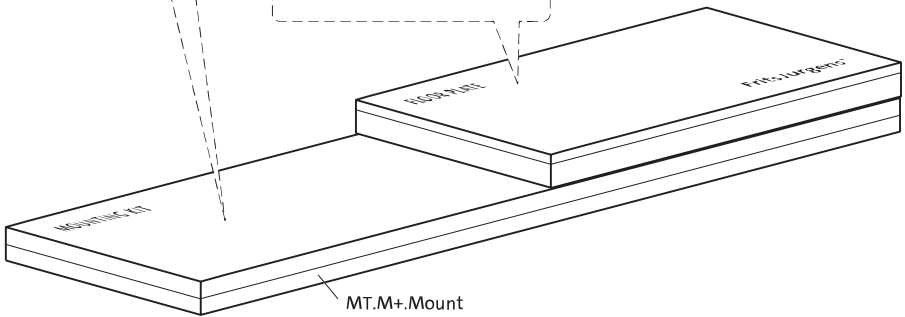

MT.M+.Mount

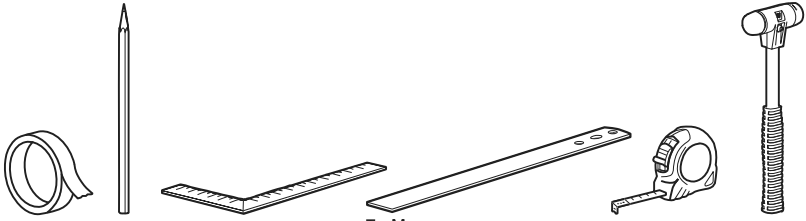

To.M

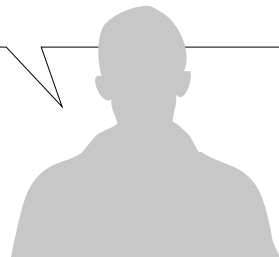
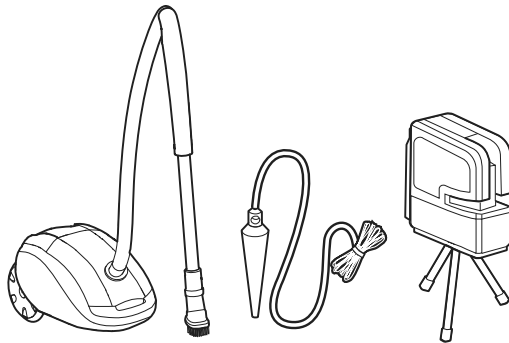
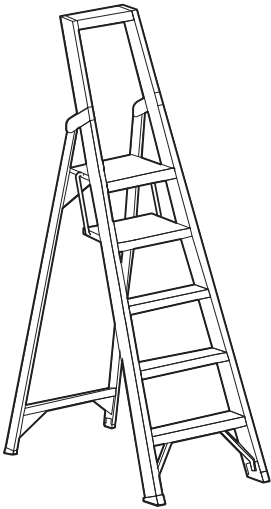
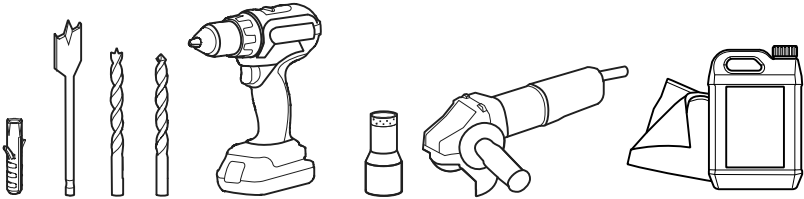

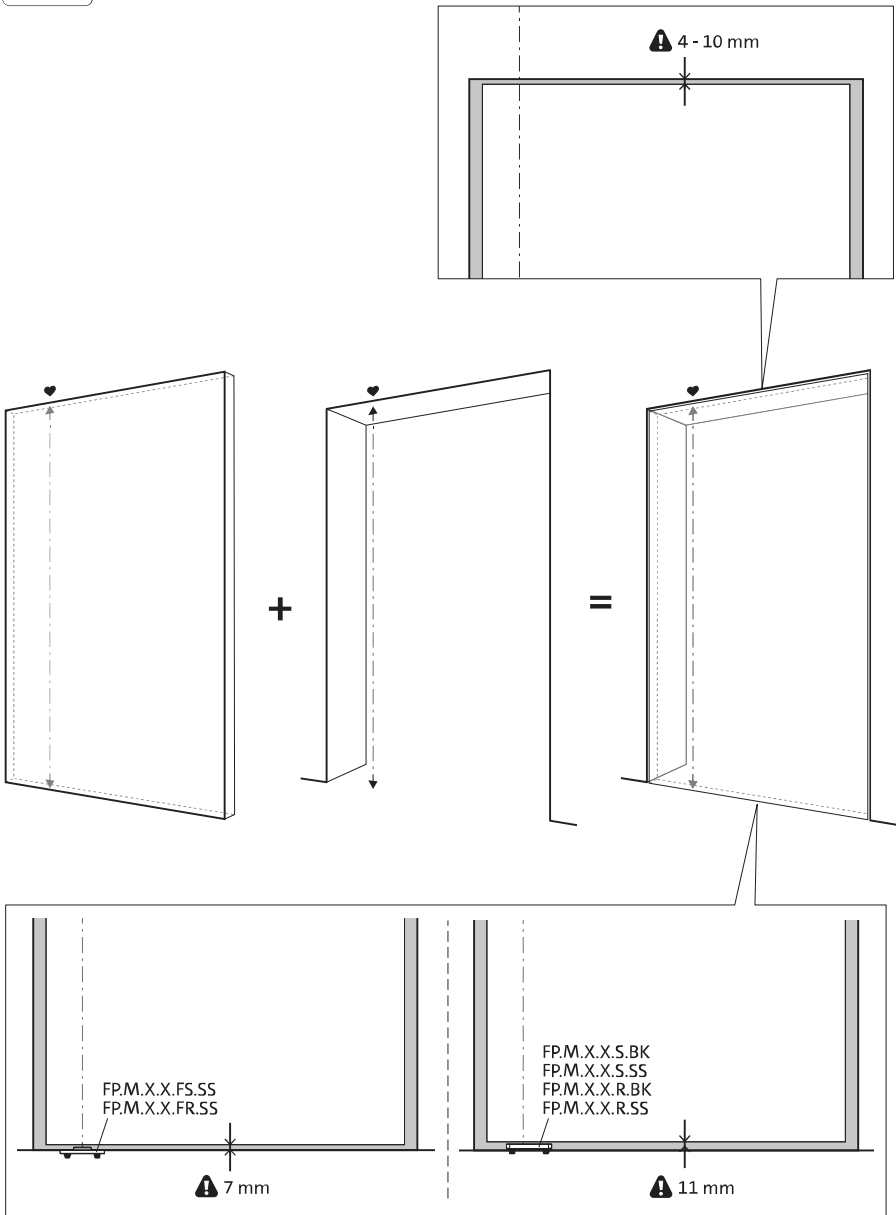

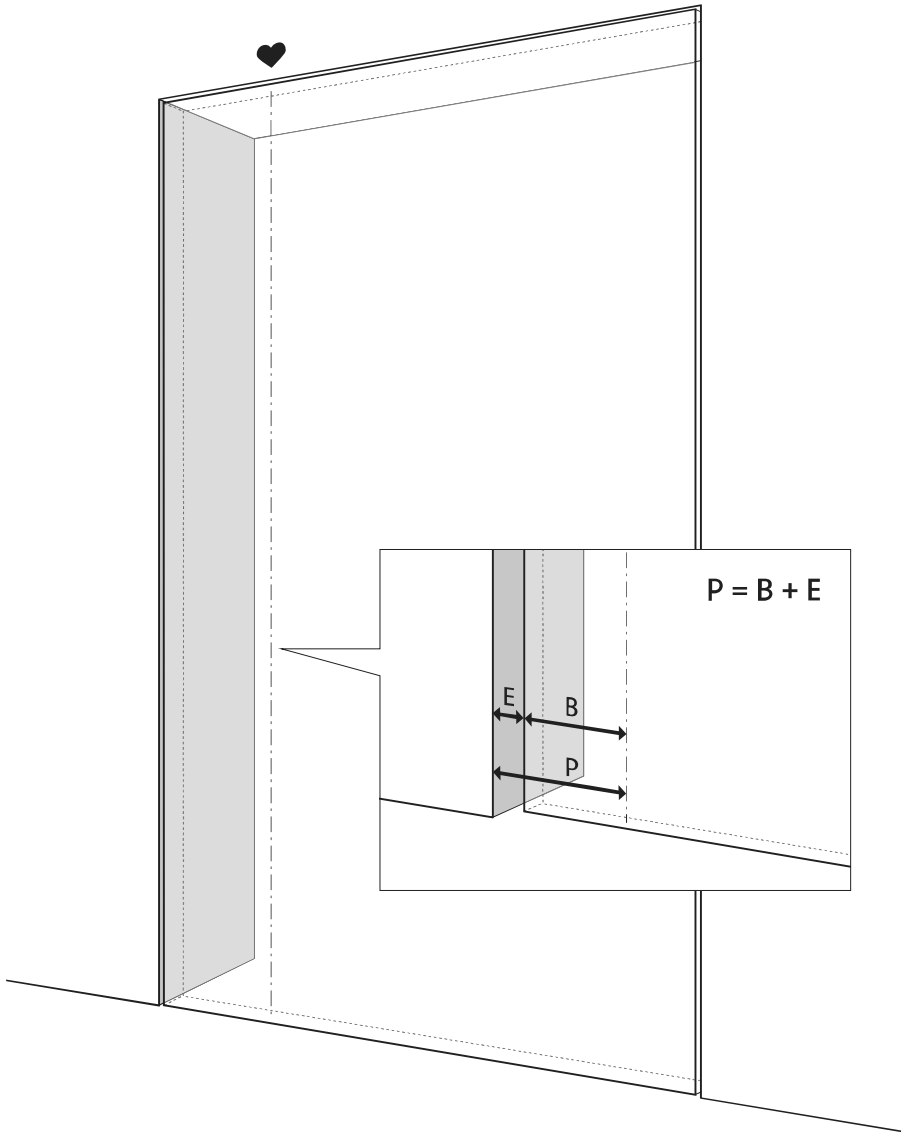

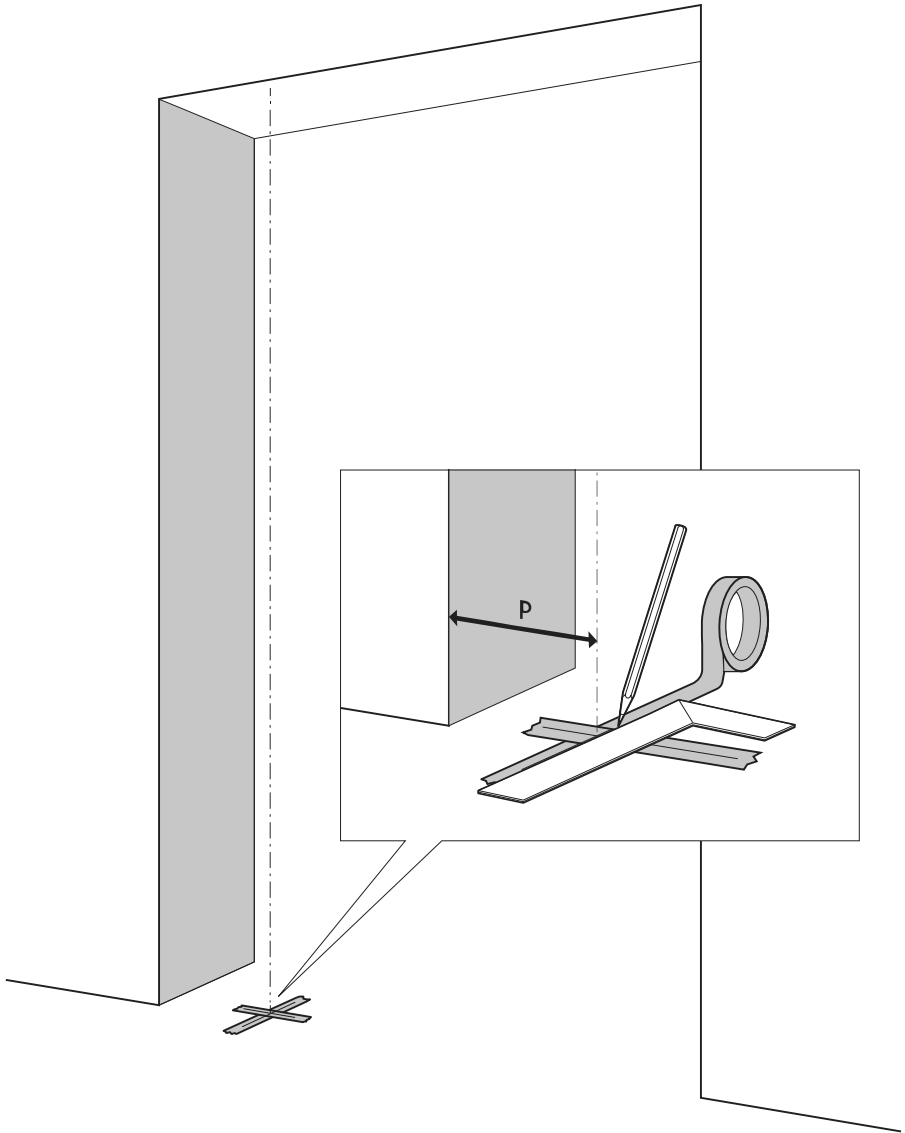



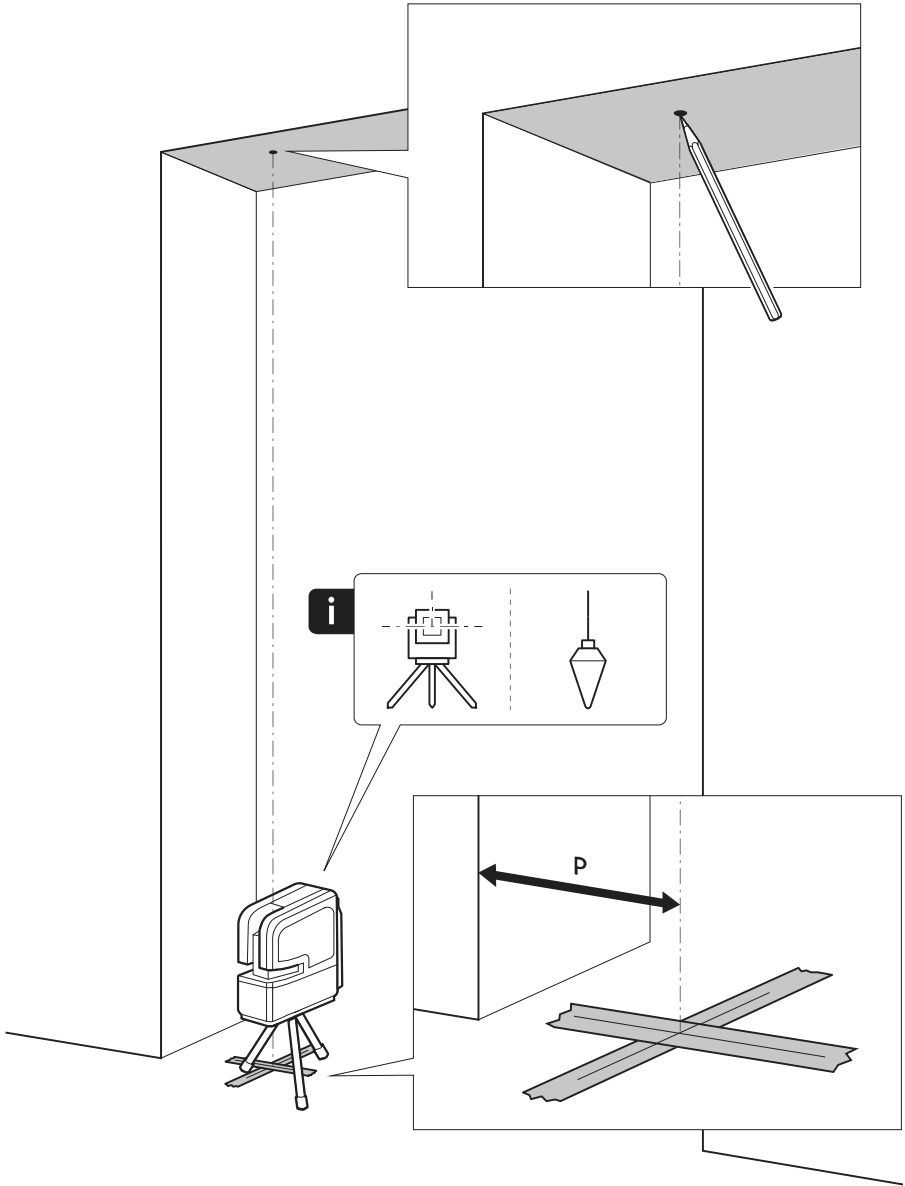
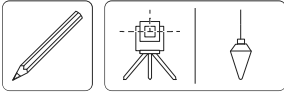

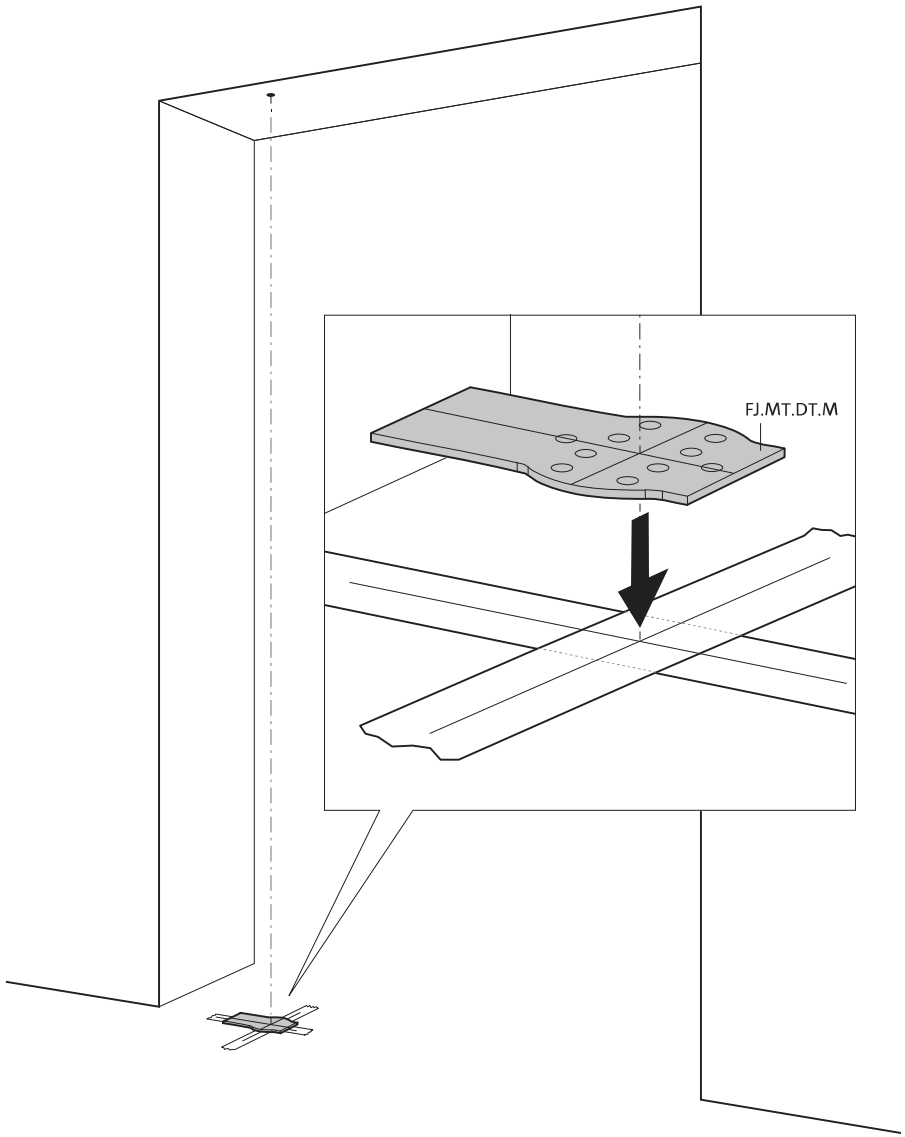

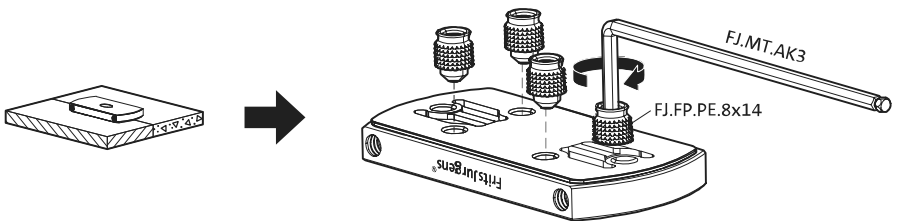
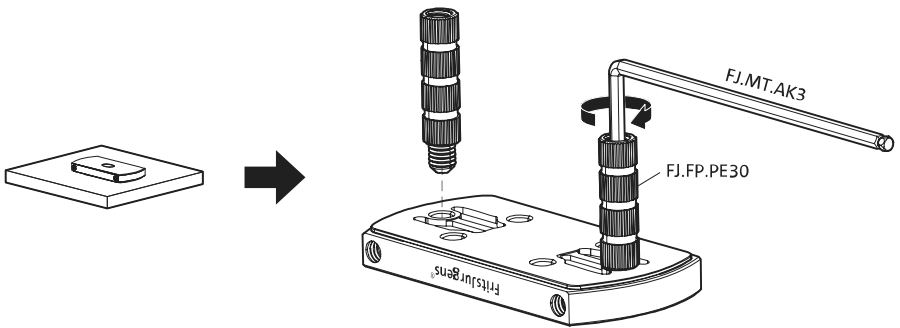
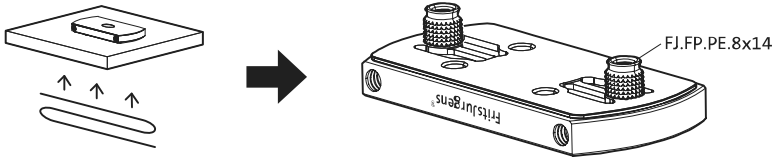

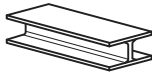

ø8 mm (5/16")

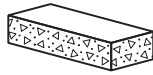
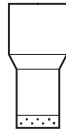

ø8 mm (5/16")

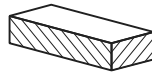

ø7.5 mm (19/64")

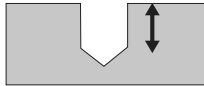

8 mm (5/16")

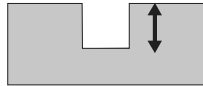

8 mm (5/16")

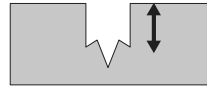

8 mm (5/16")

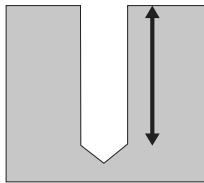
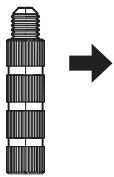

30 mm (13/16")

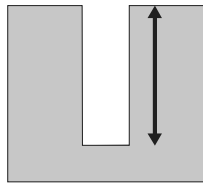

30 mm (13/16")

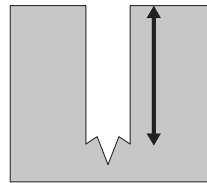

30 mm (13/16")

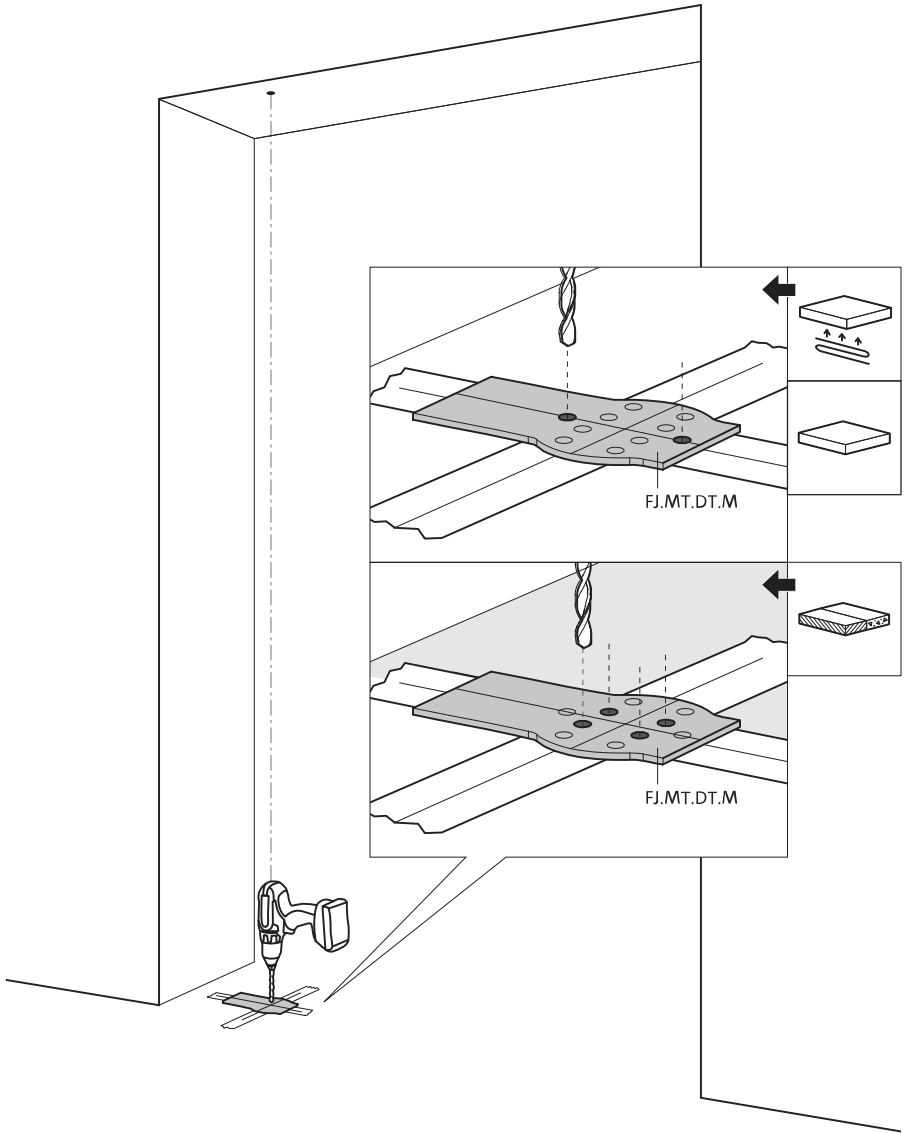

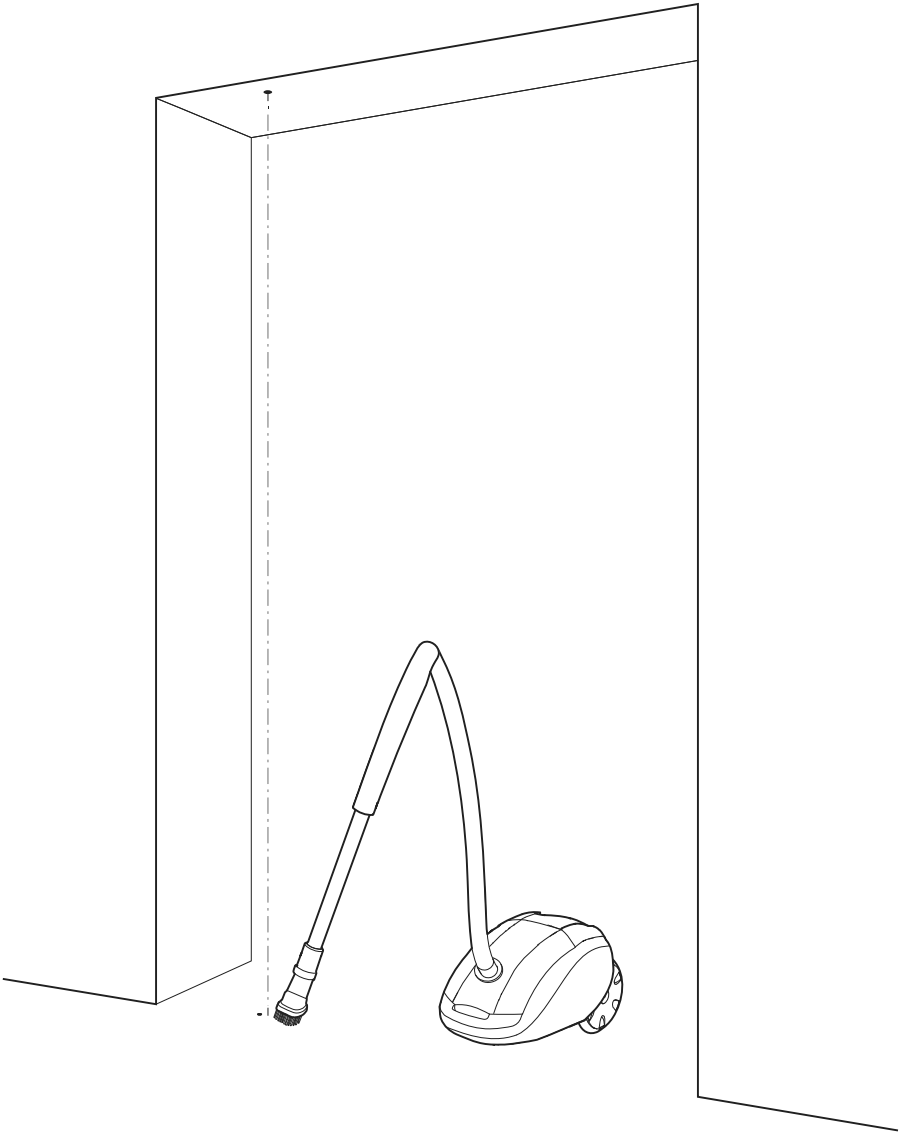



1

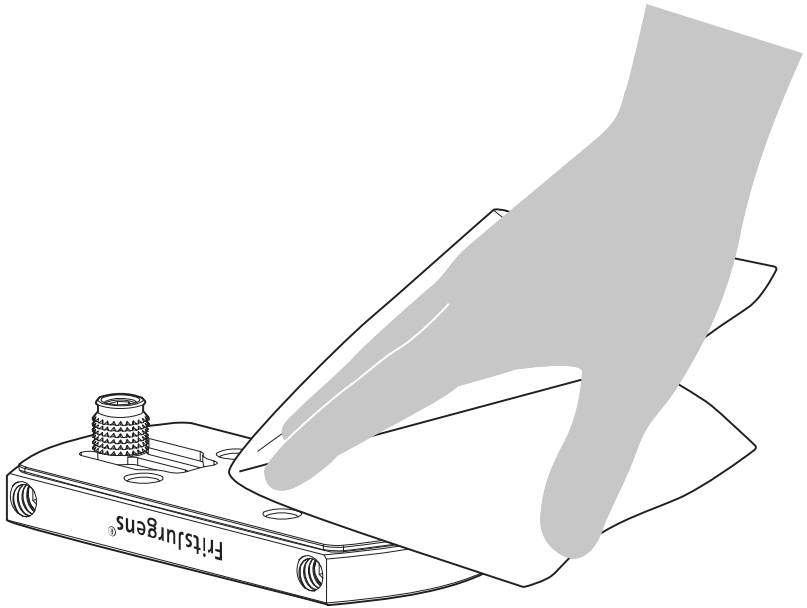

2

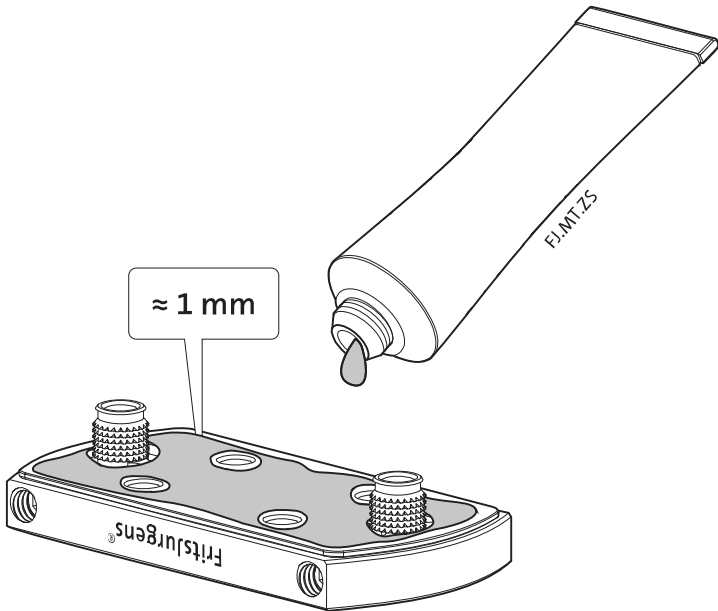

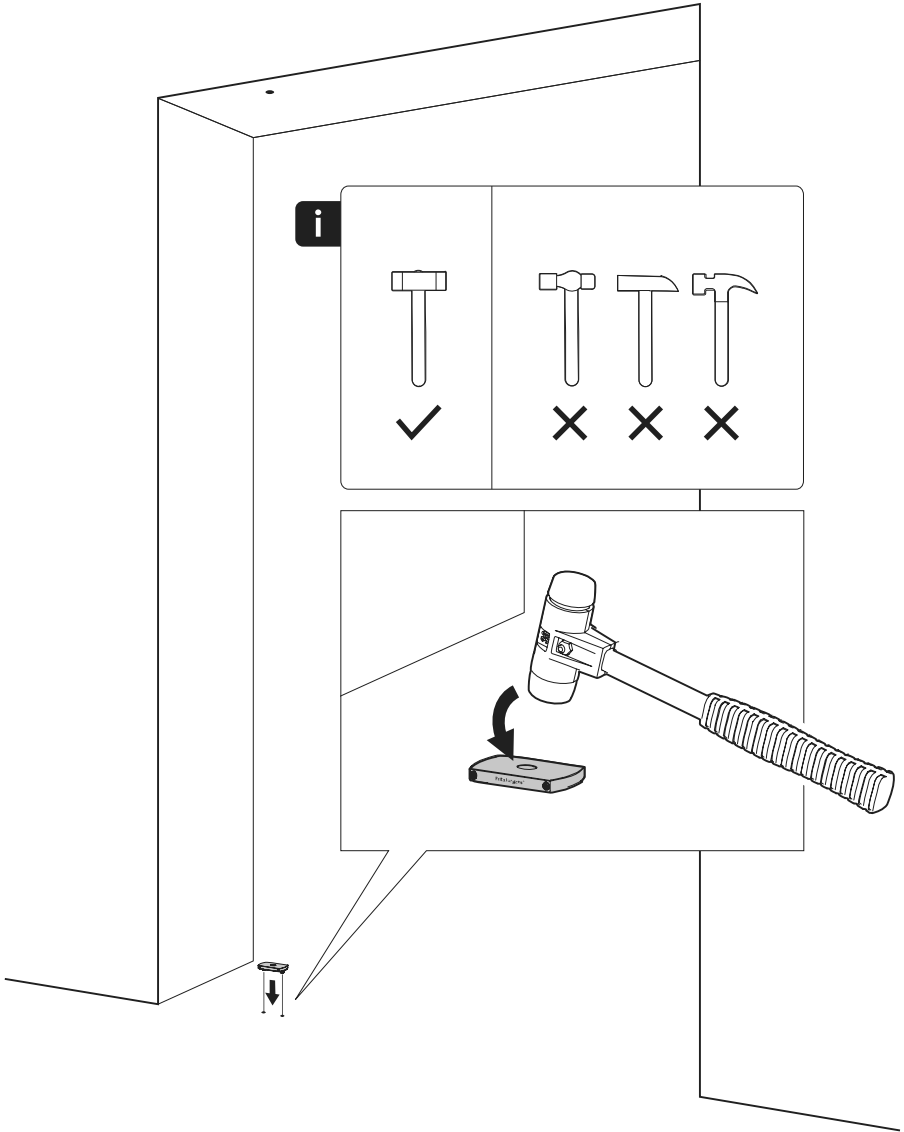



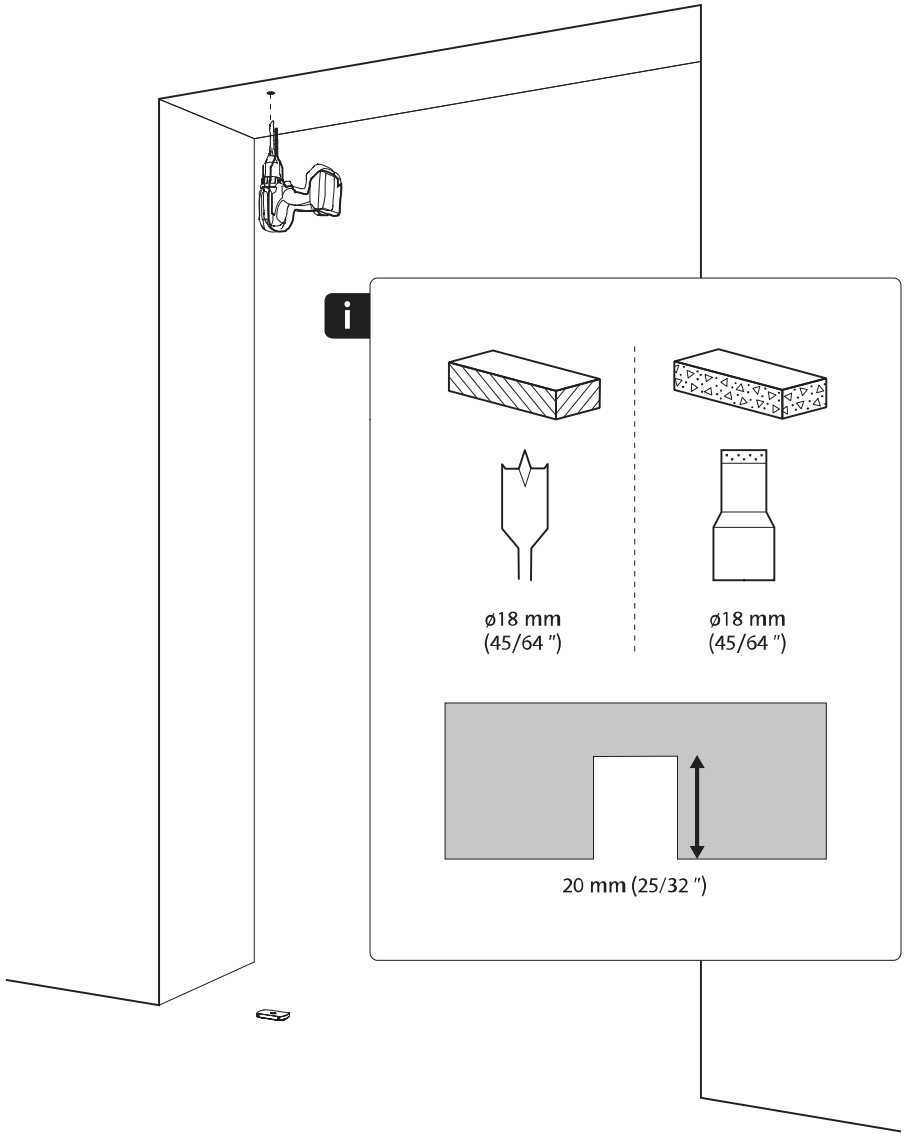
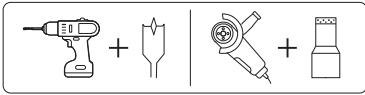



1

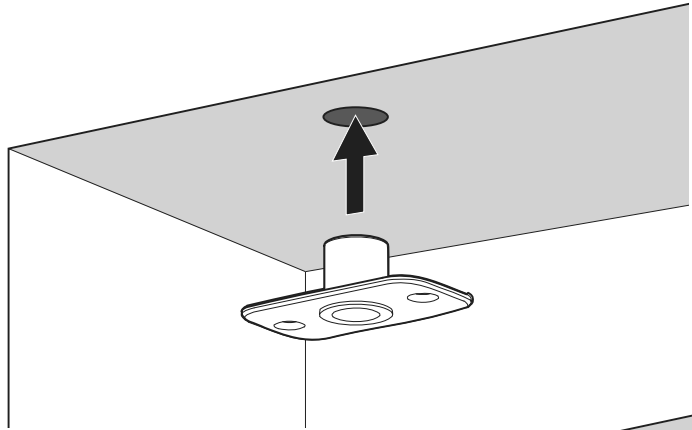

2

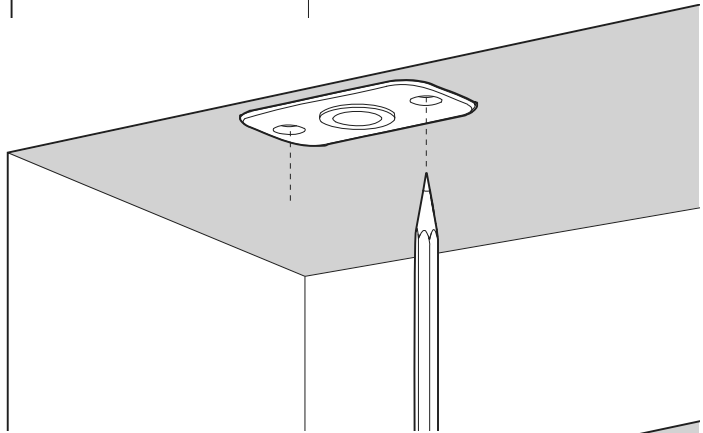

3

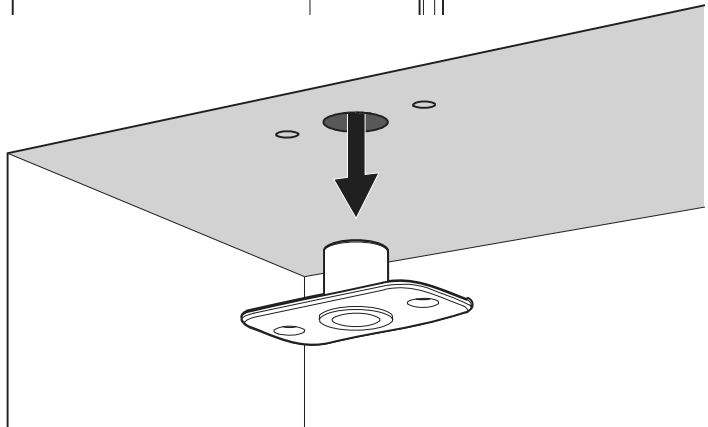



1

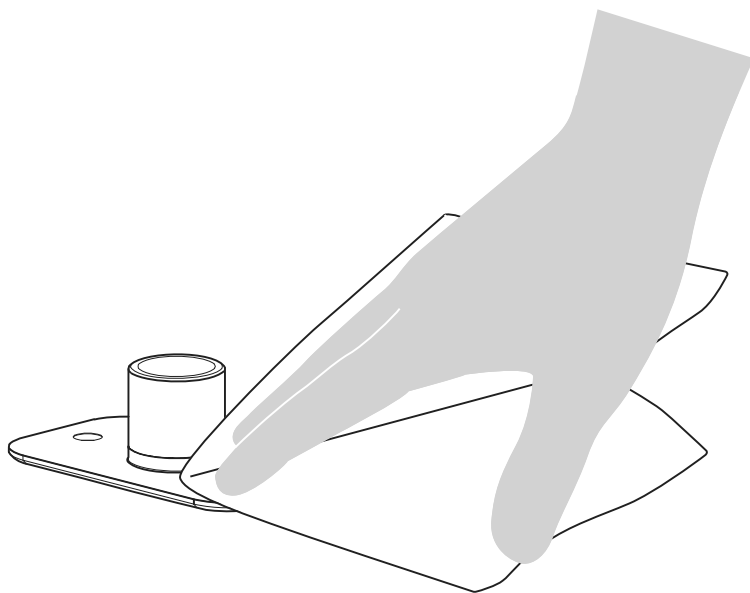

2

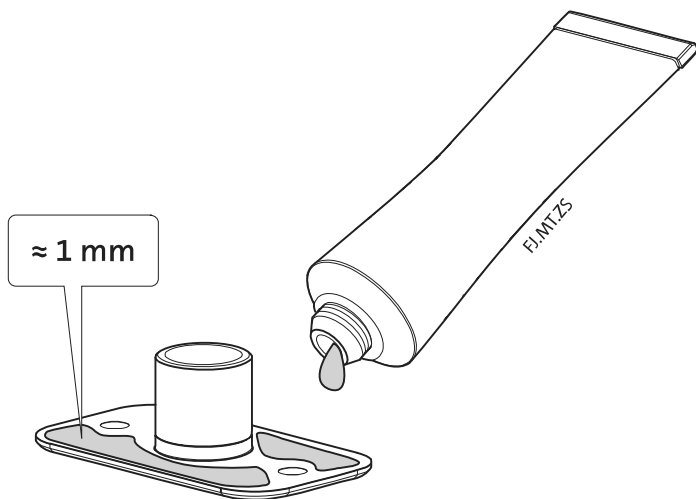

≈ 1 mm

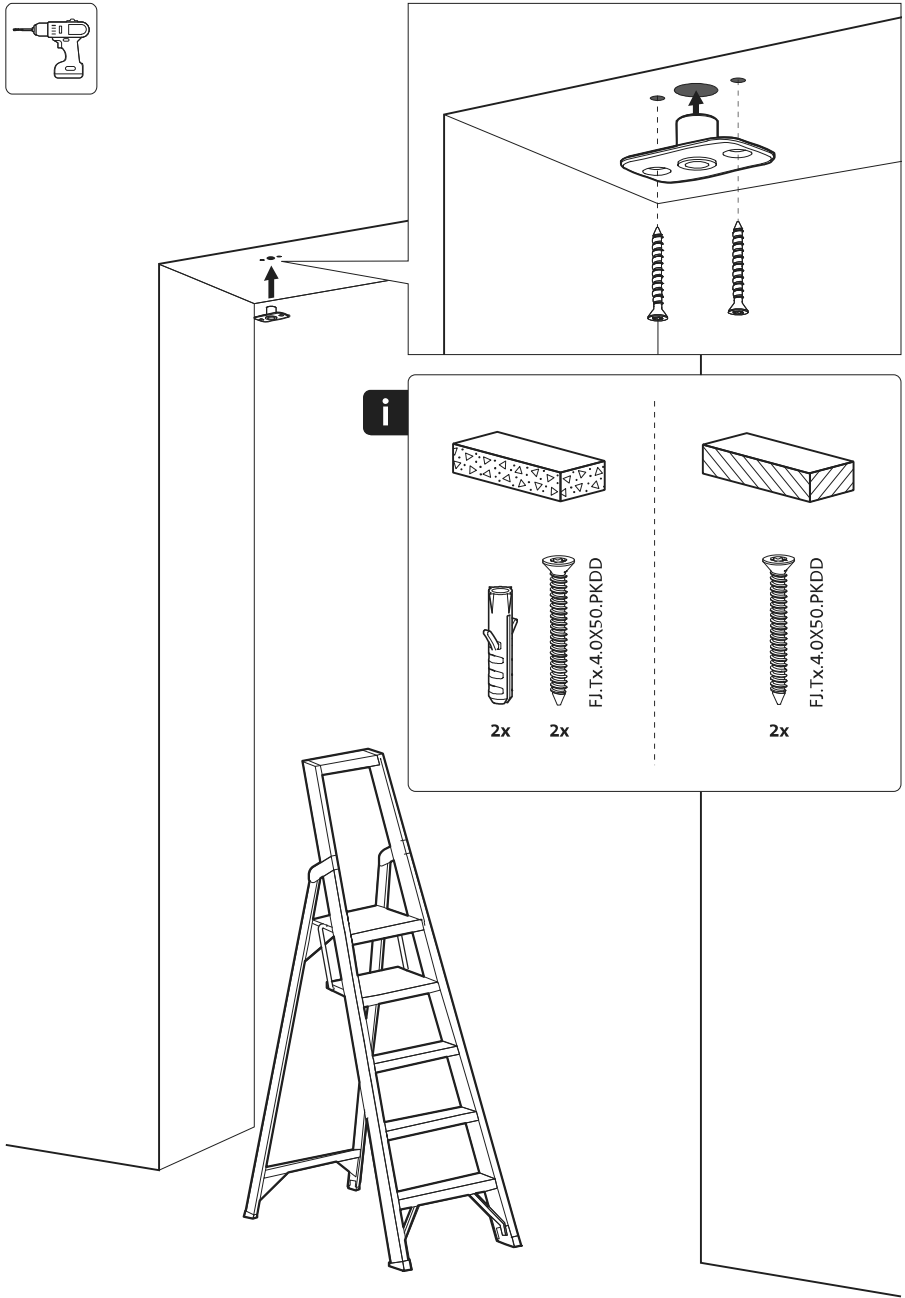

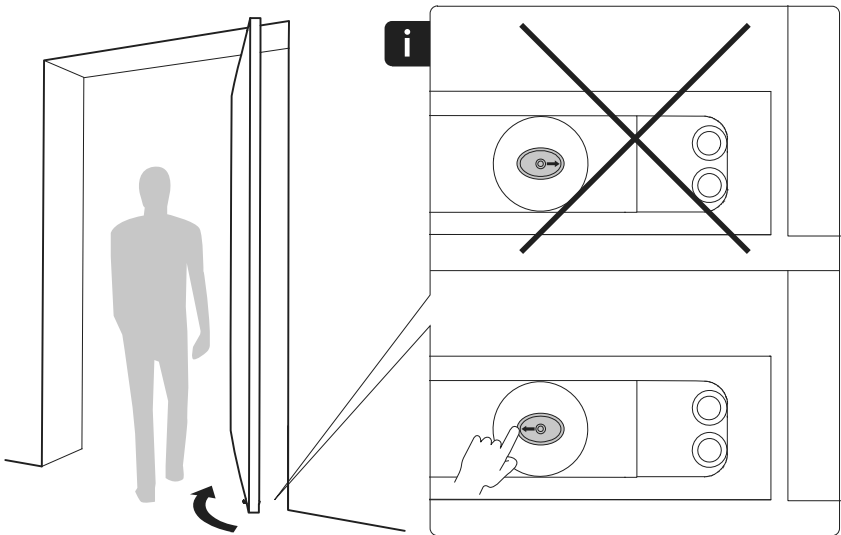
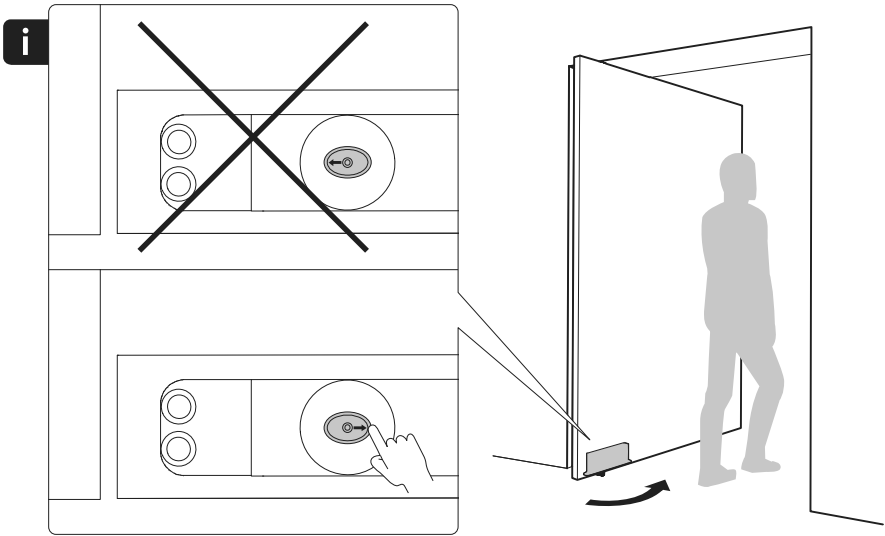

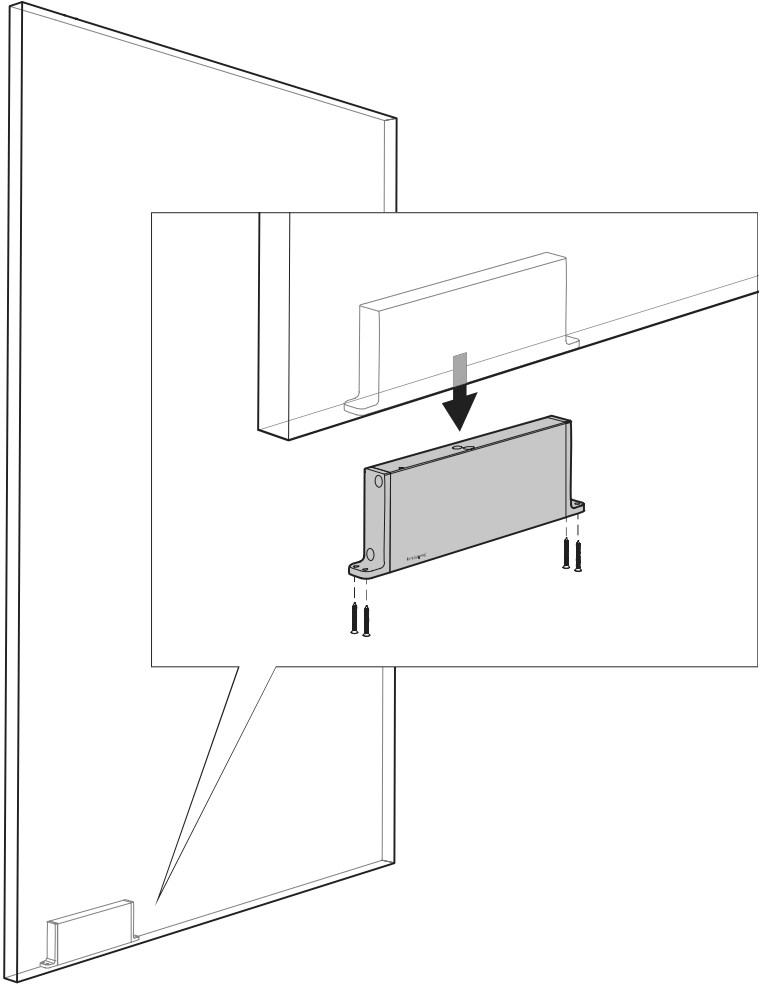

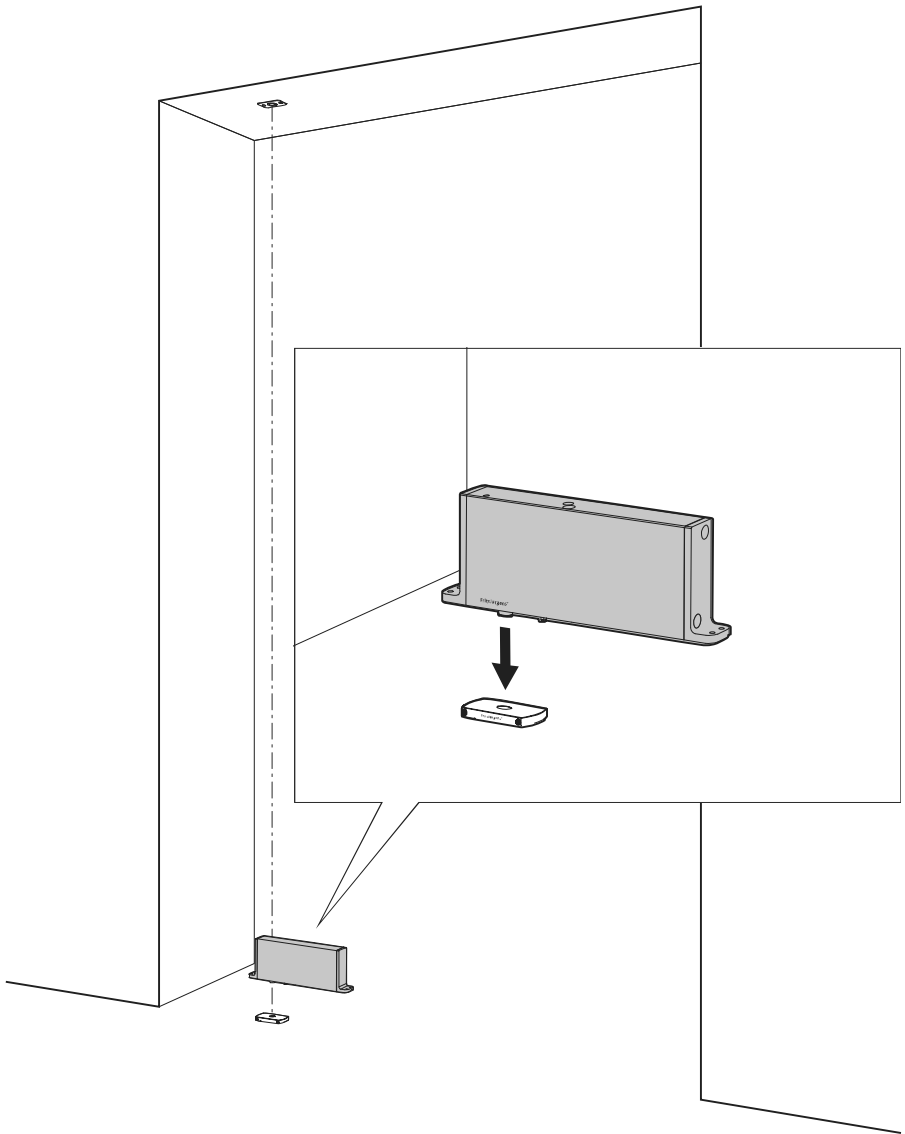

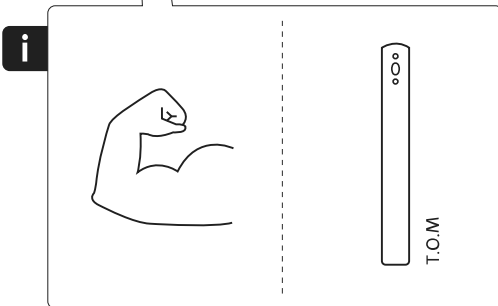
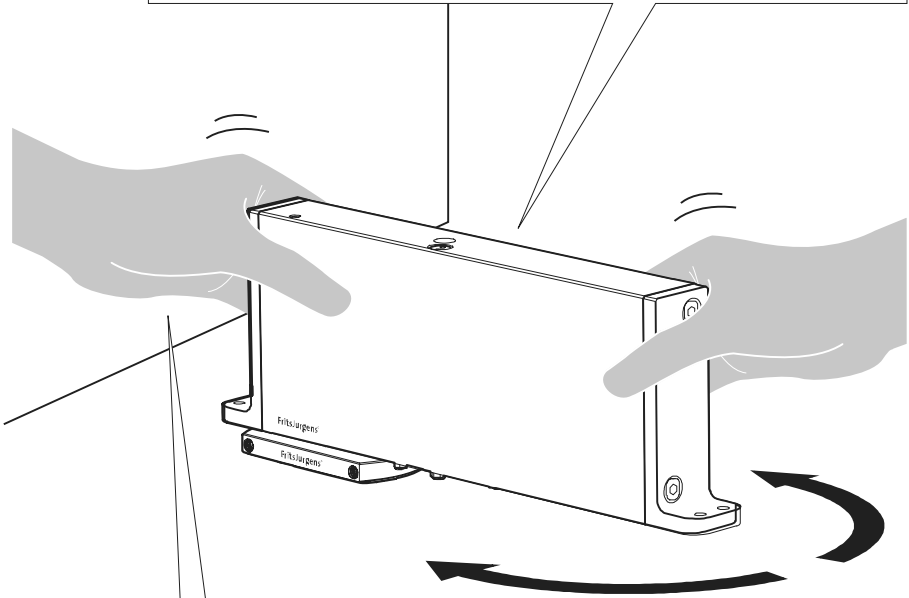
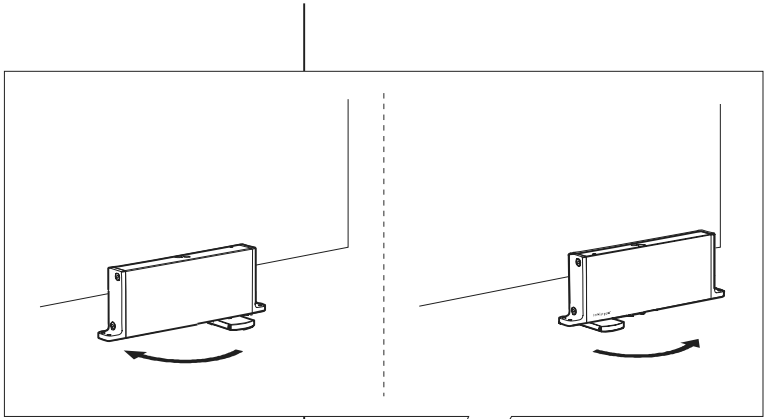



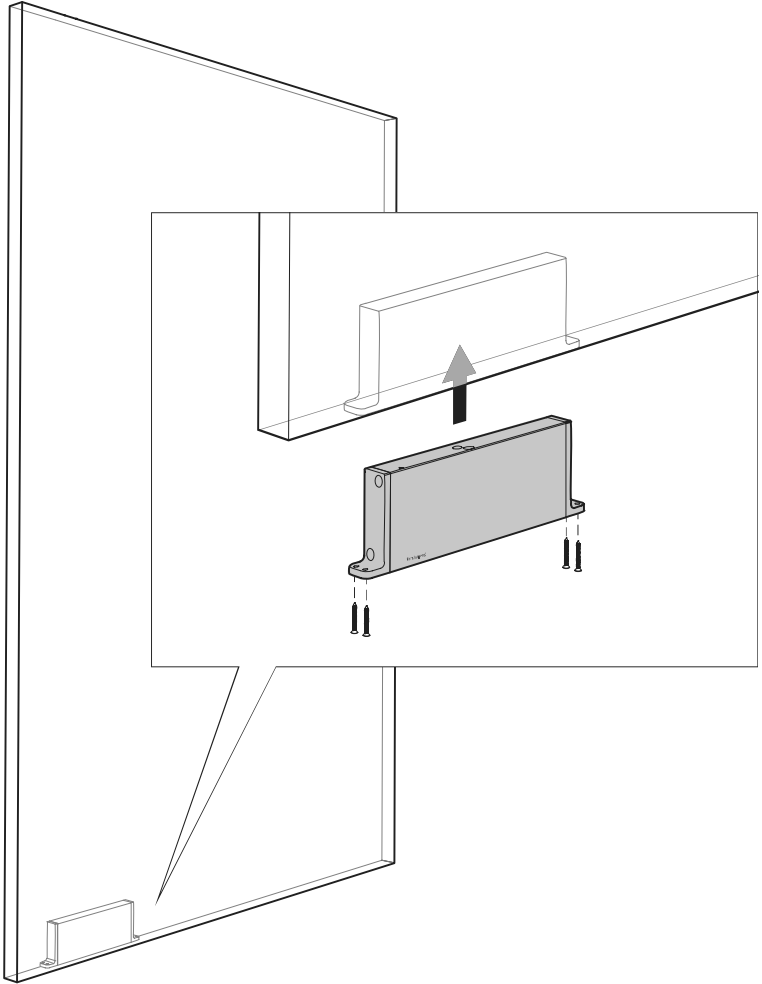

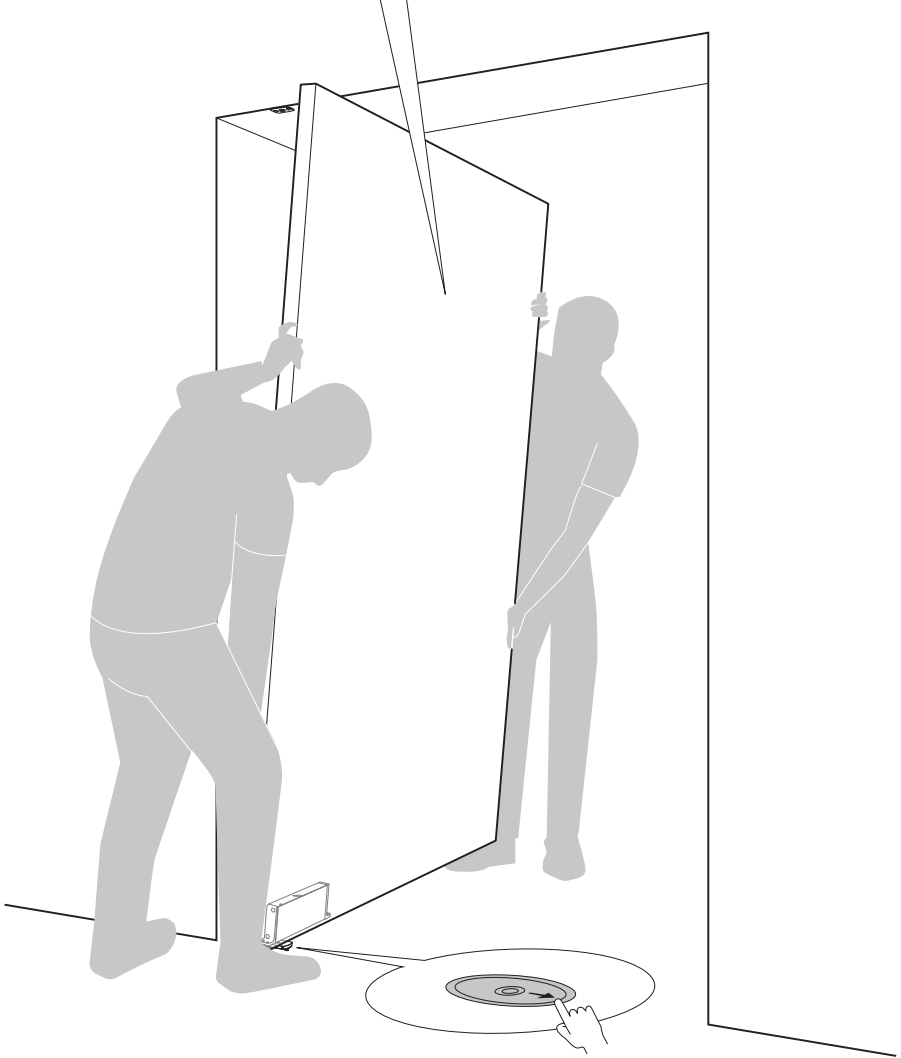
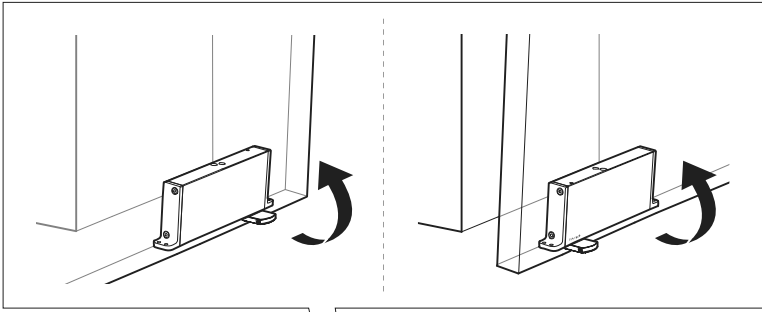

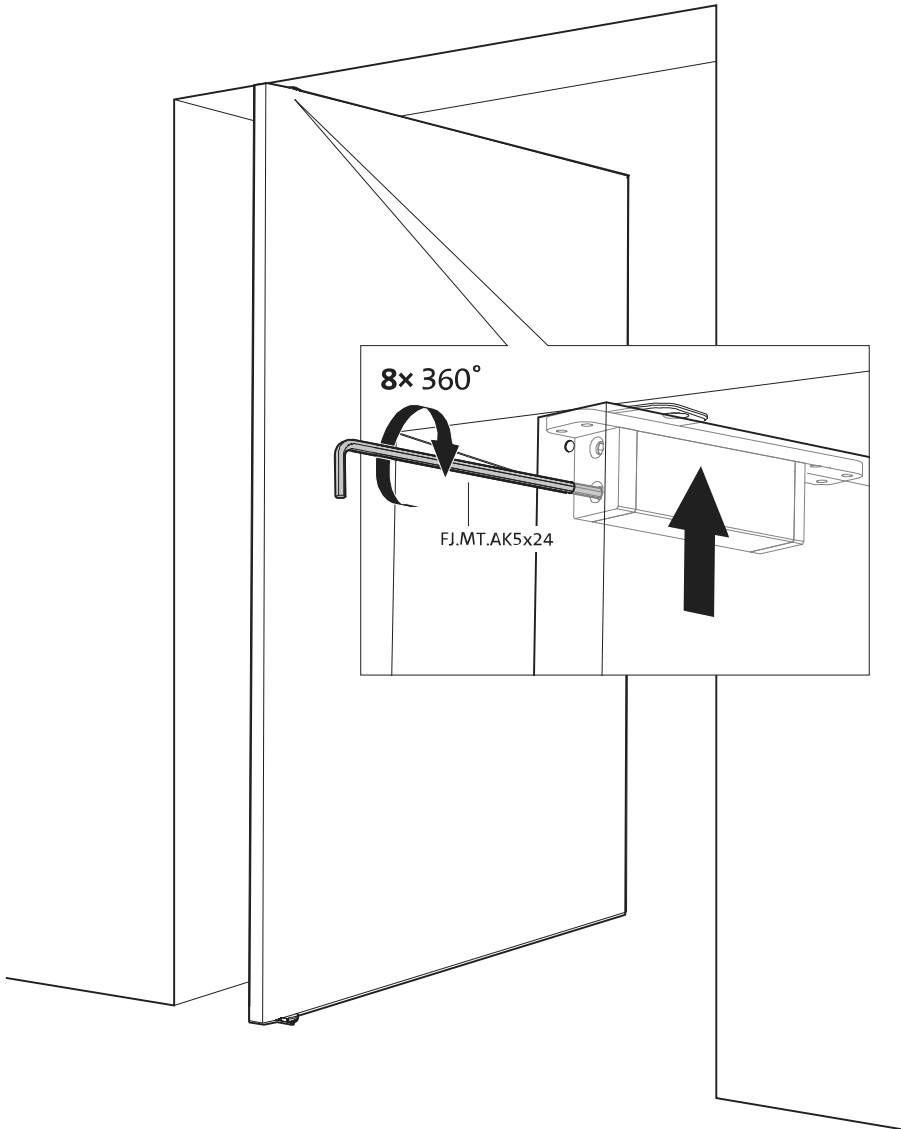
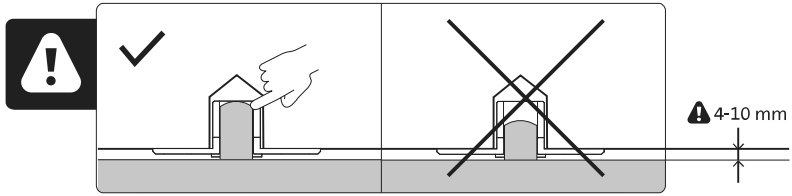

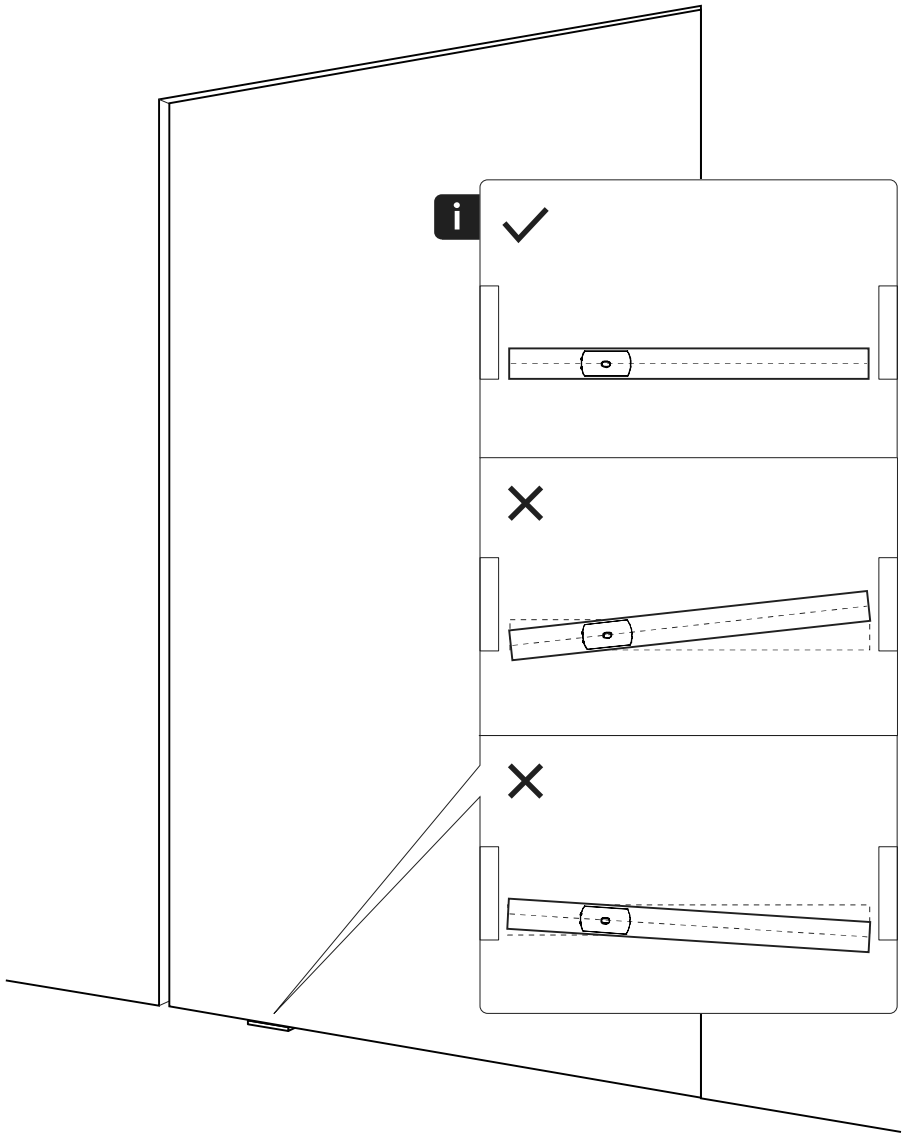

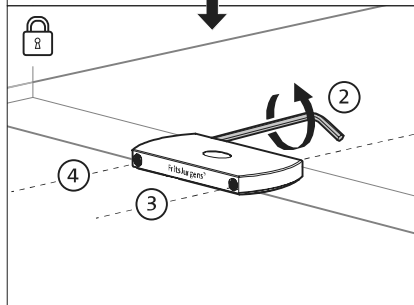
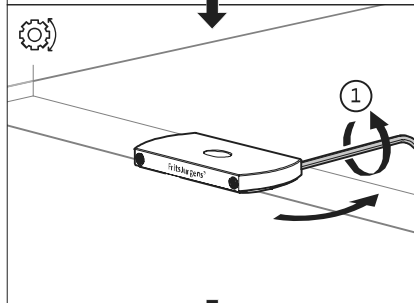
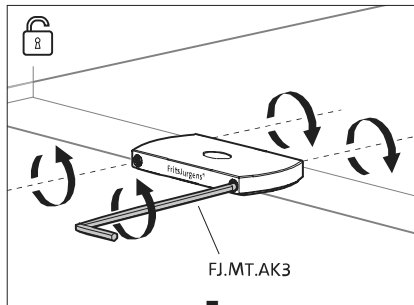
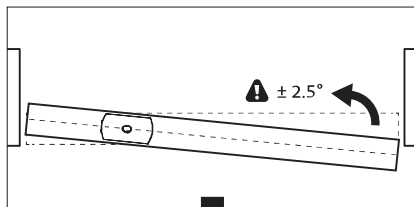
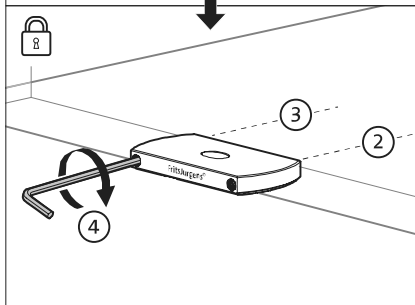
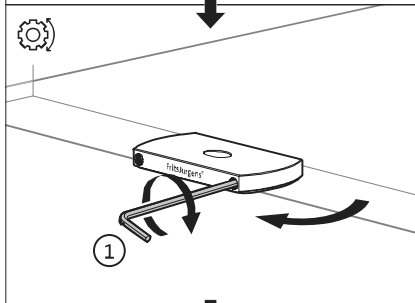
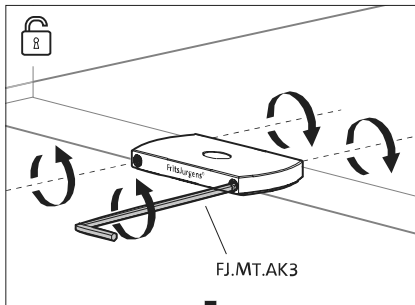
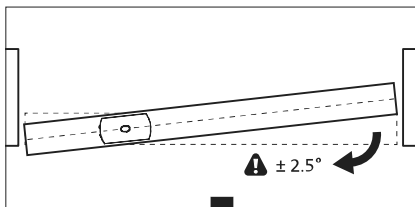

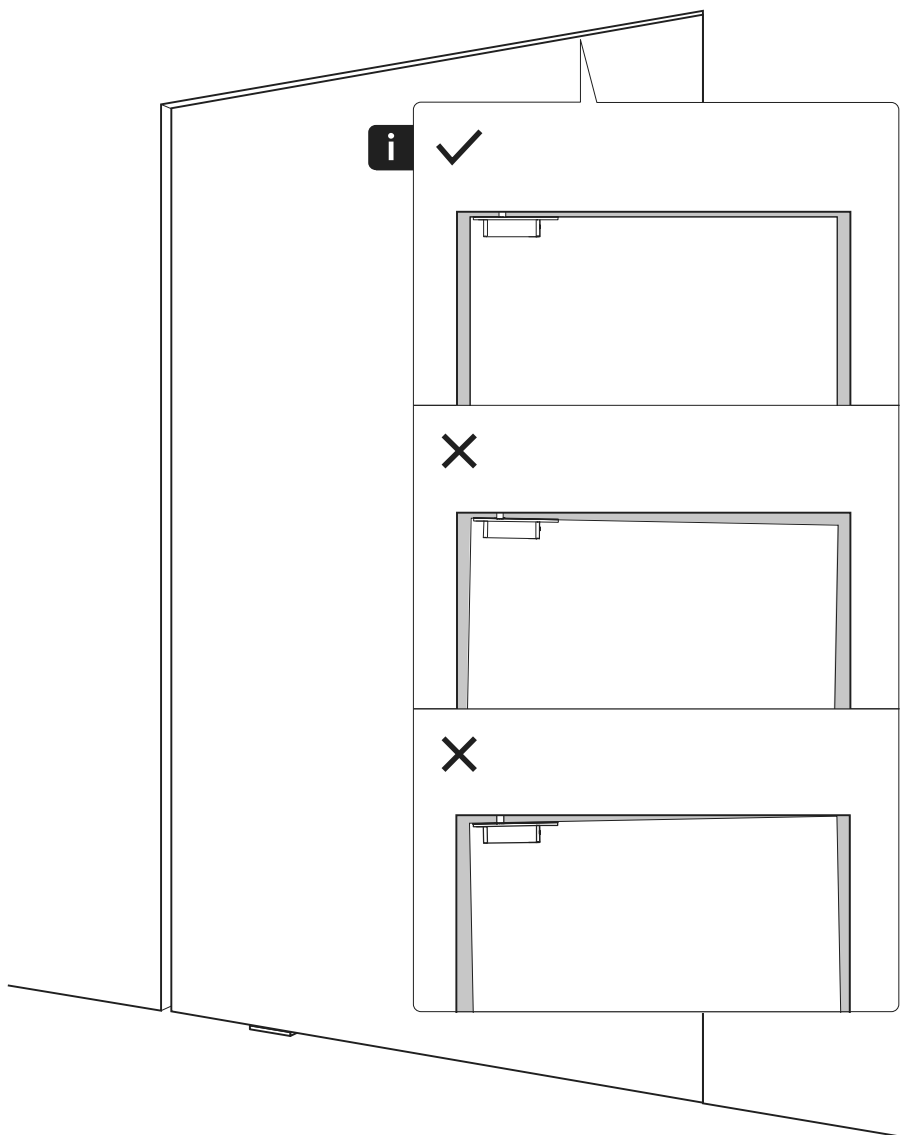

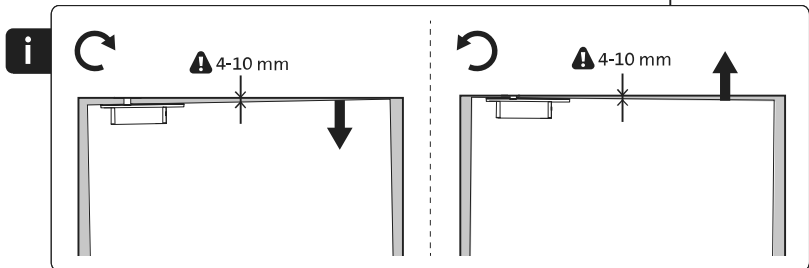
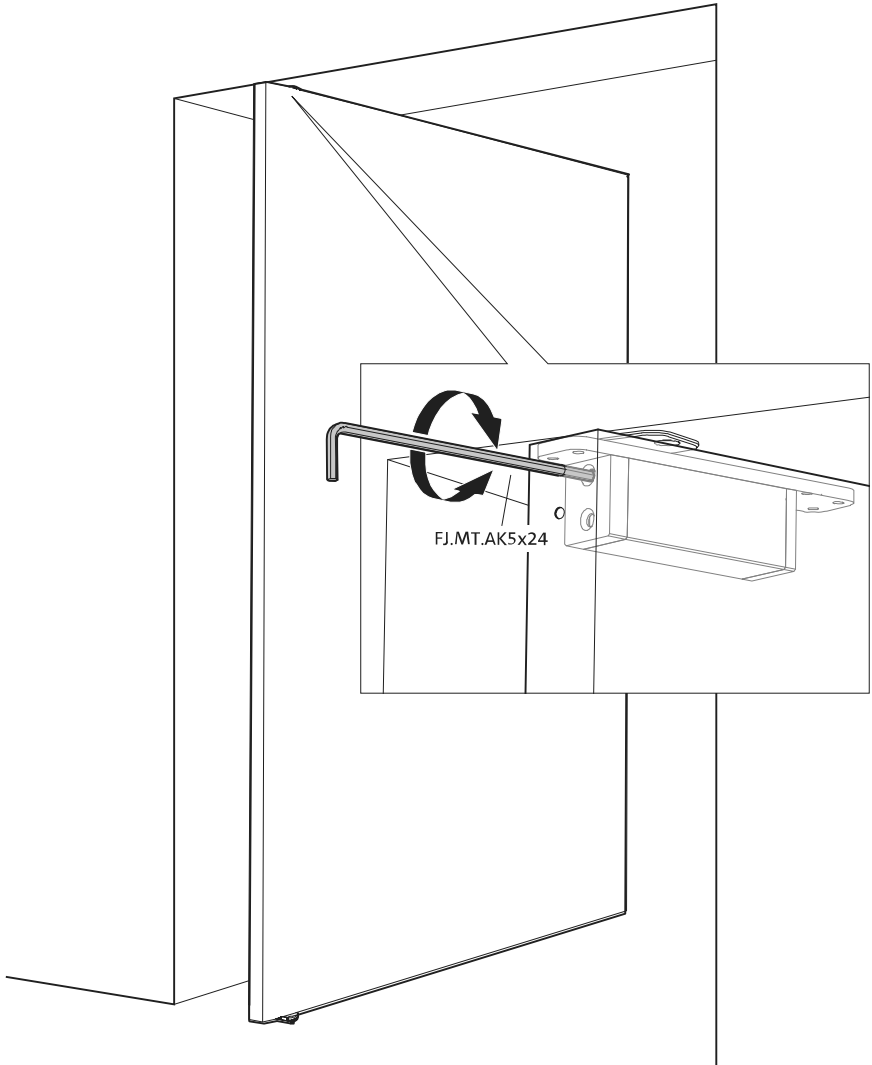

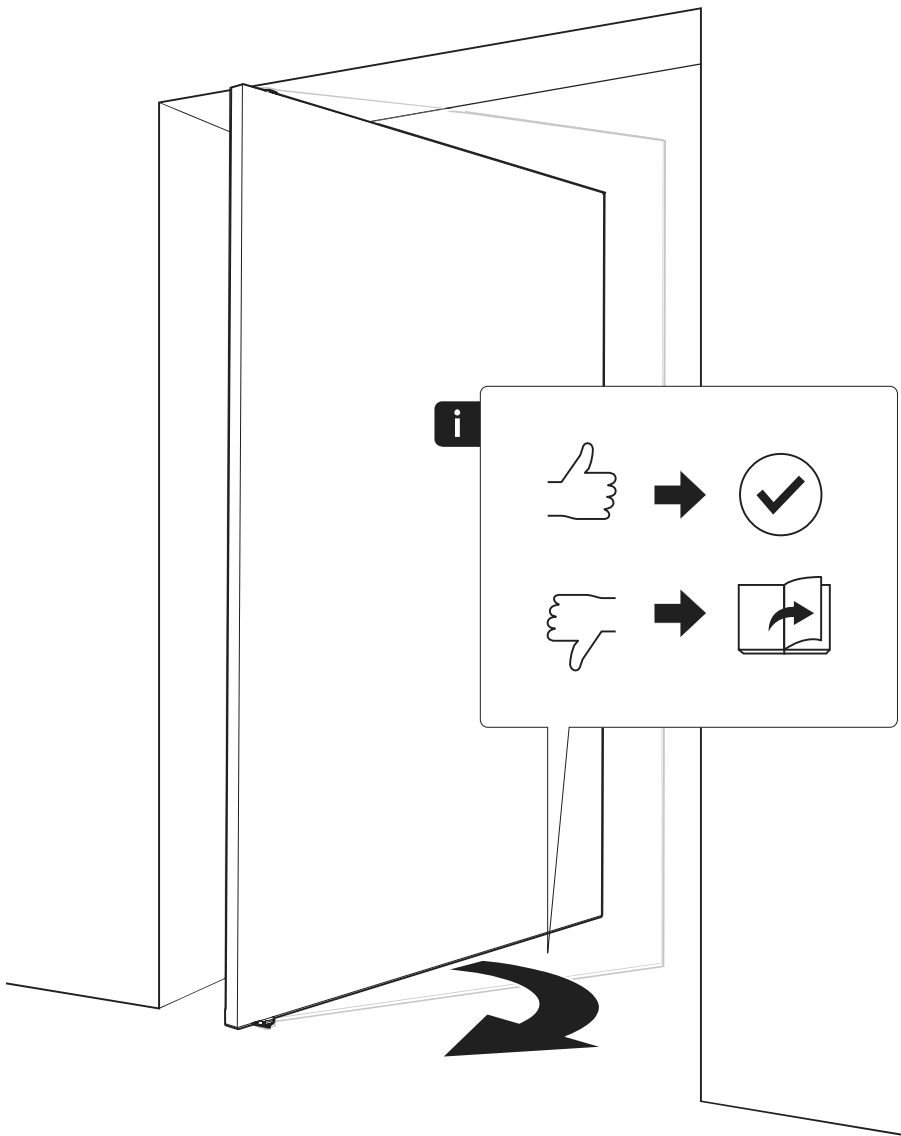





FJ.MT.AC.M+

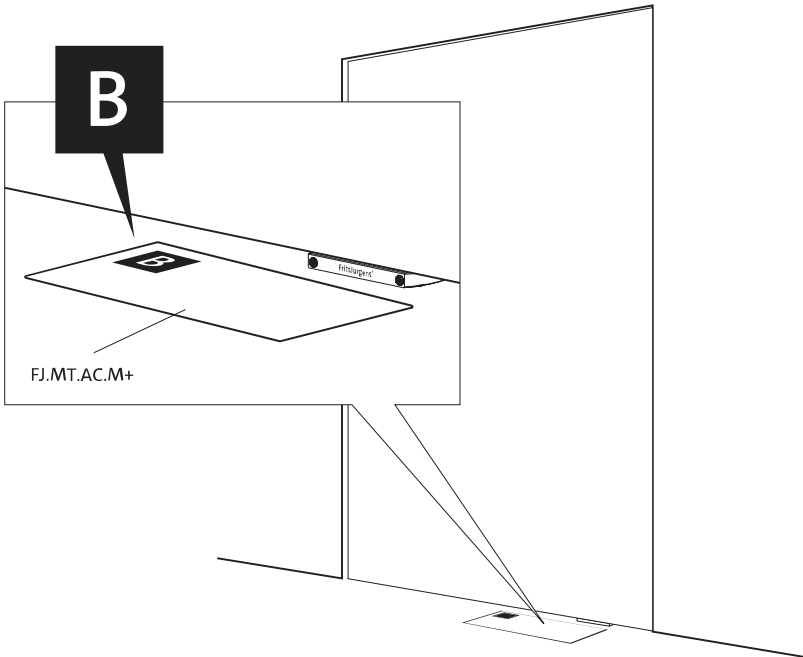
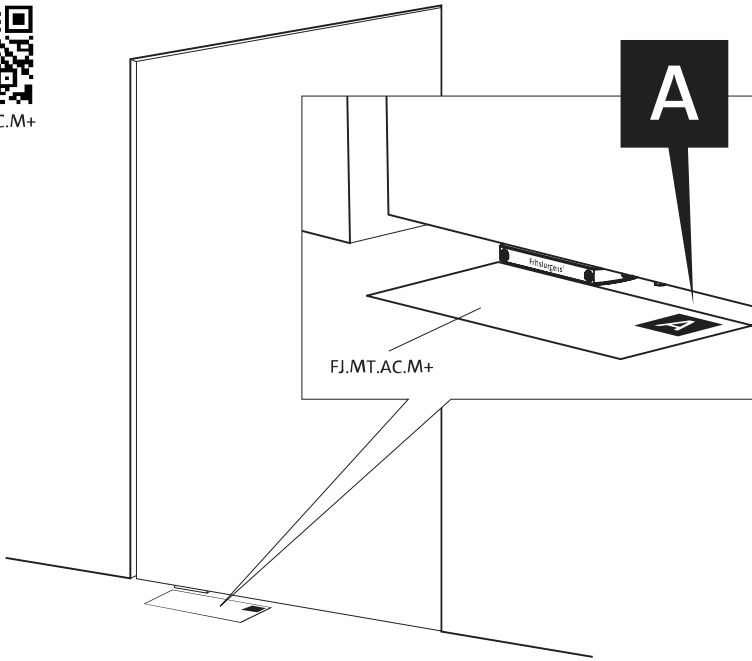

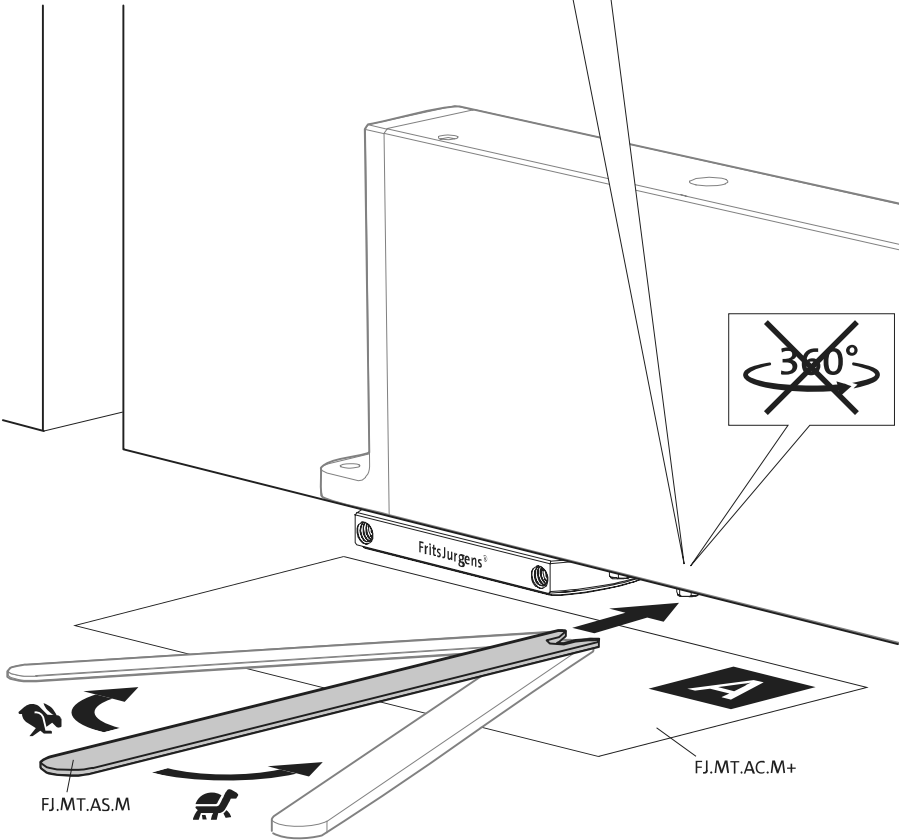
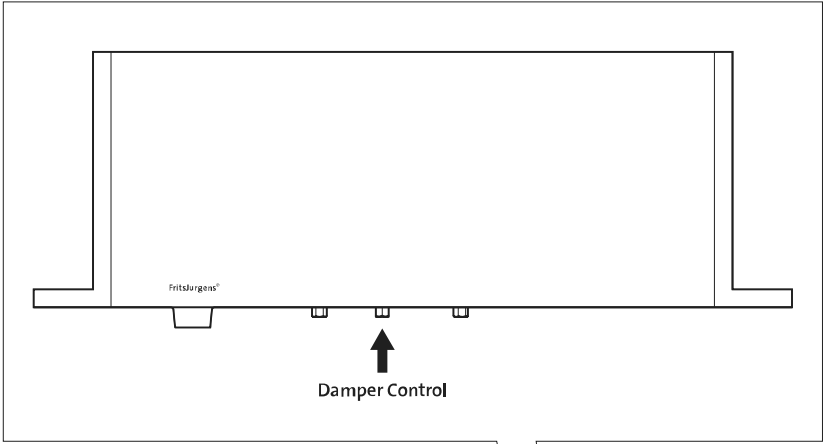

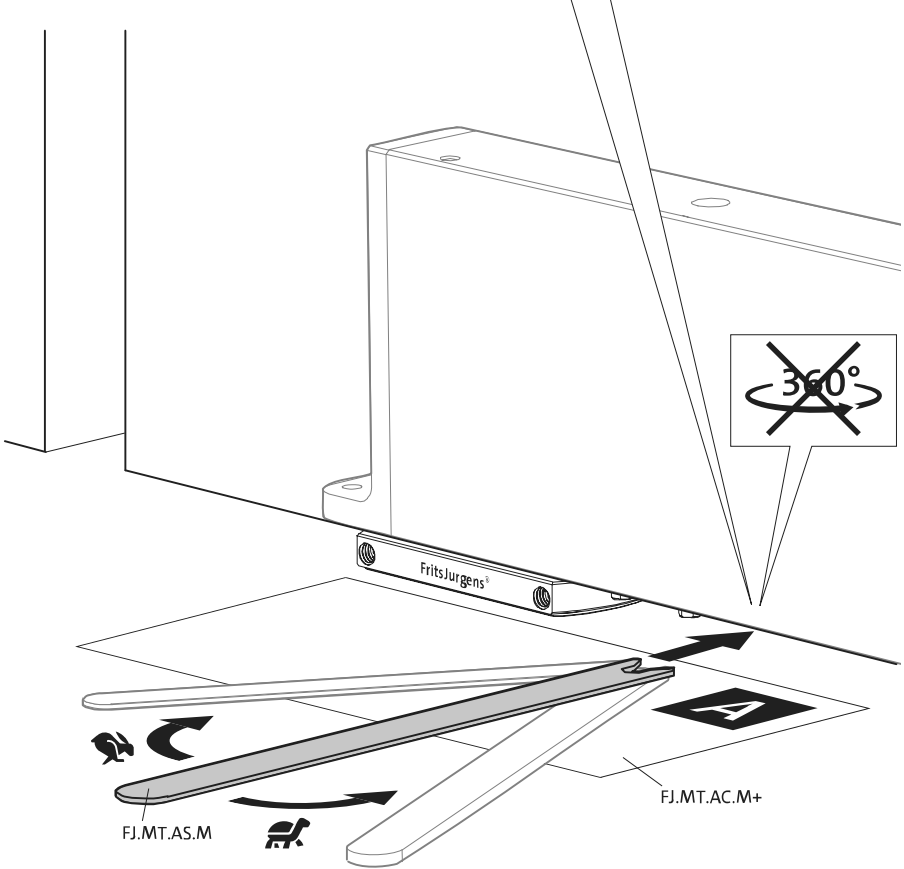
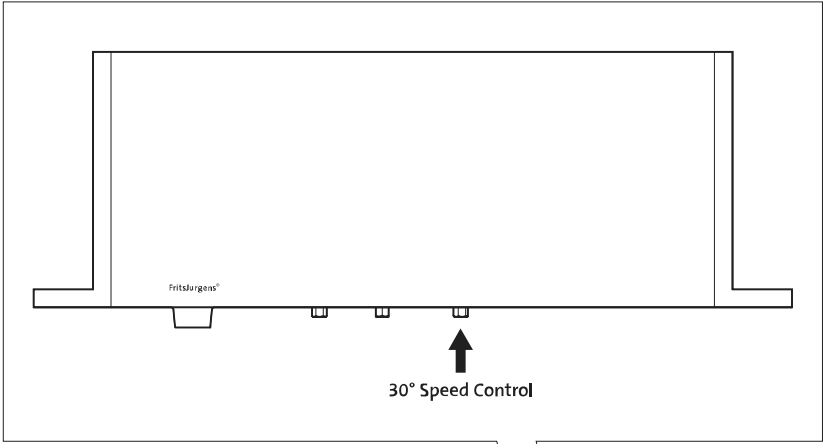

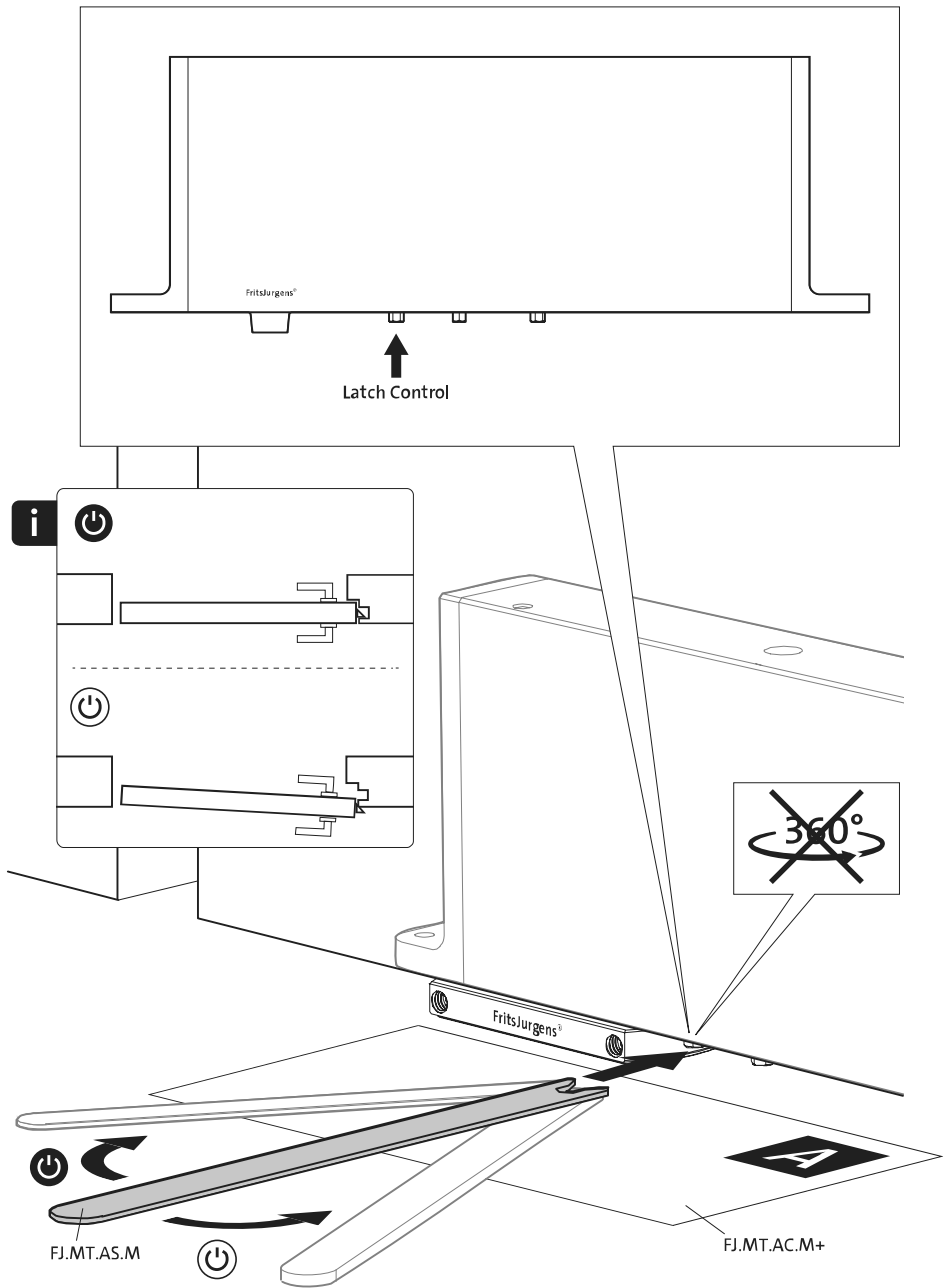

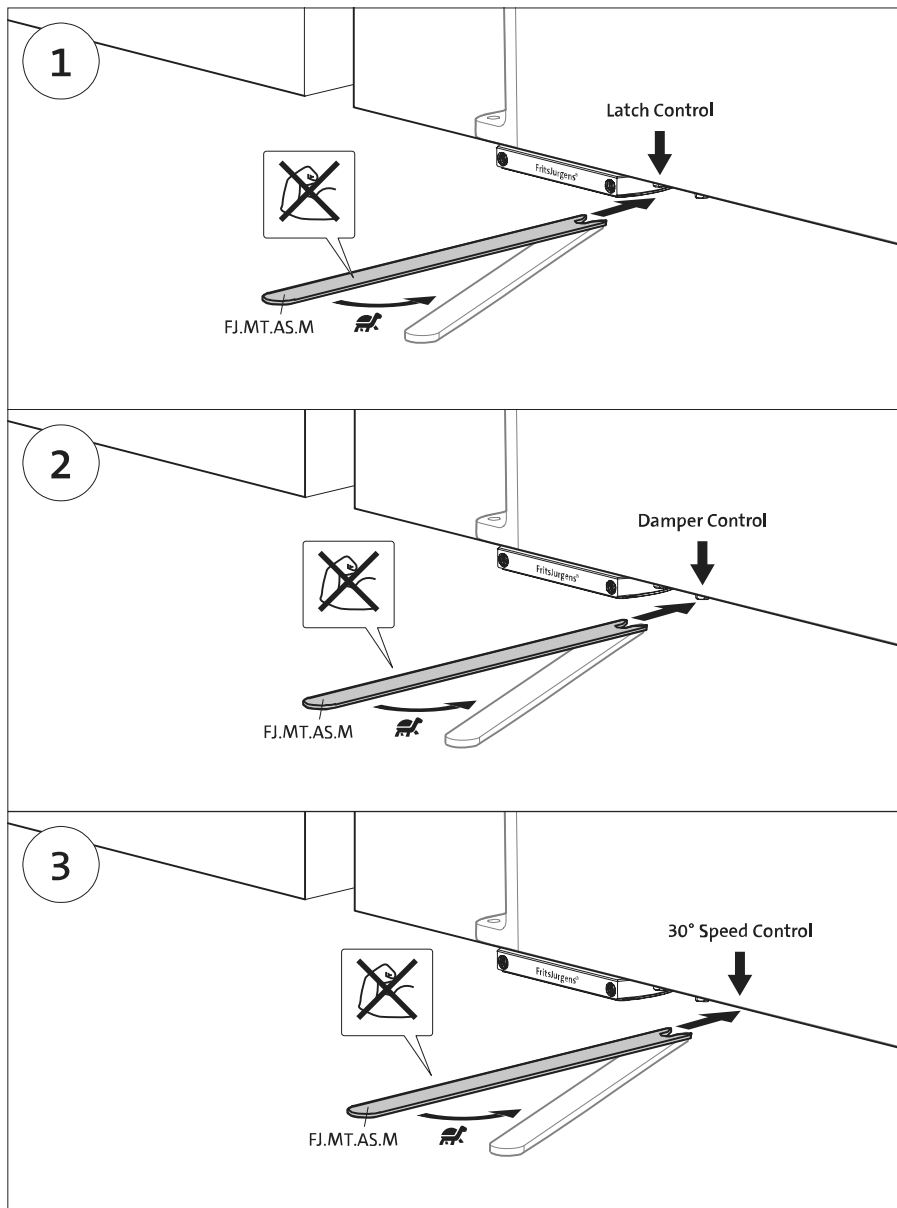

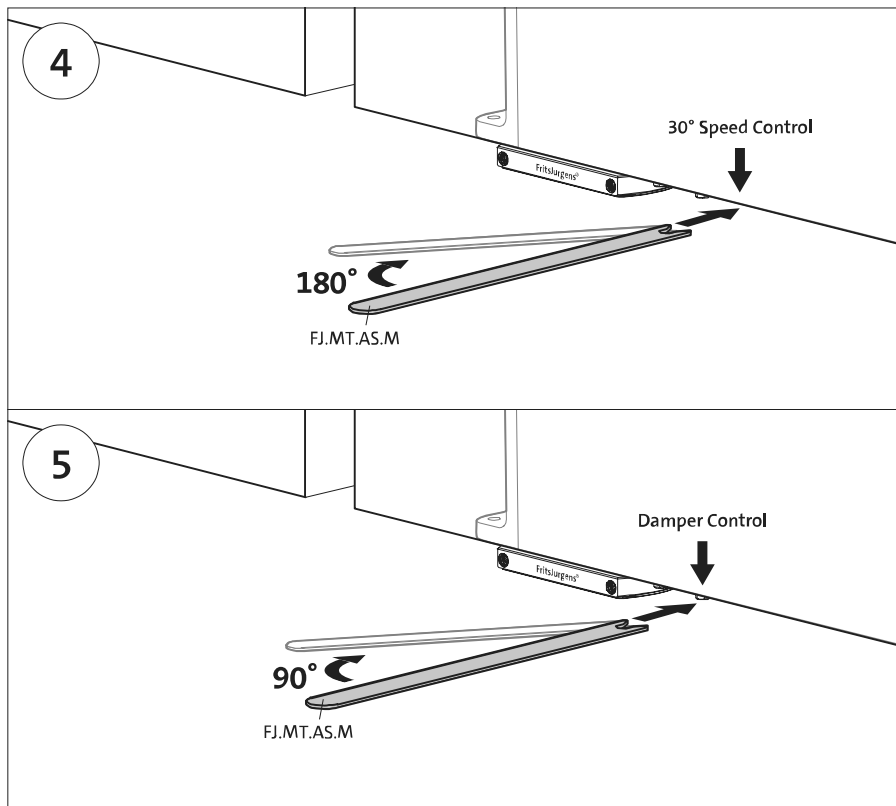

# Istruzioni di smontaggio

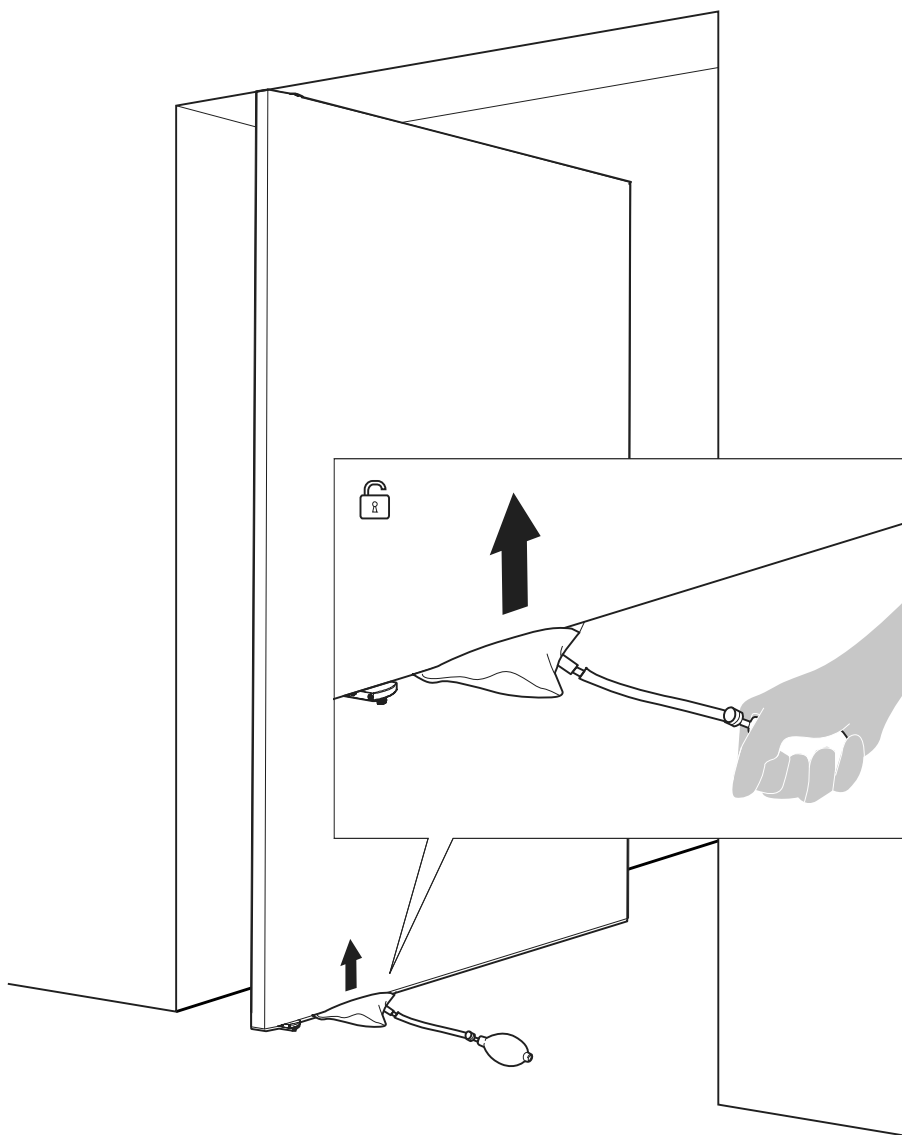



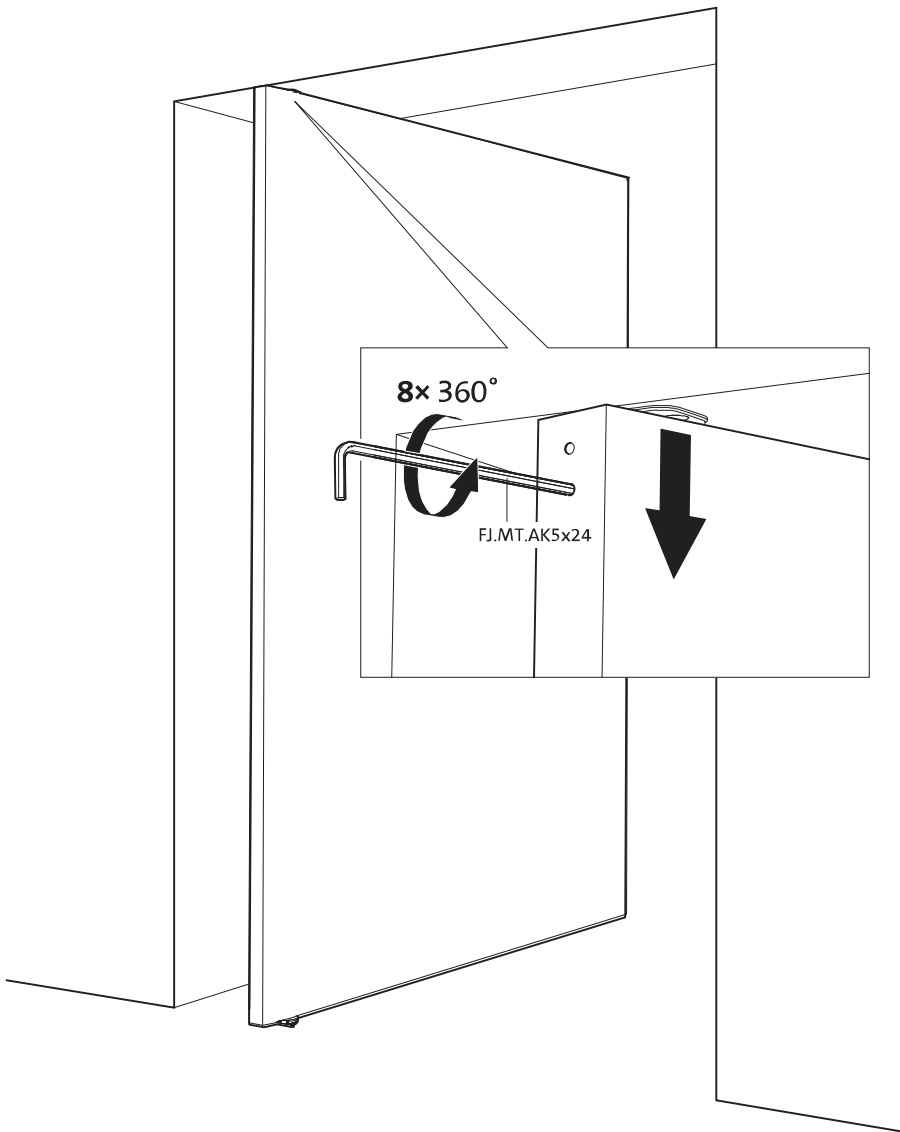

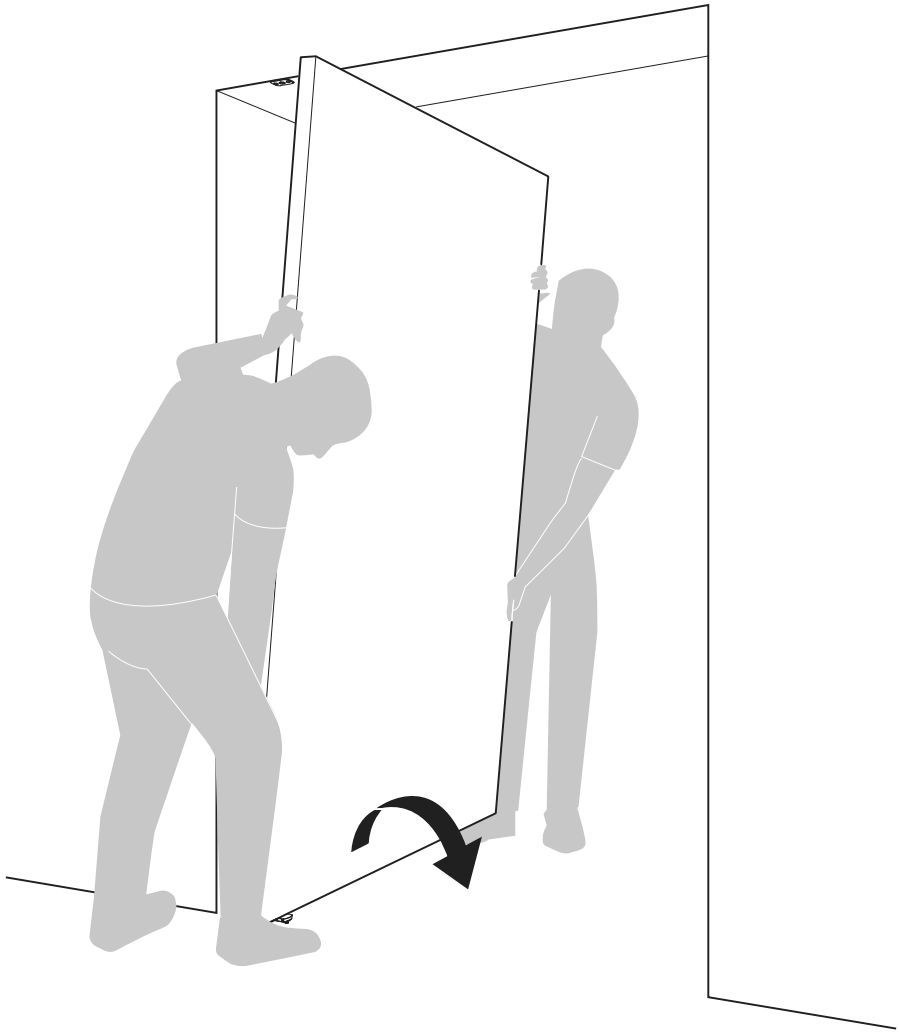



**FritsJurgens International**

A. Einsteinlaan 1

Paesi Bassi

9615 TE Kolham

+31 598 343 410

info@fritsjurgens.com

**FritsJurgens Dubai Branch**

DLC-OP-A2-4-0029

Dubai South

Dubai

Emirati Arabi Uniti

+971 4 820 8106

+971 58 137 2611

dubai@fritsjurgens.com

fritsjurgens.com

Copyright © FritsJurgens®  
BPM+.70.C.X.XX



8 719325 750607

