

System M+

Manual de fresagem e montagem

FritsJurgens Kit - 40 mm Classe G - aço inoxidável

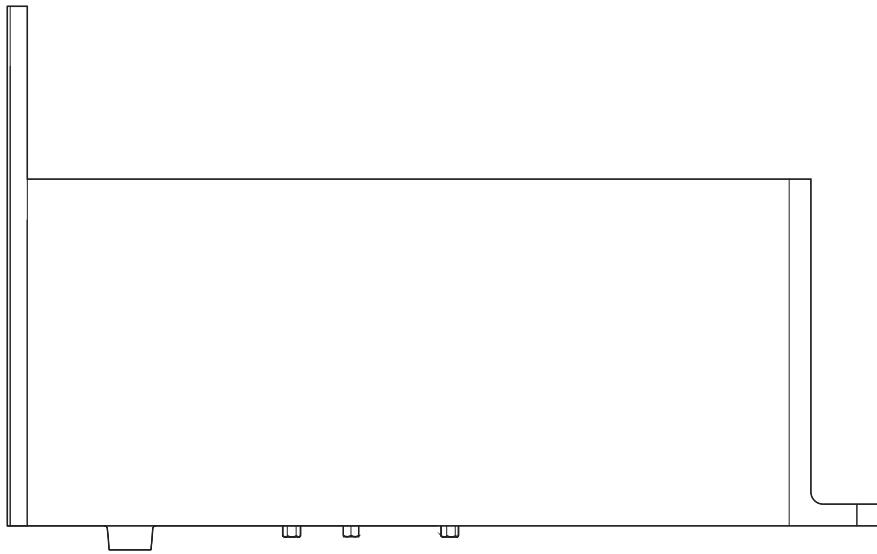

FritsJurgens®

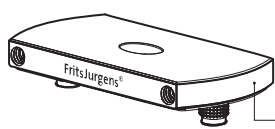
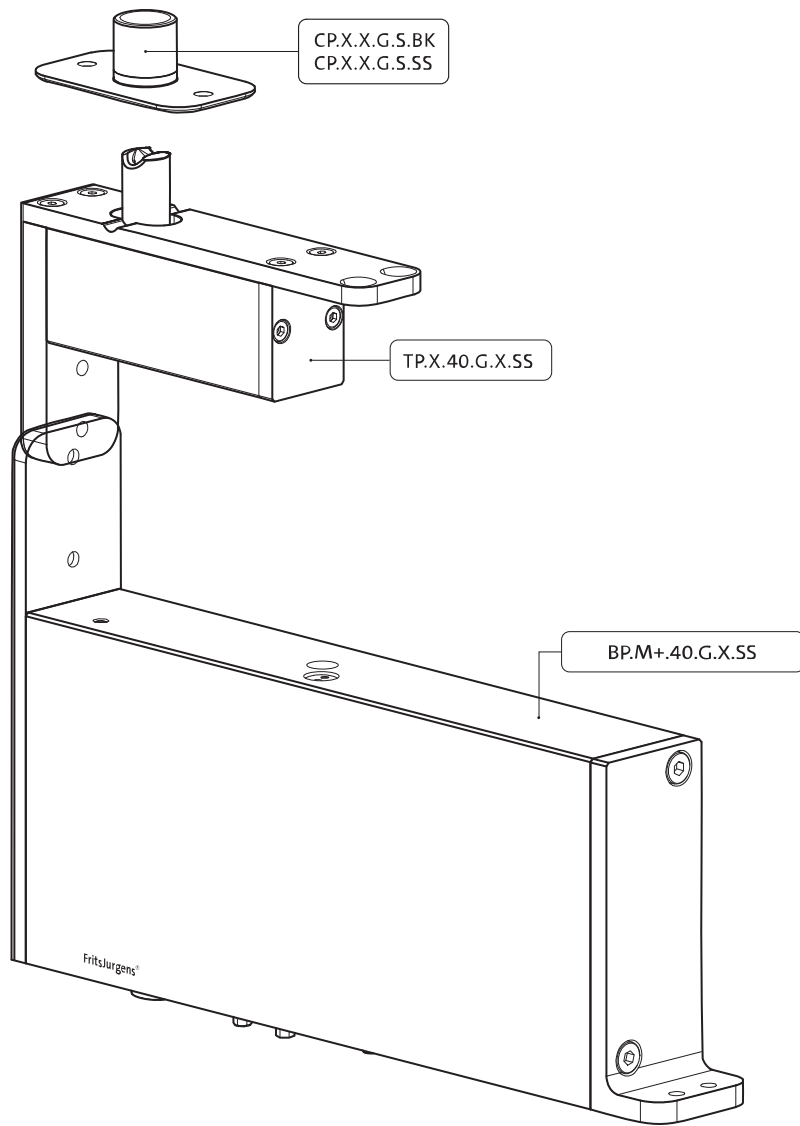

FP.M.X.X.S.BK
FP.M.X.X.S.SS



FP.M.X.X.FS.SS



FP.M.X.X.FR.SS



FP.M.X.X.R.SS
FP.M.X.X.R.BK

Instruções de fresagem

BP.M+.40.G.X.SS

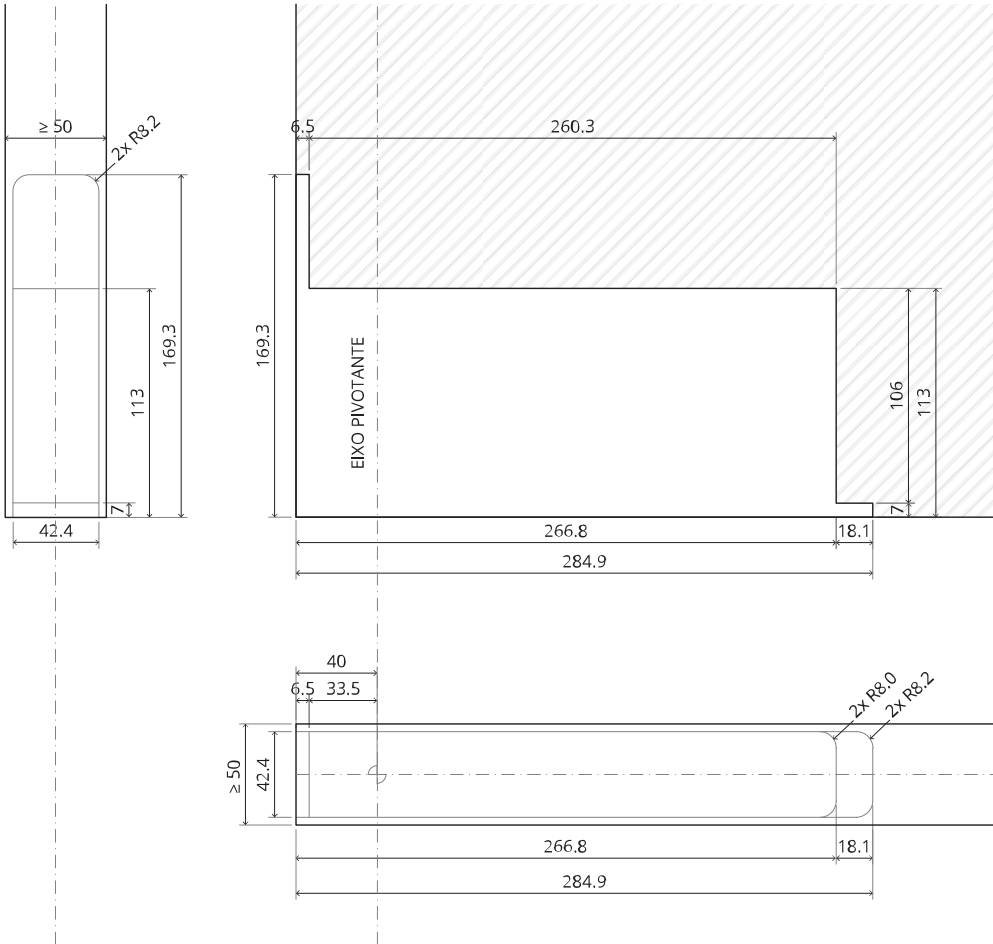

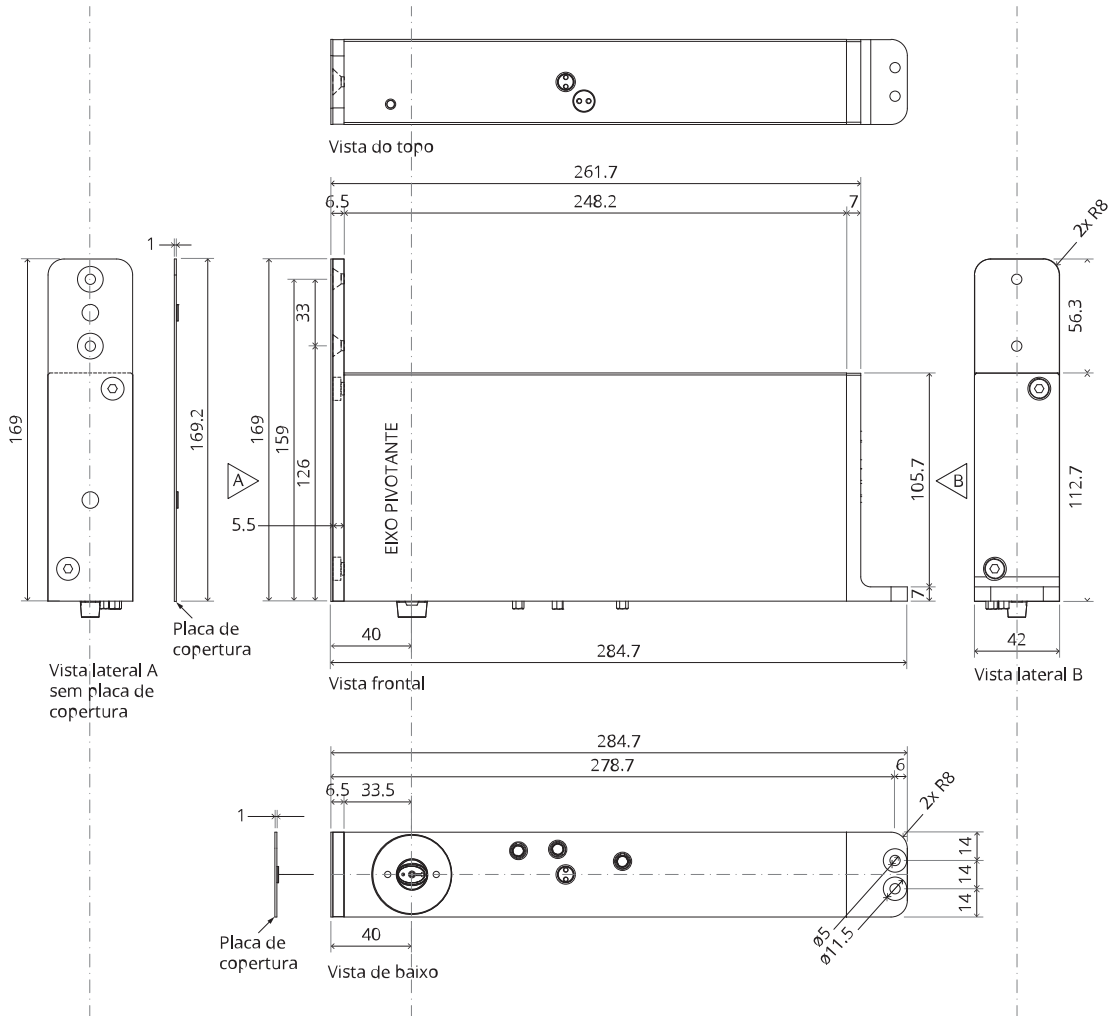

TP.X.40.G.X.SS

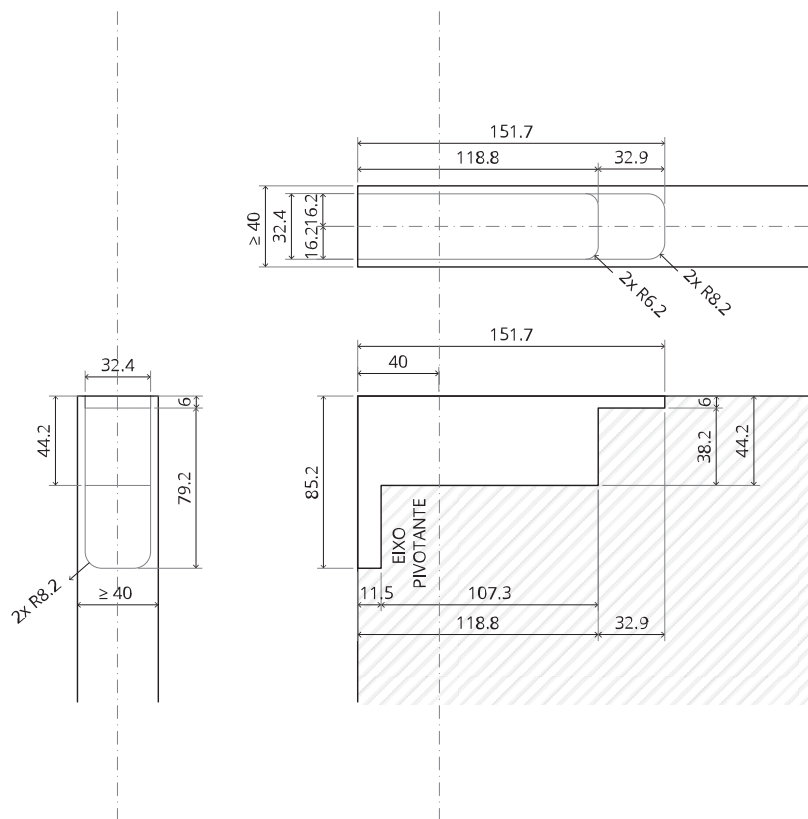

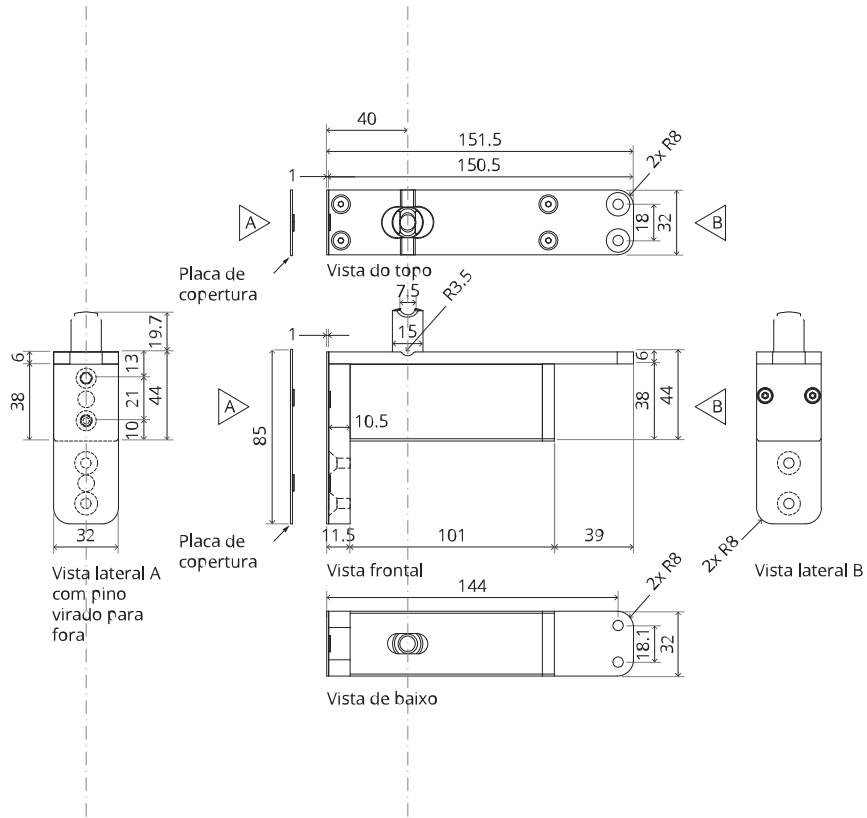

FP.M.X.X.FS.SS

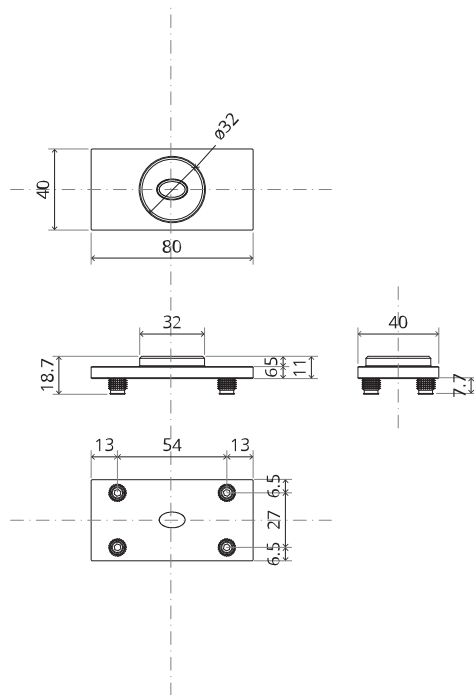
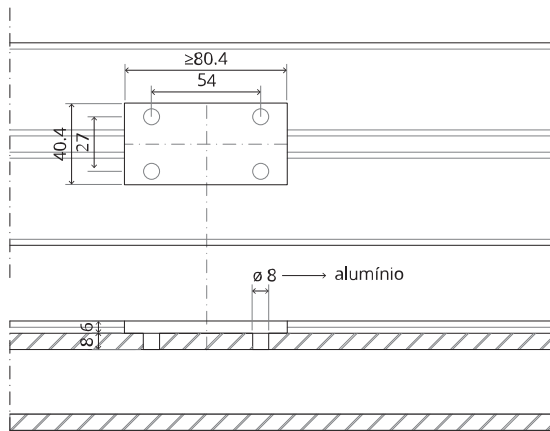

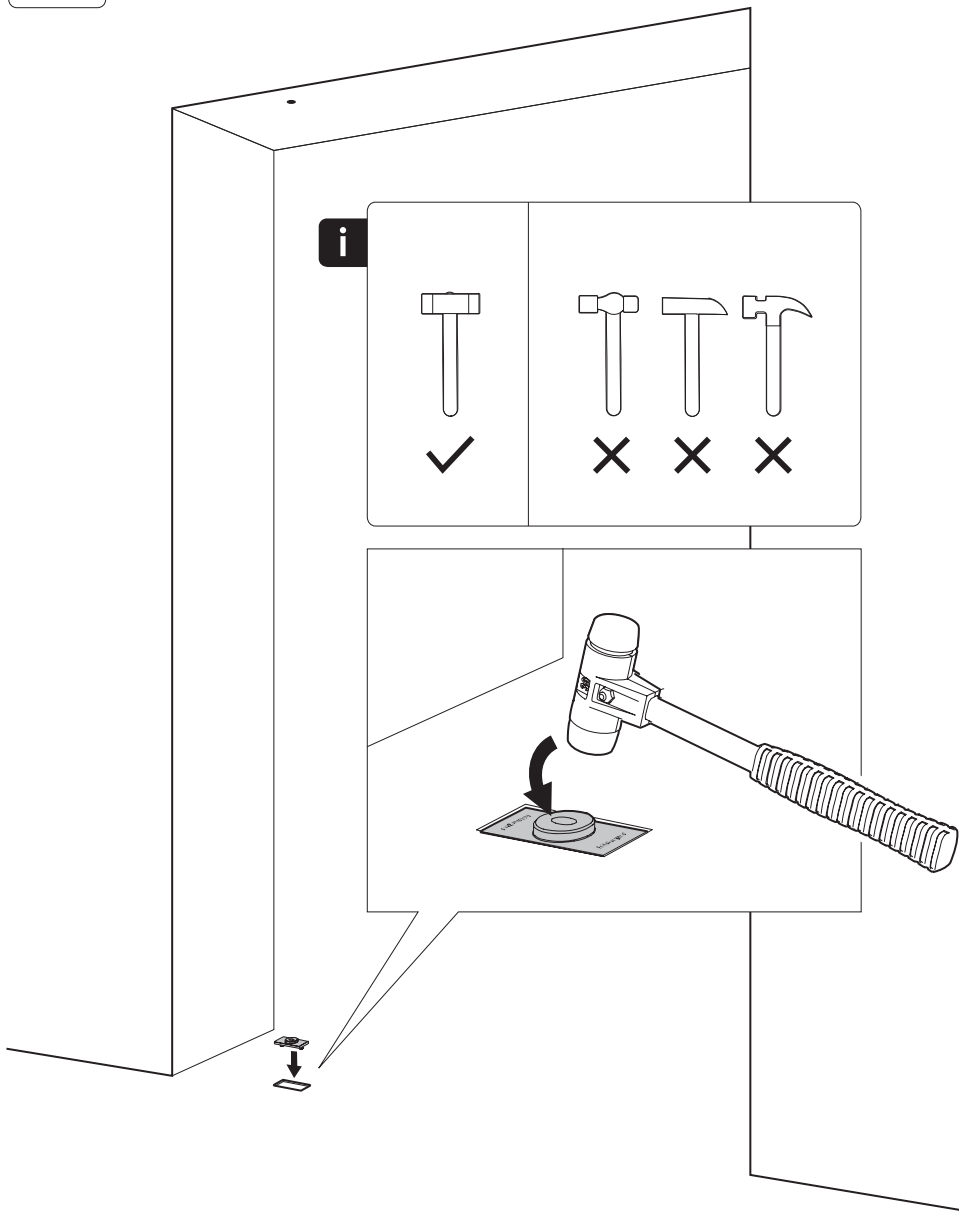

FP.M.X.X.FR.SS

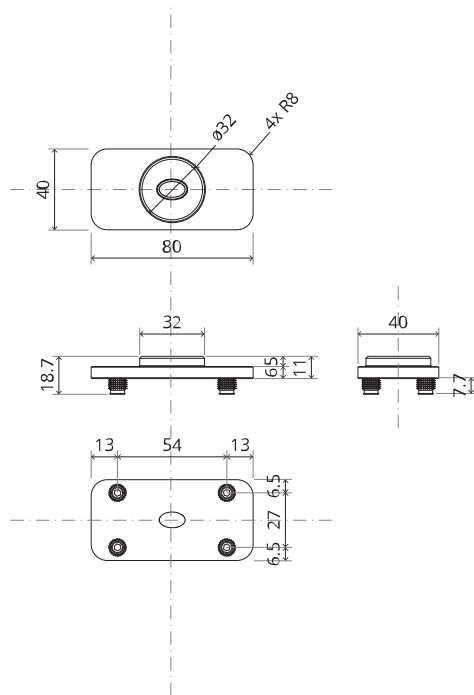
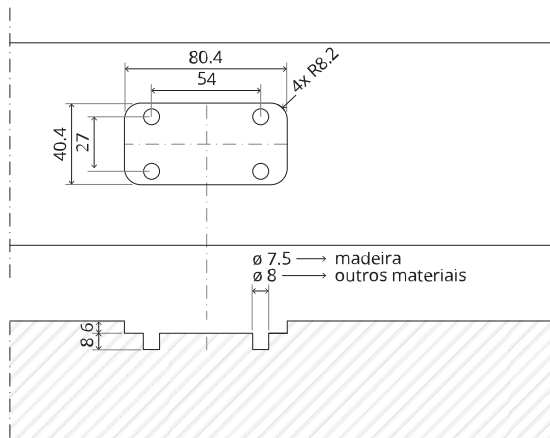

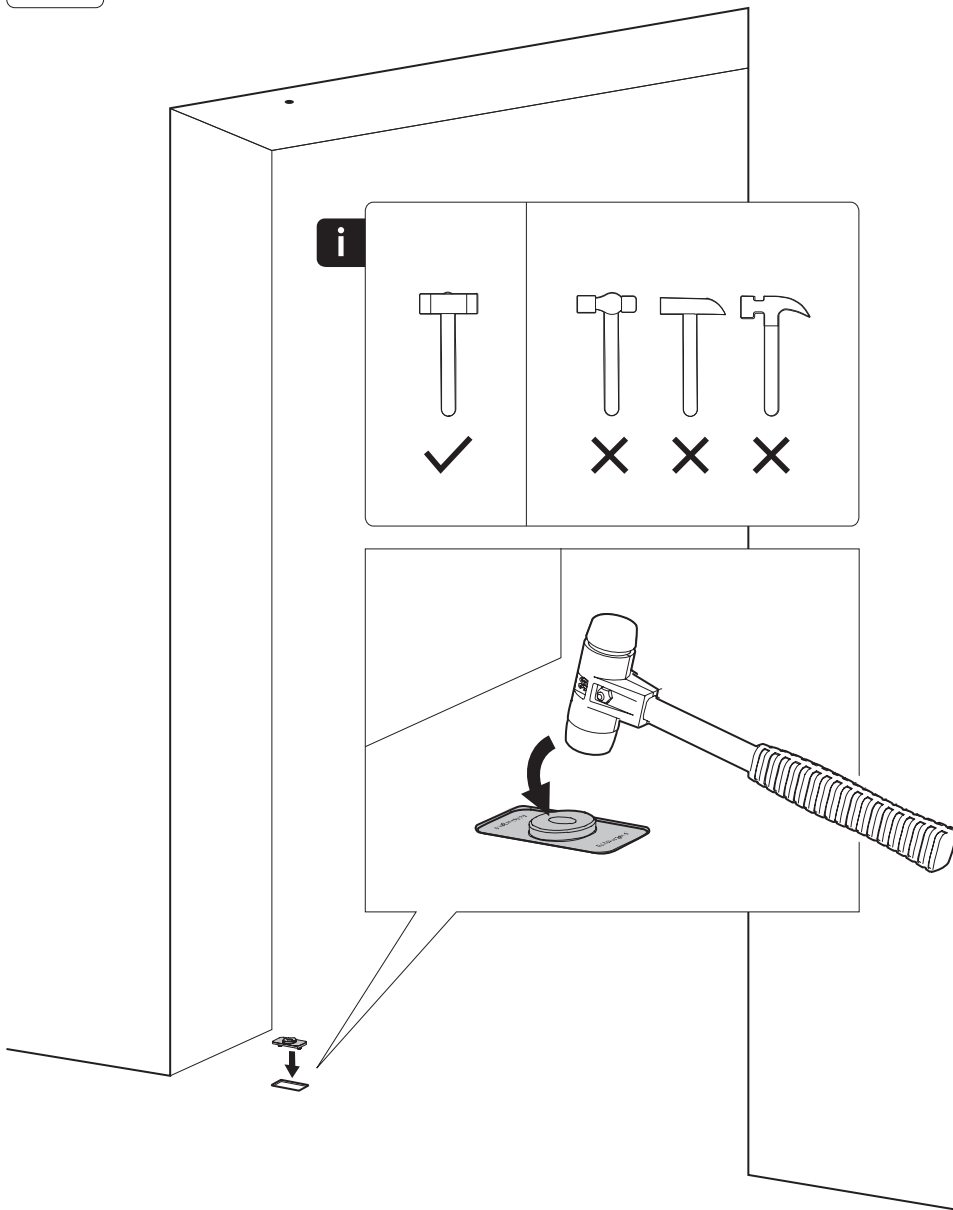
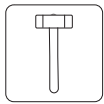

Instruções de montagem

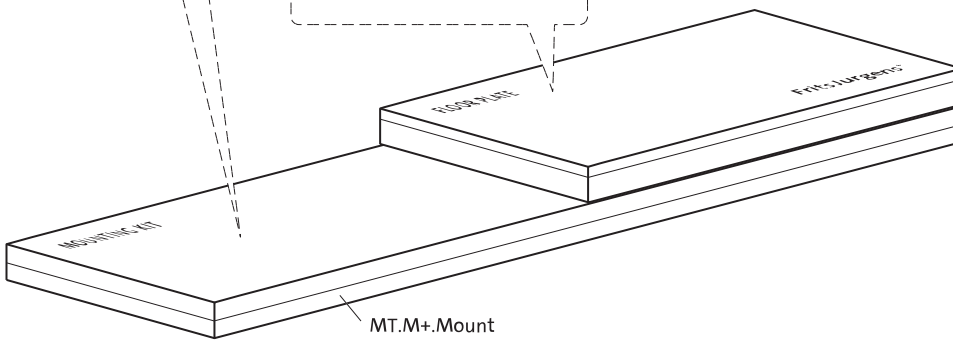
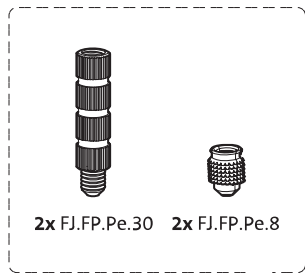
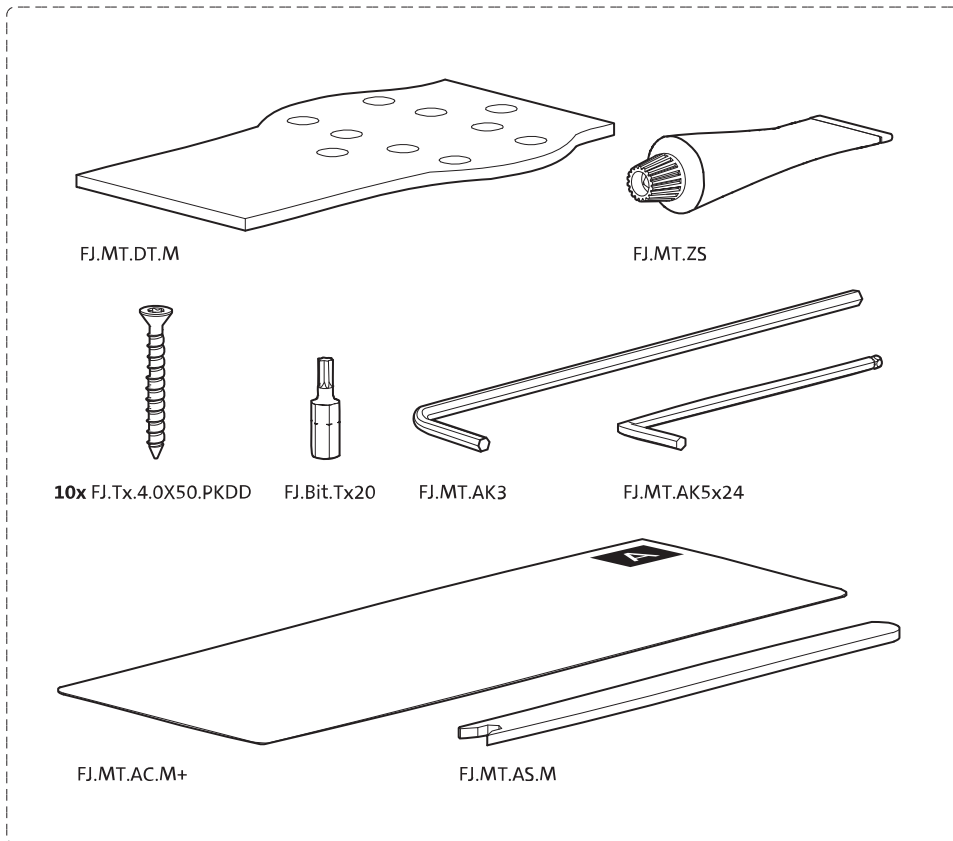

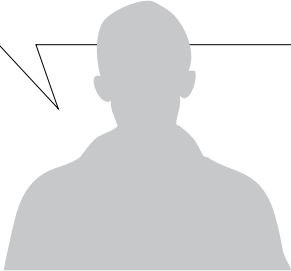
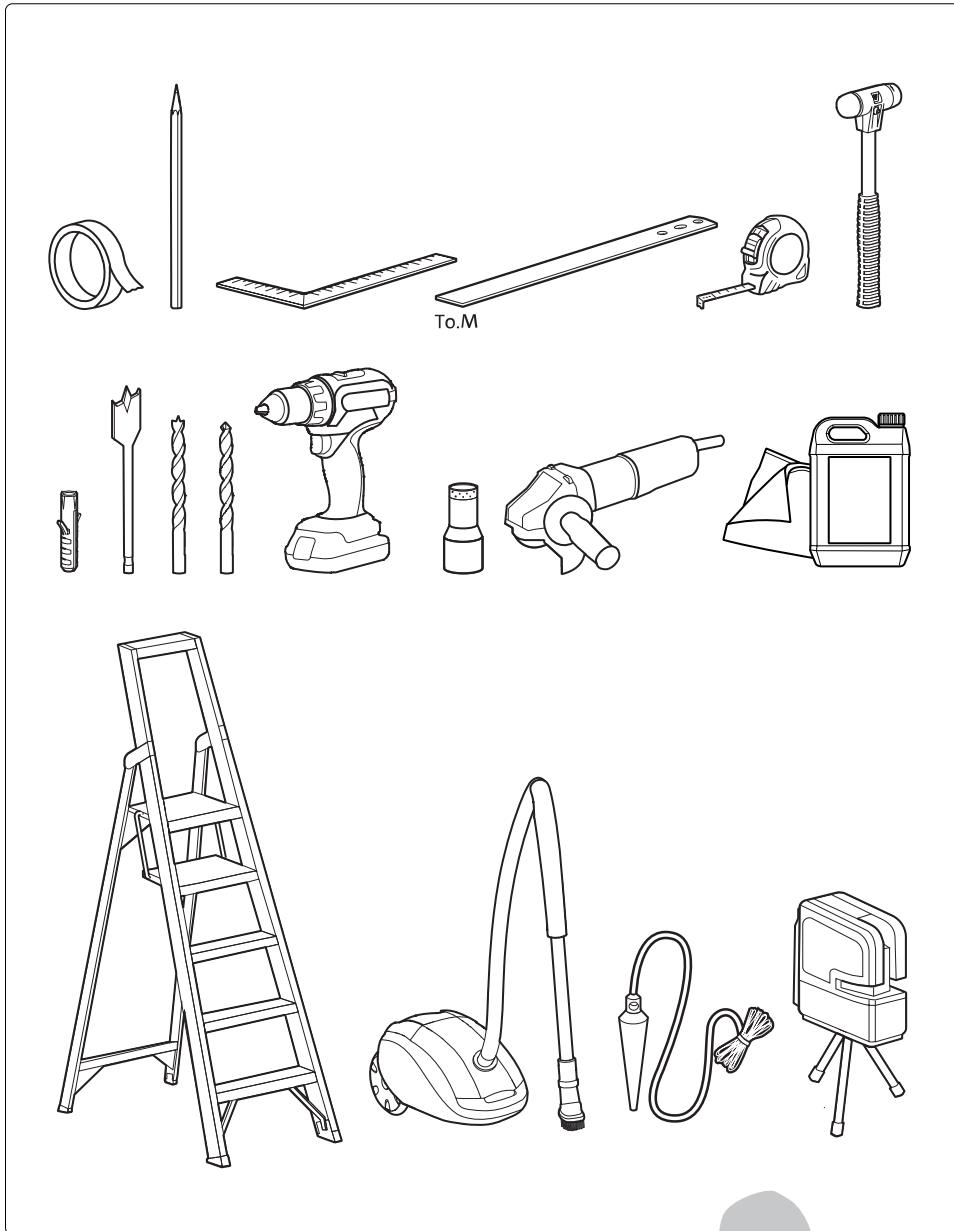

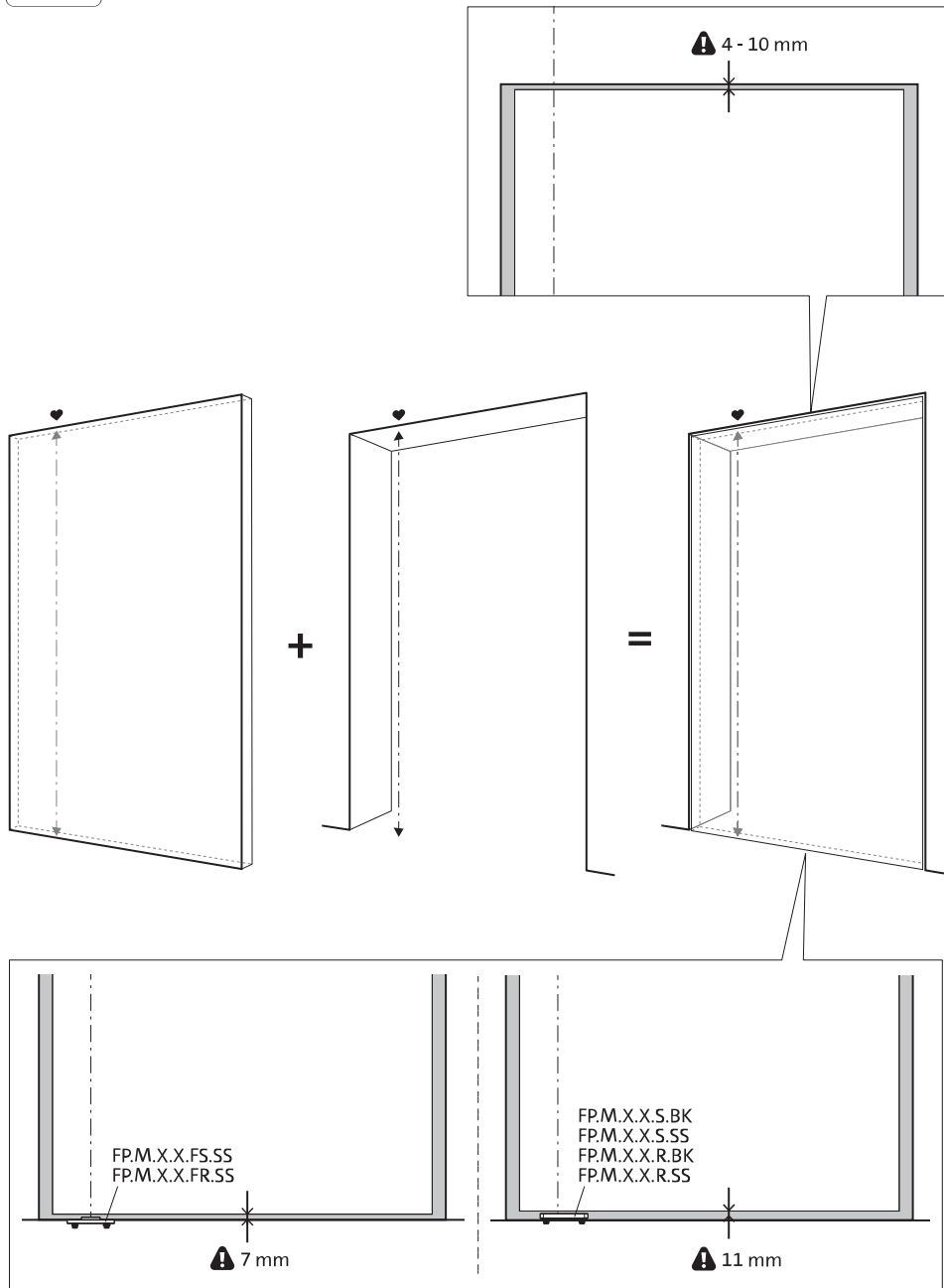

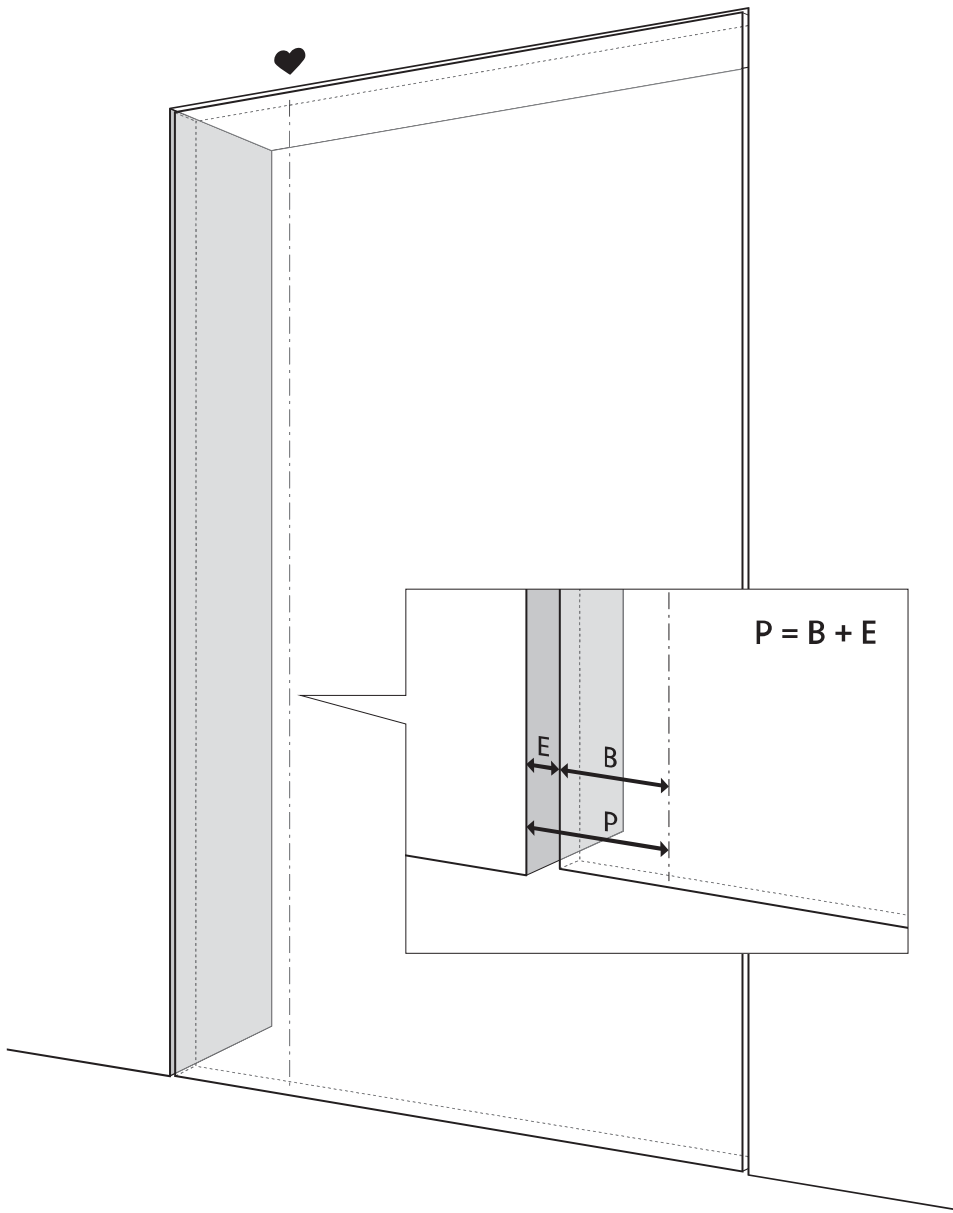

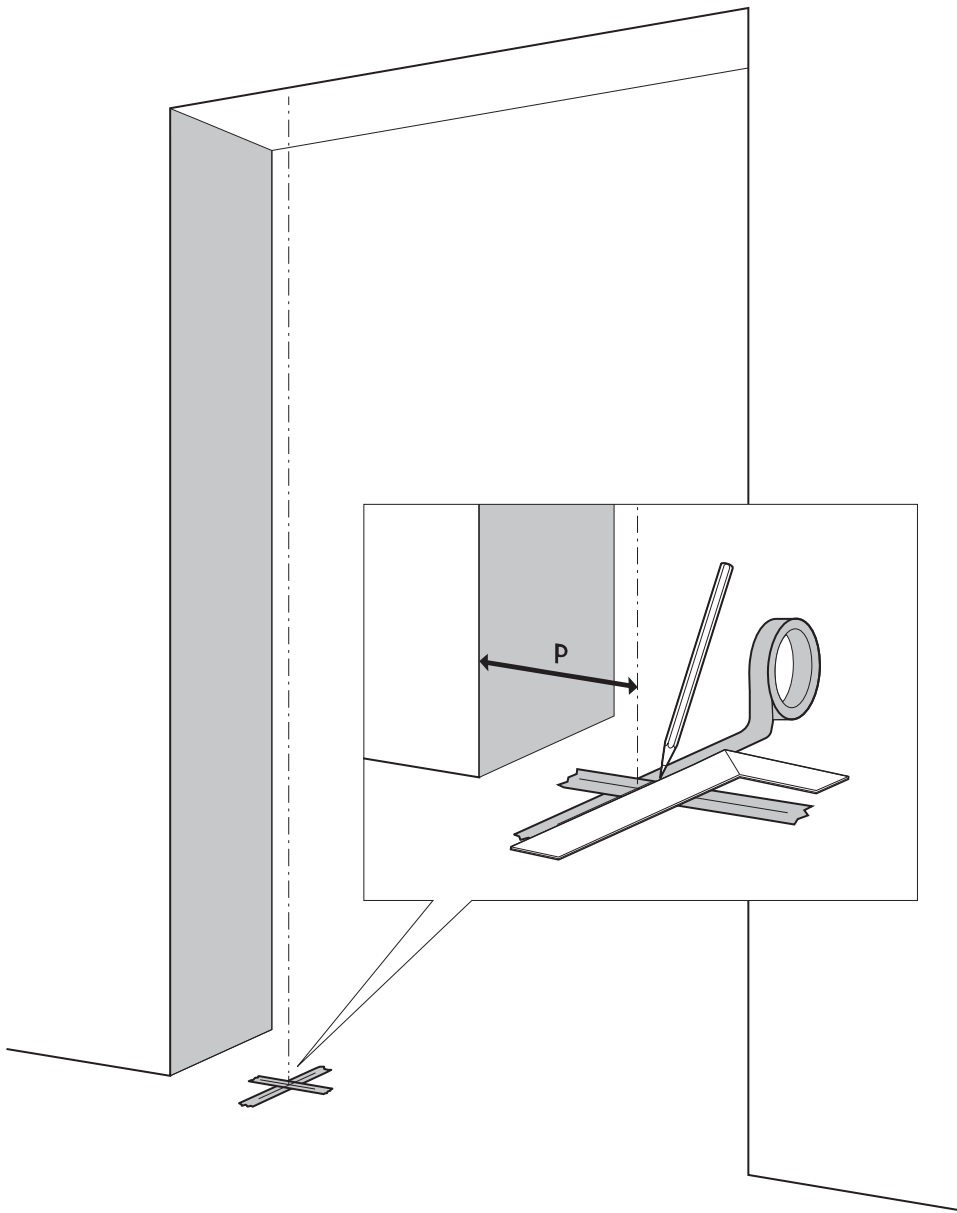

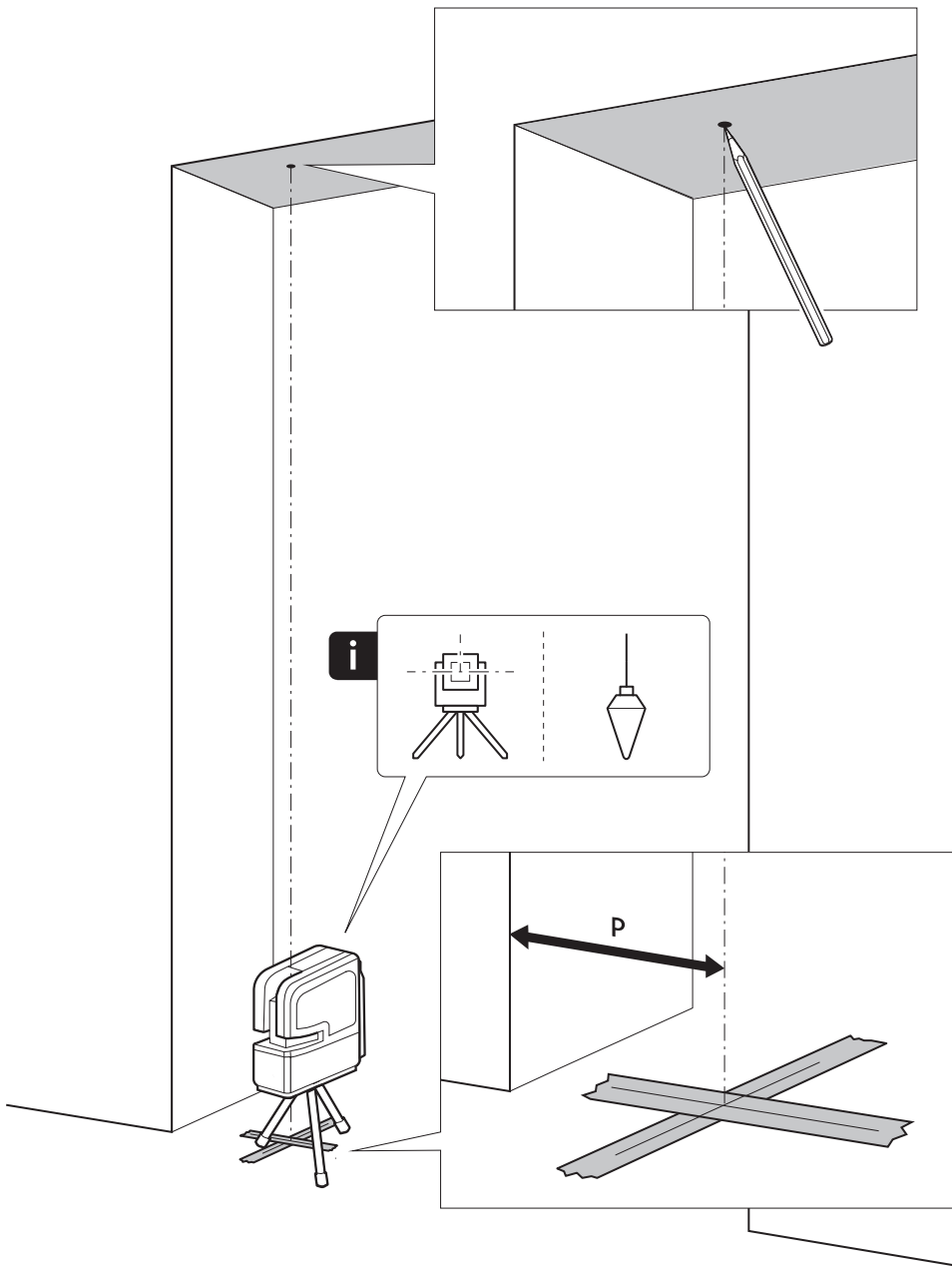
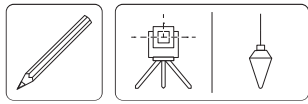

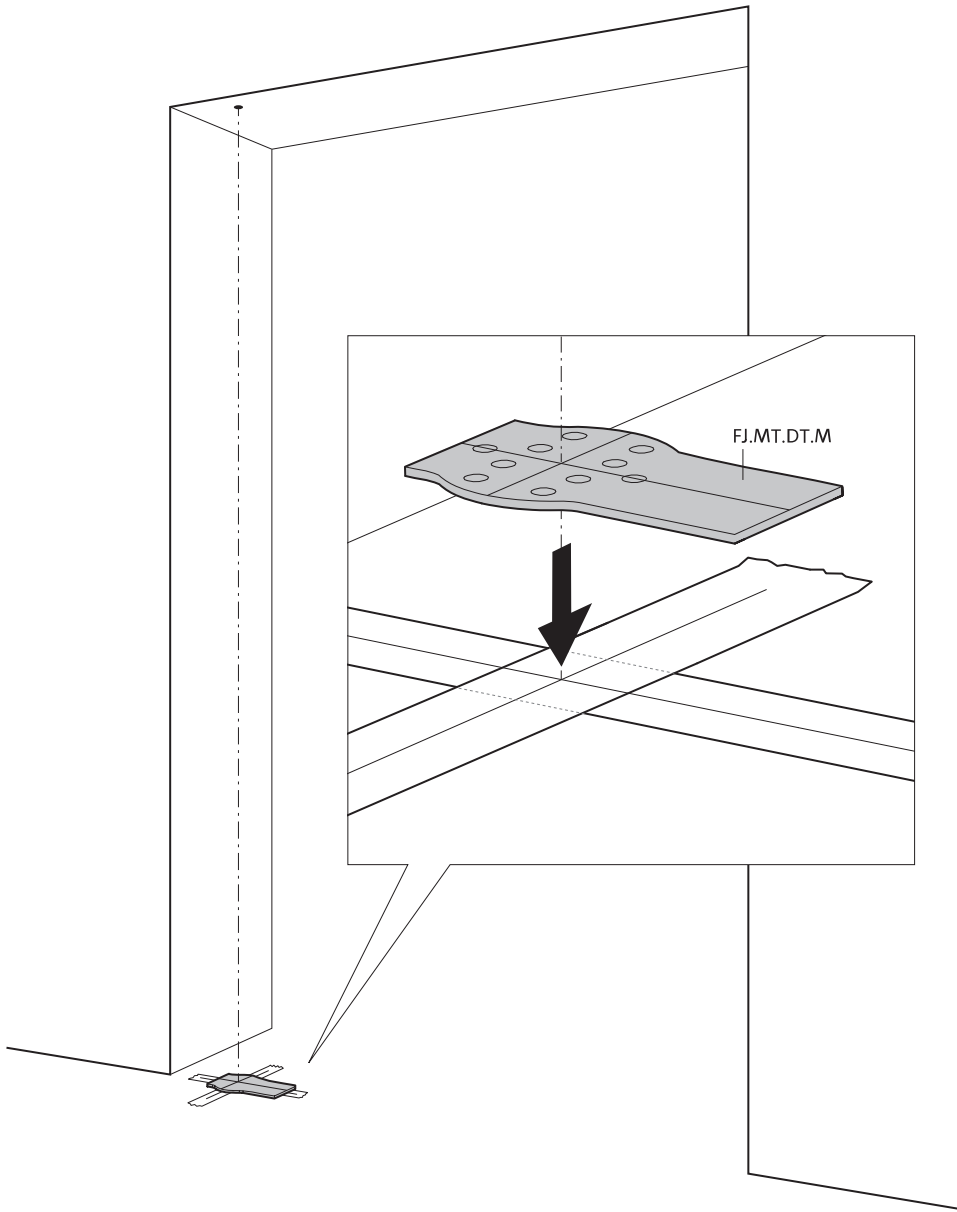

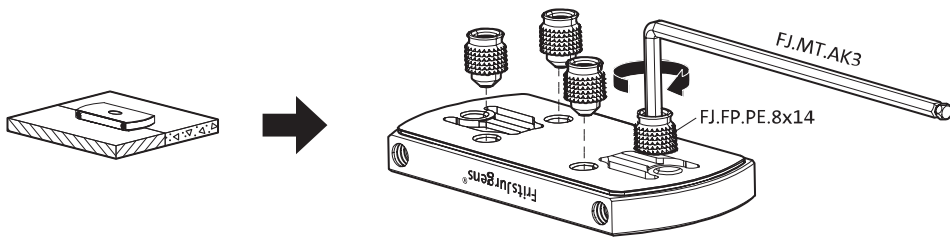
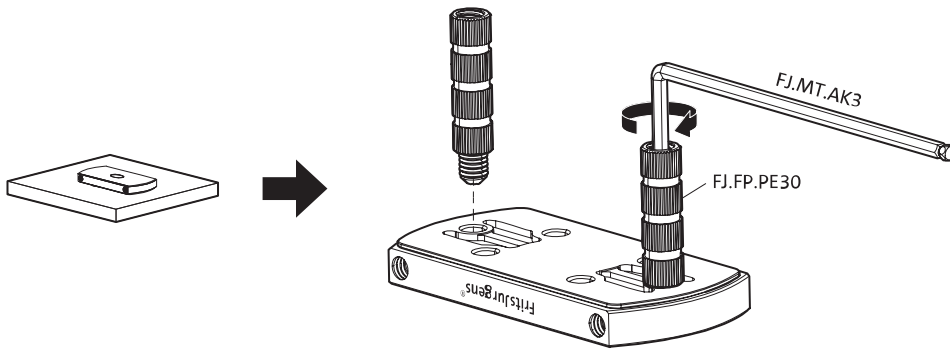
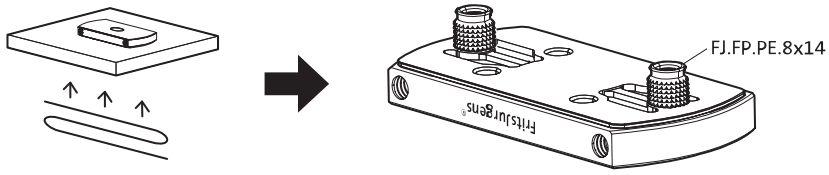



ø8 mm (5/16")

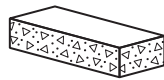

ø8 mm (5/16")

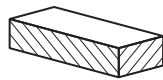

ø7.5 mm (19/64")

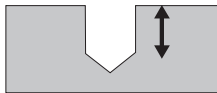

8 mm (5/16")

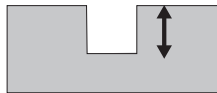

8 mm (5/16")

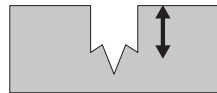

8 mm (5/16")

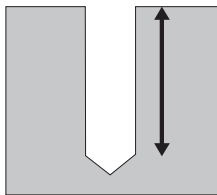

30 mm (13/16")

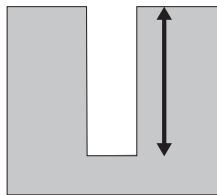

30 mm (13/16")

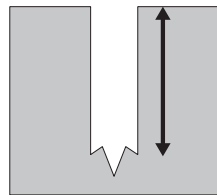

30 mm (13/16")

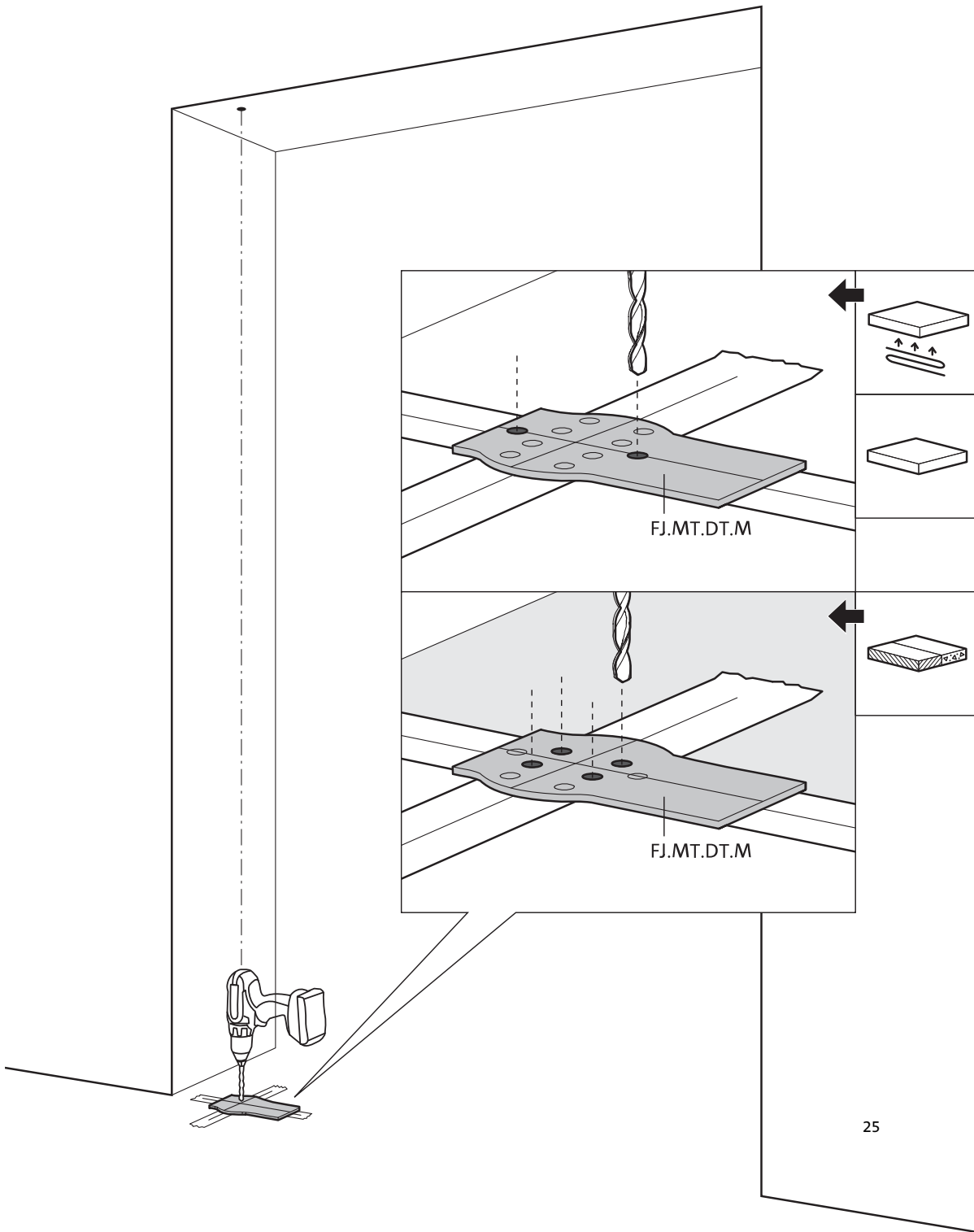

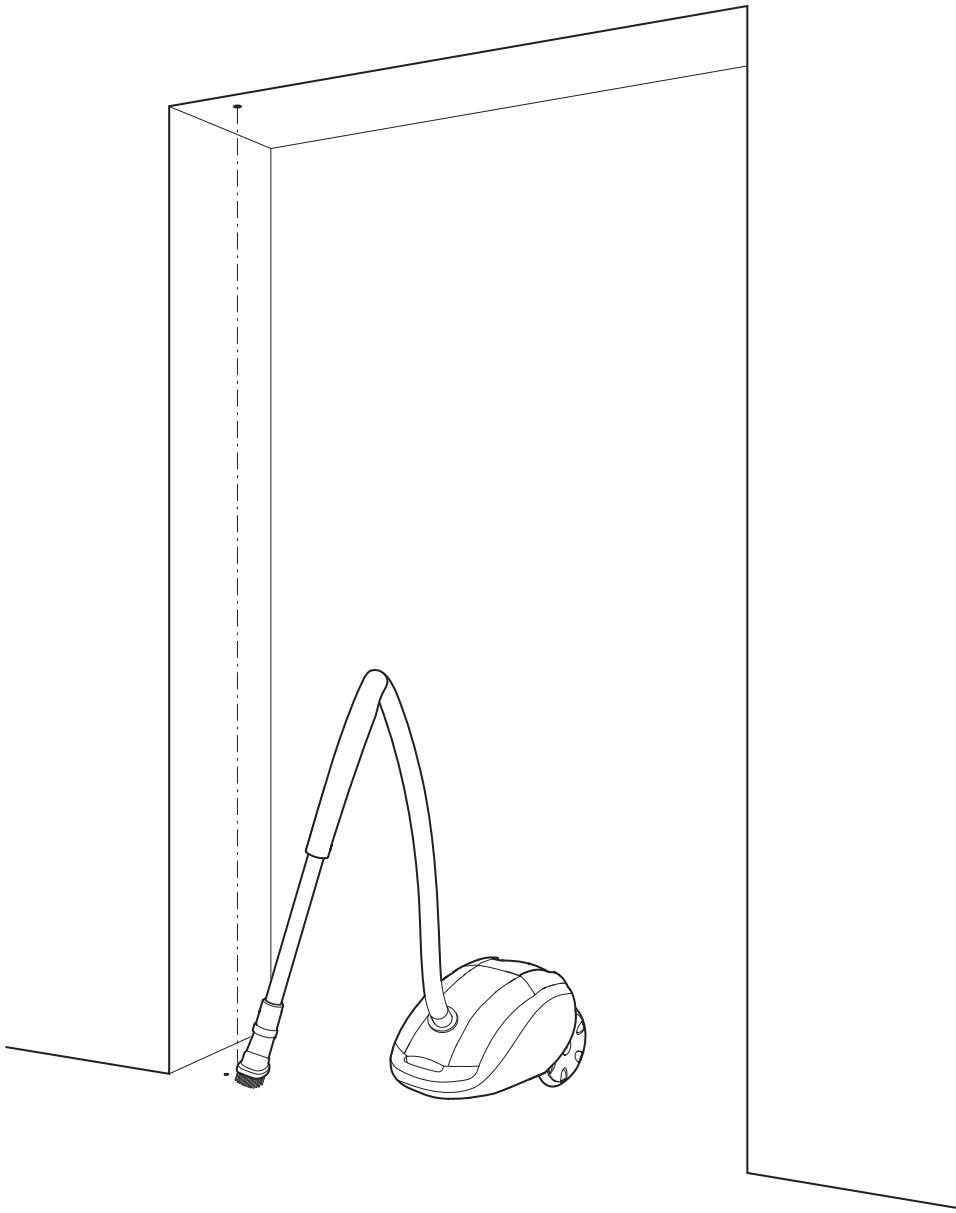



1

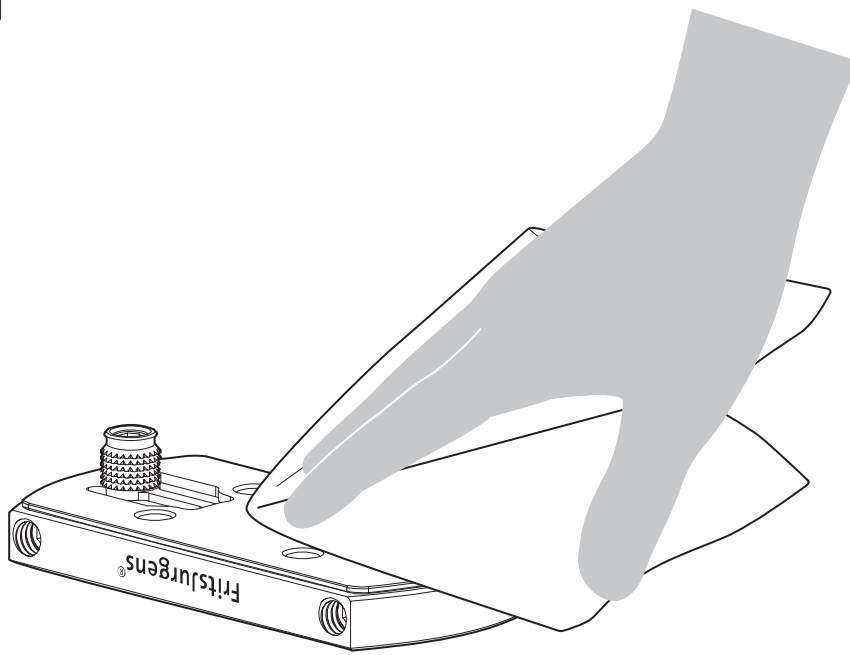

2

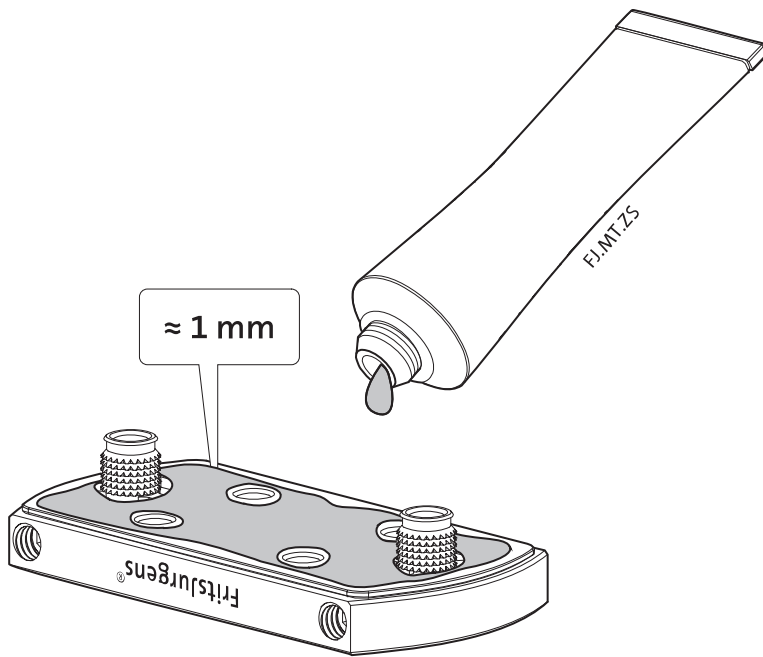

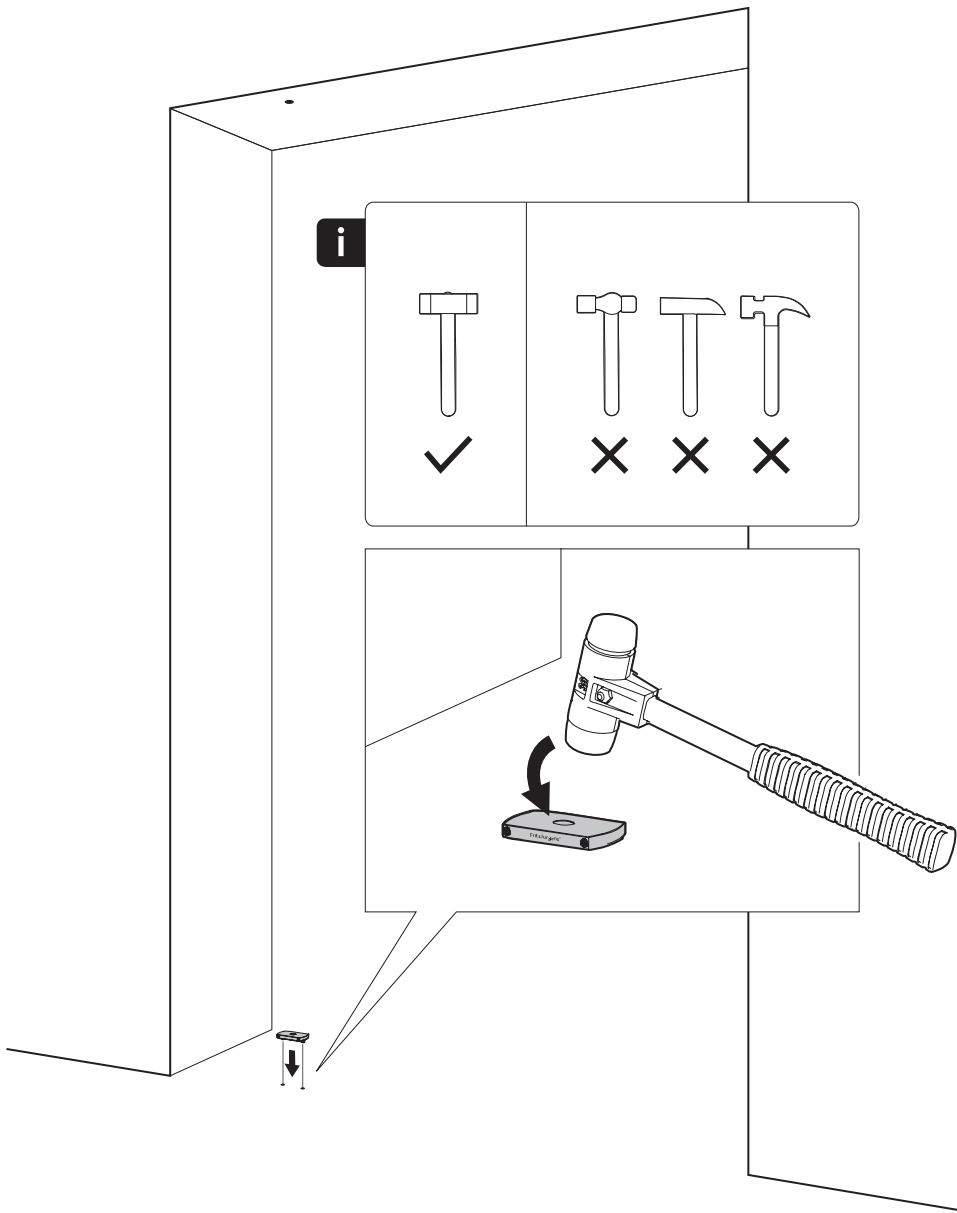
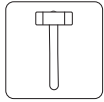

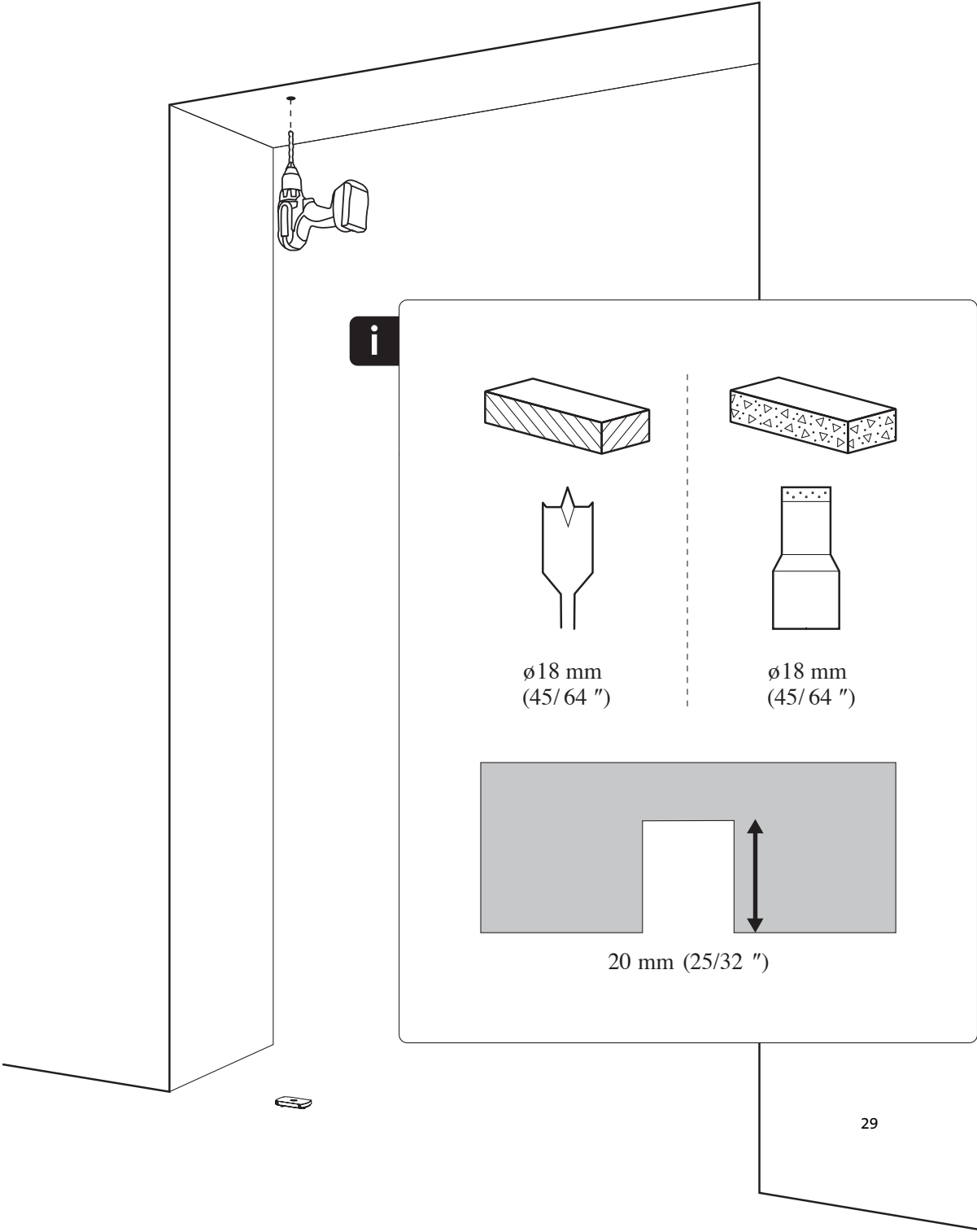
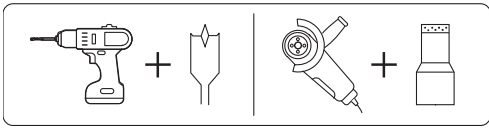



1

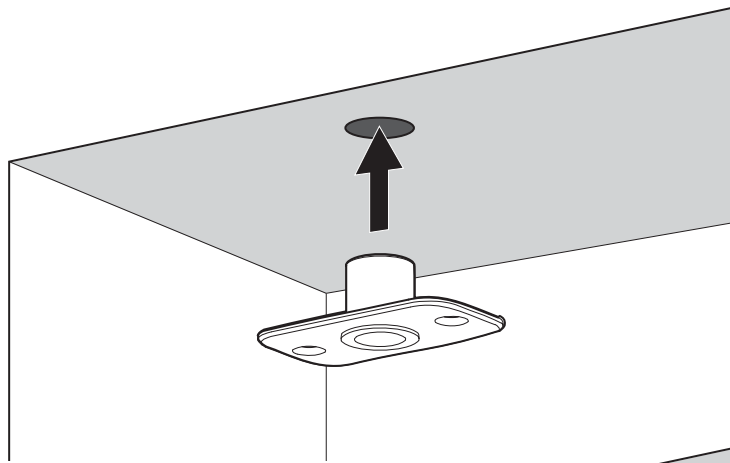

2

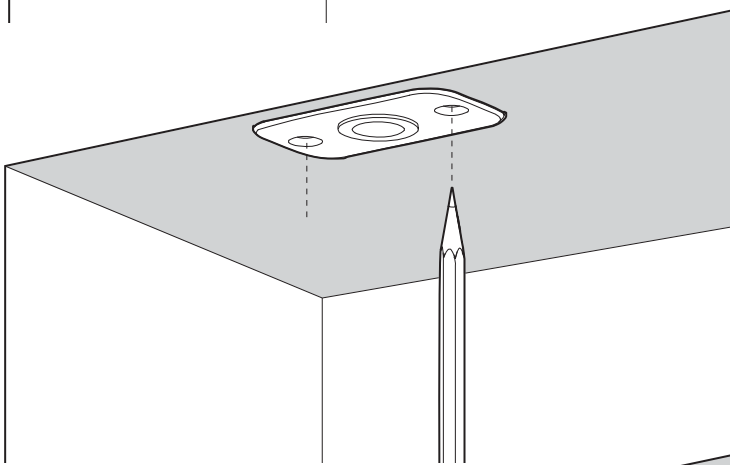

3

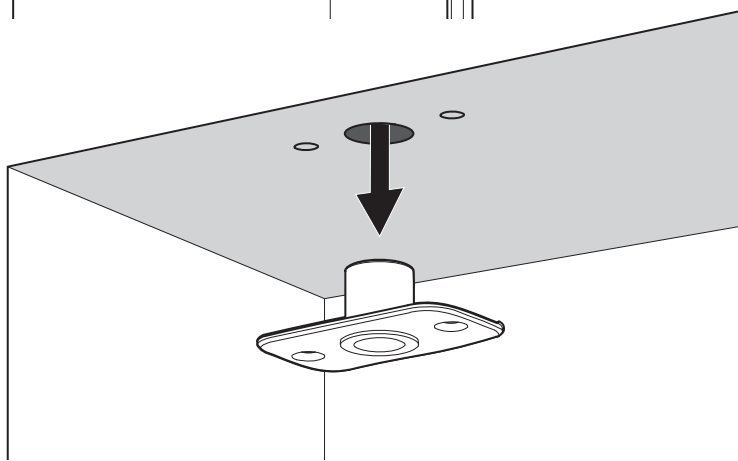



1

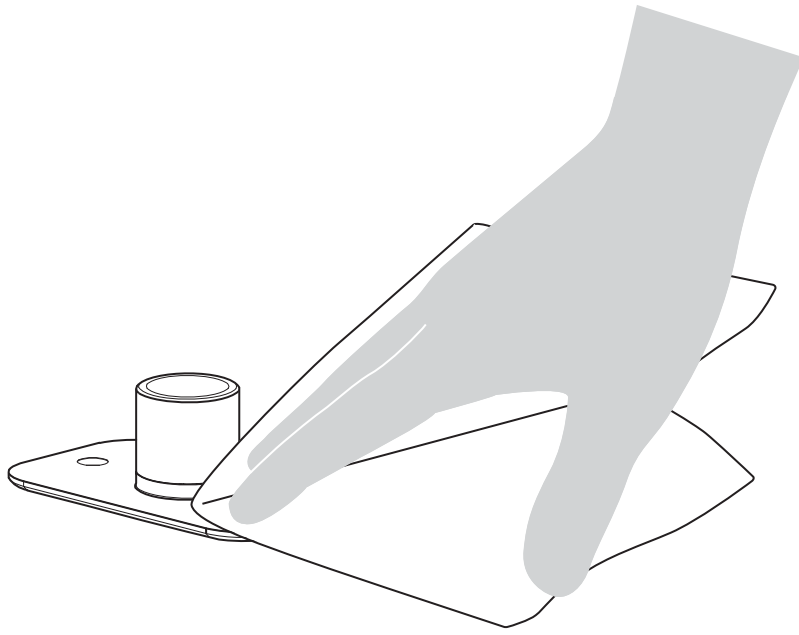

2

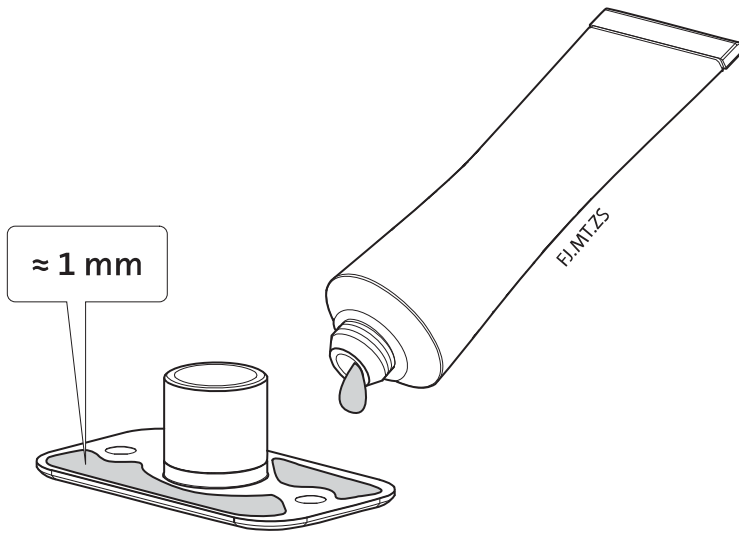

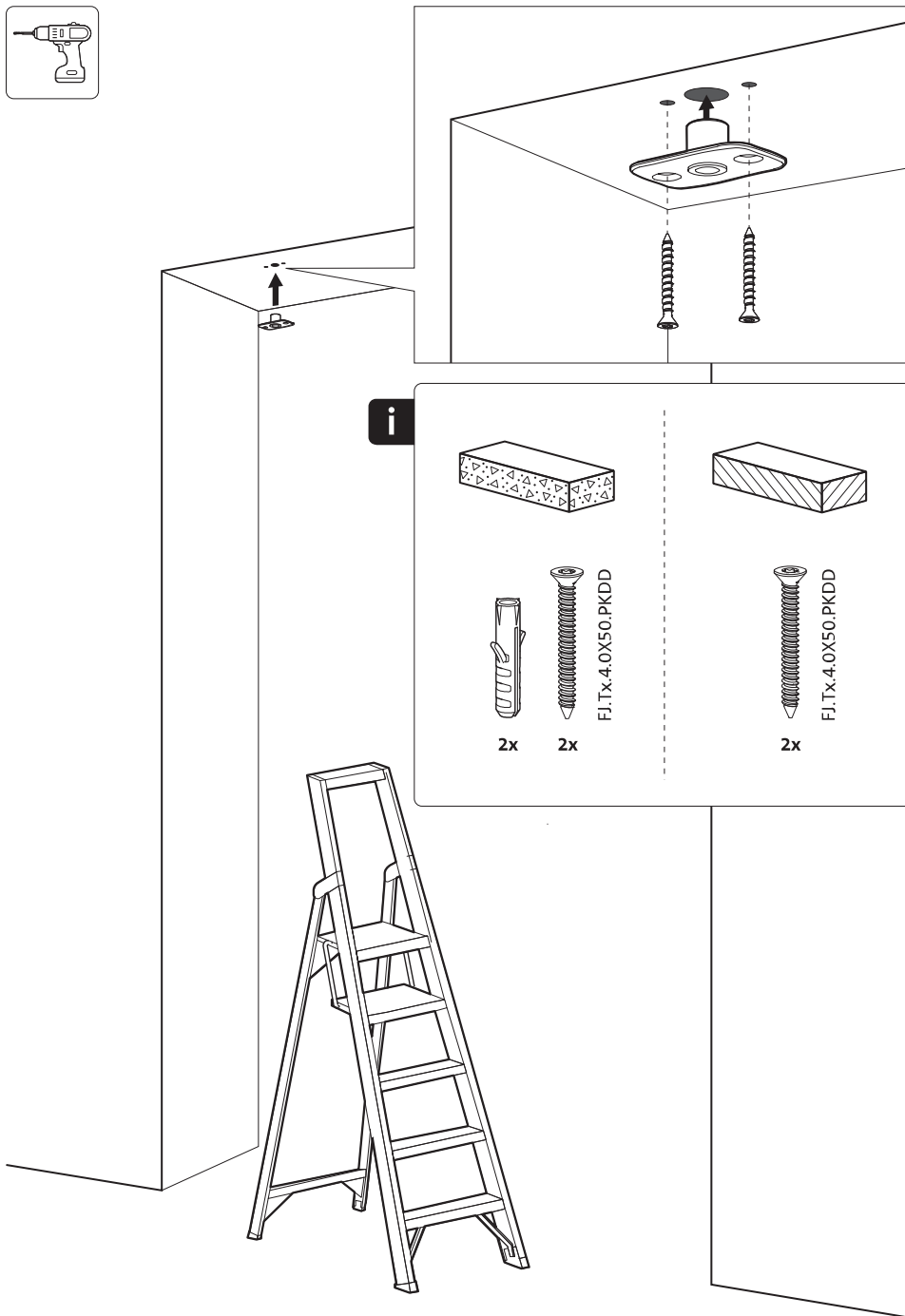

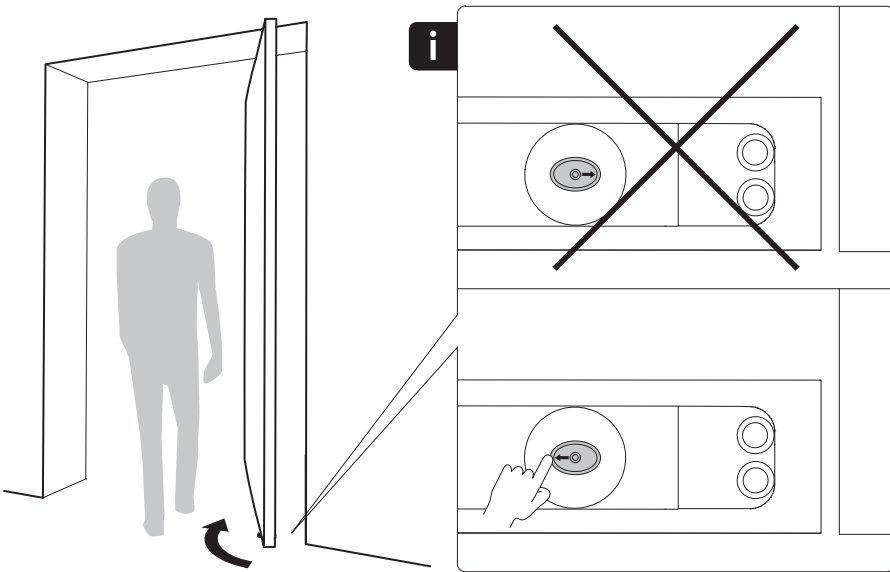
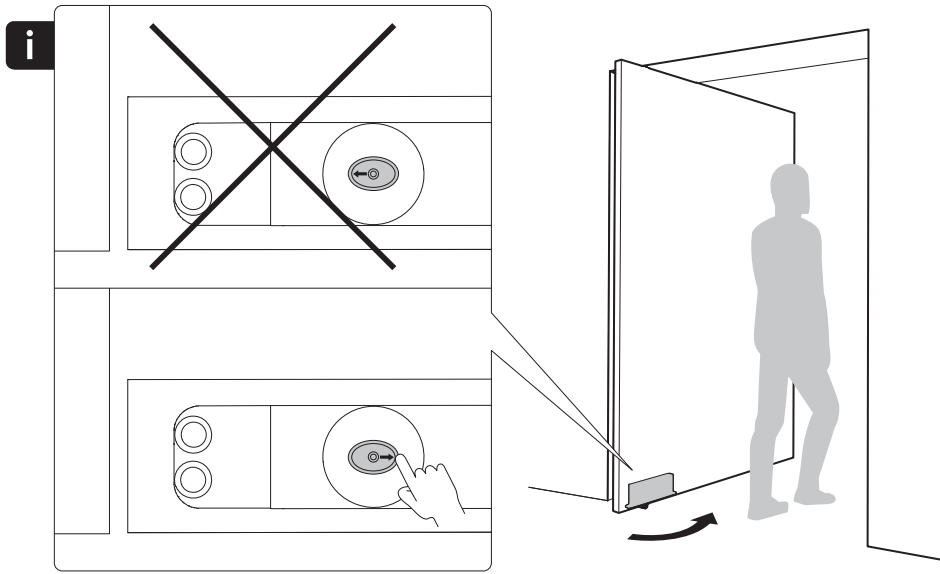

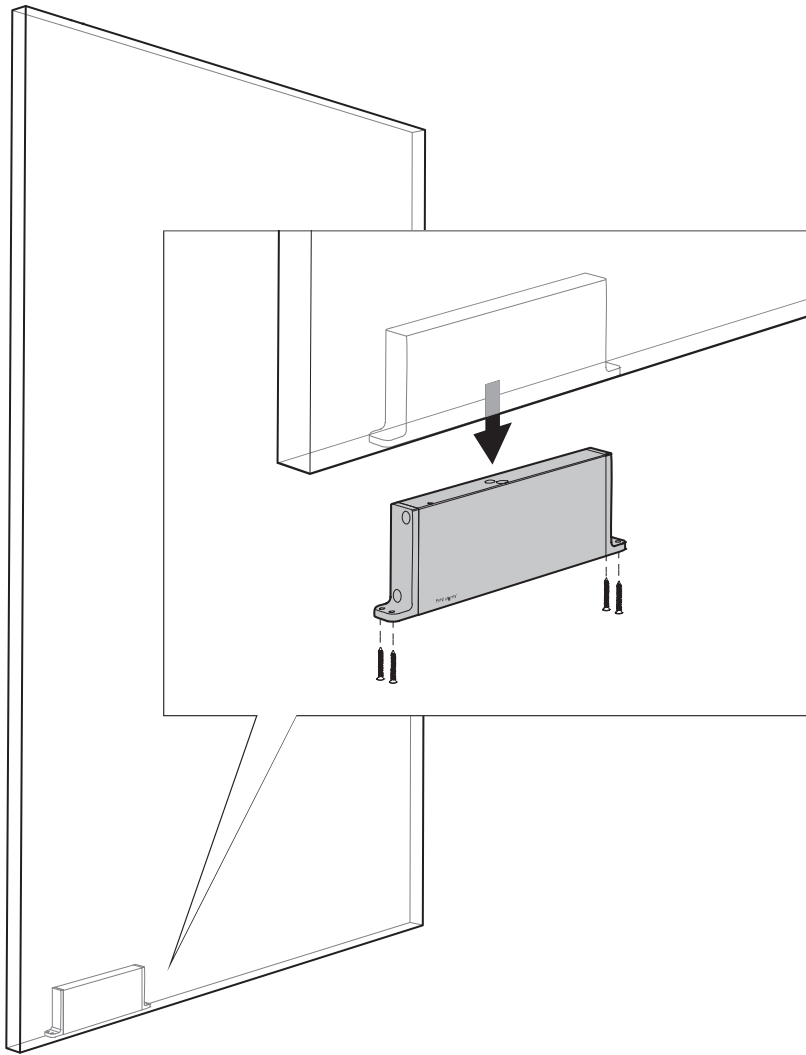

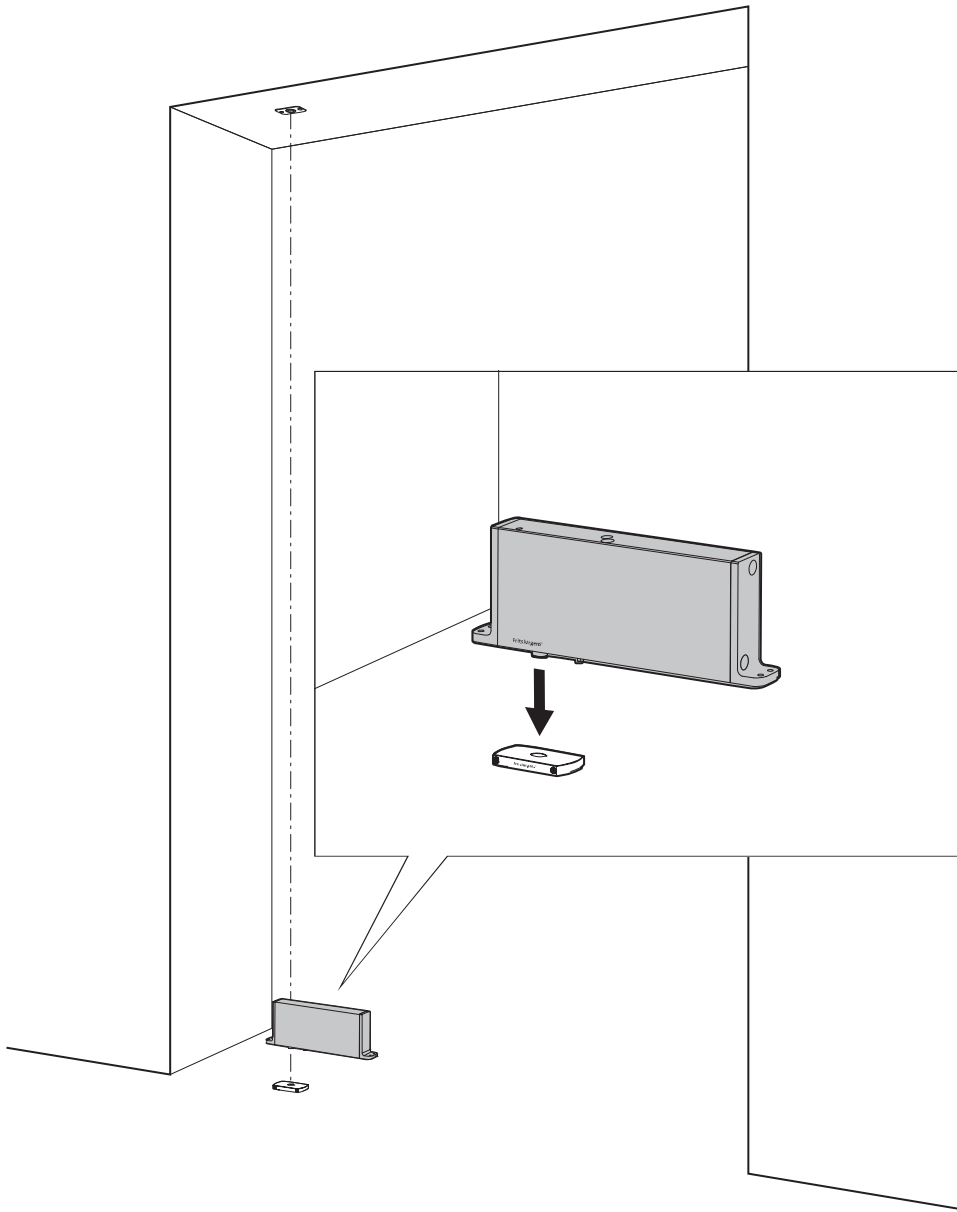

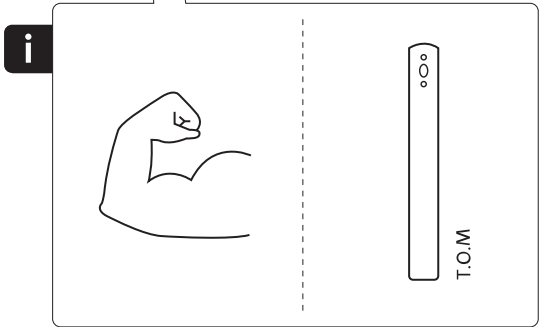
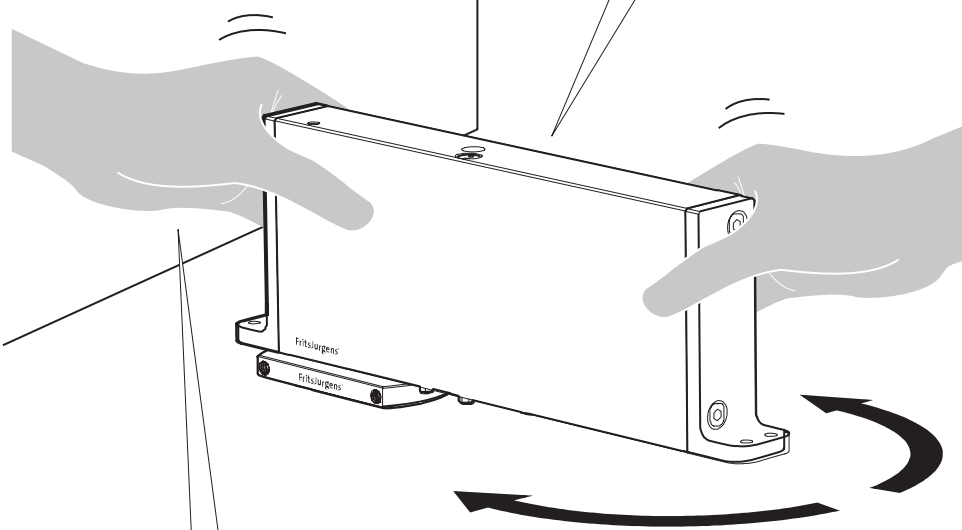
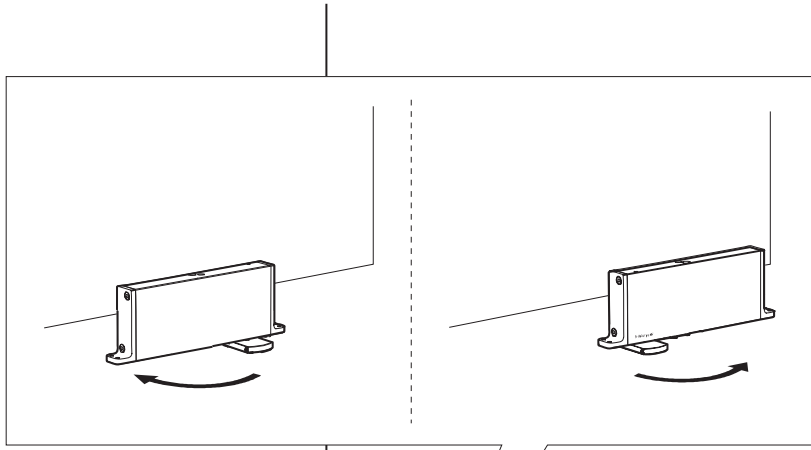

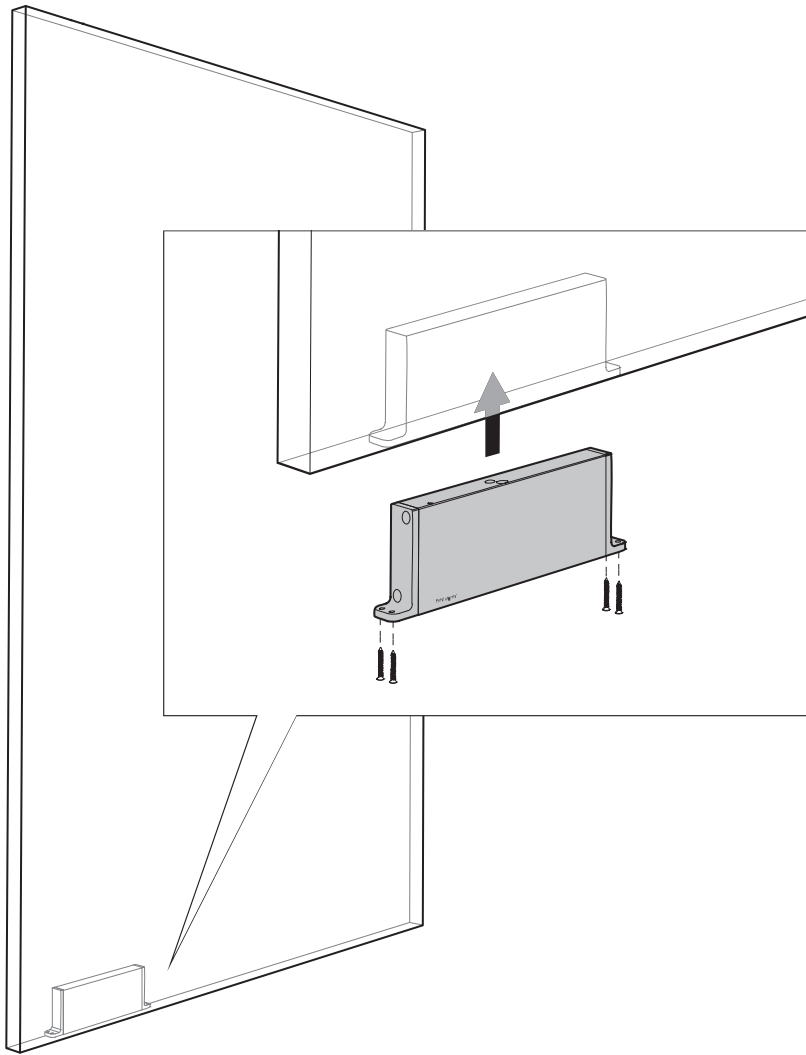

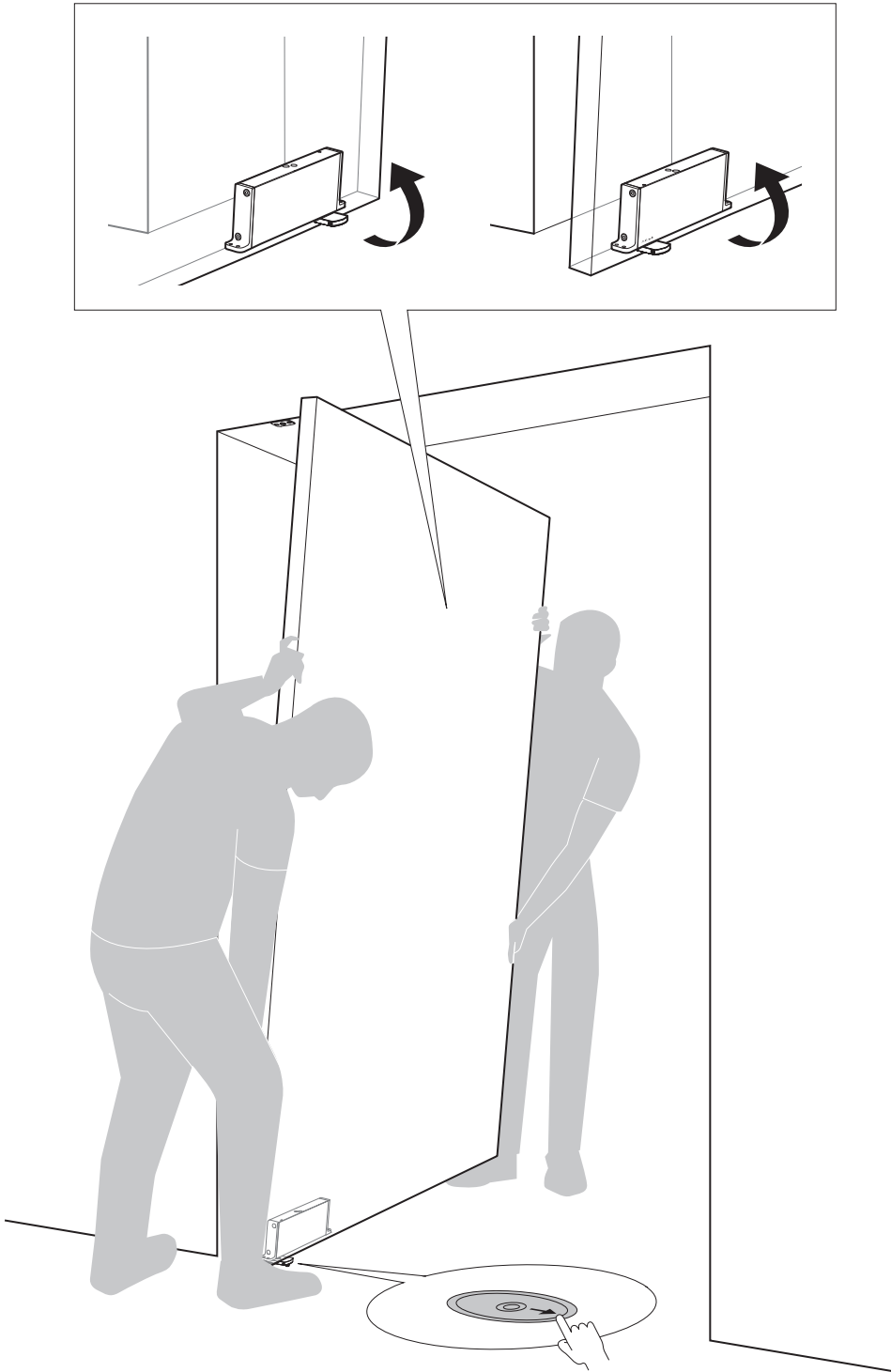

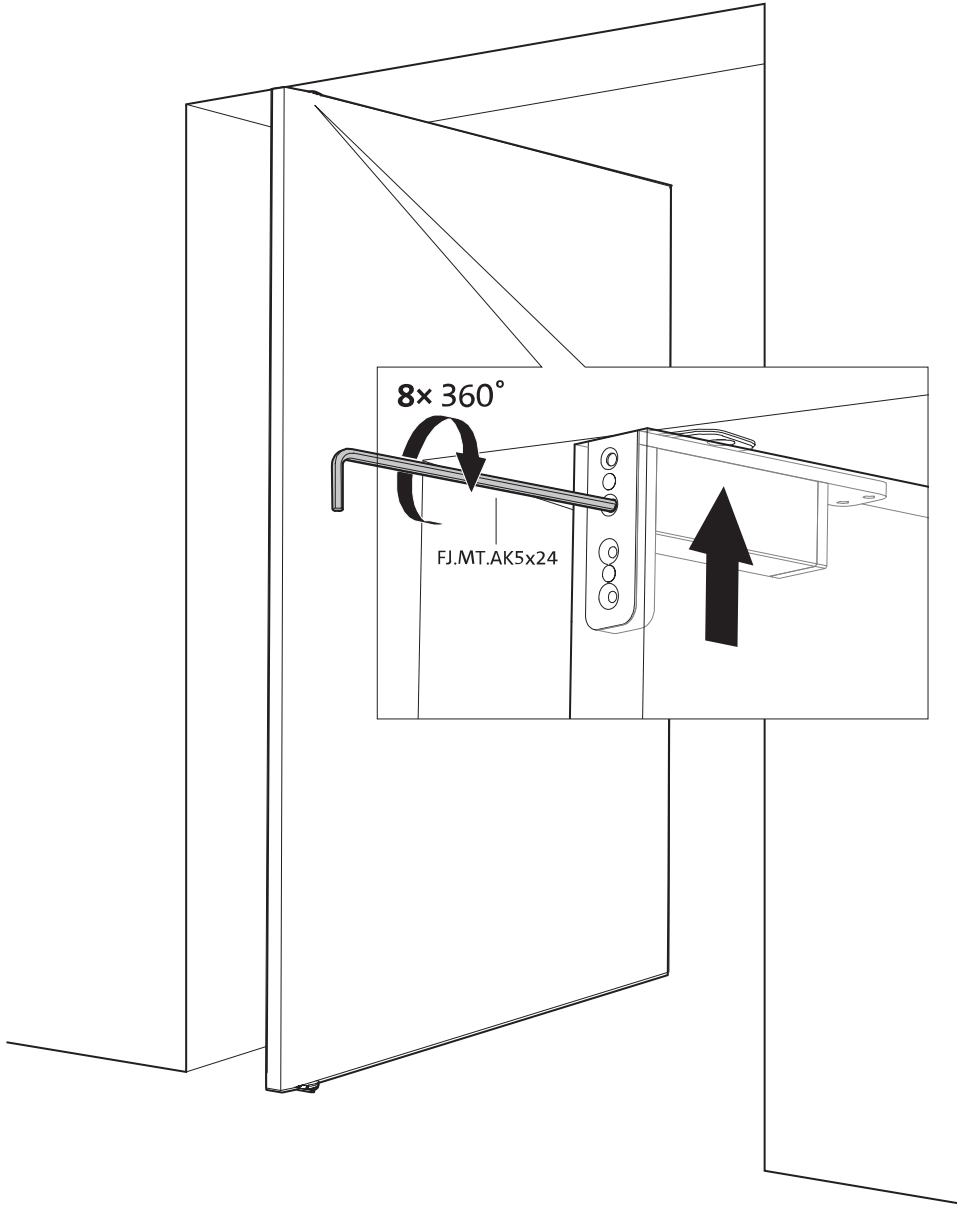
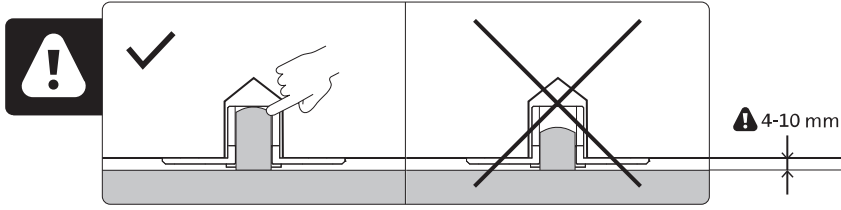

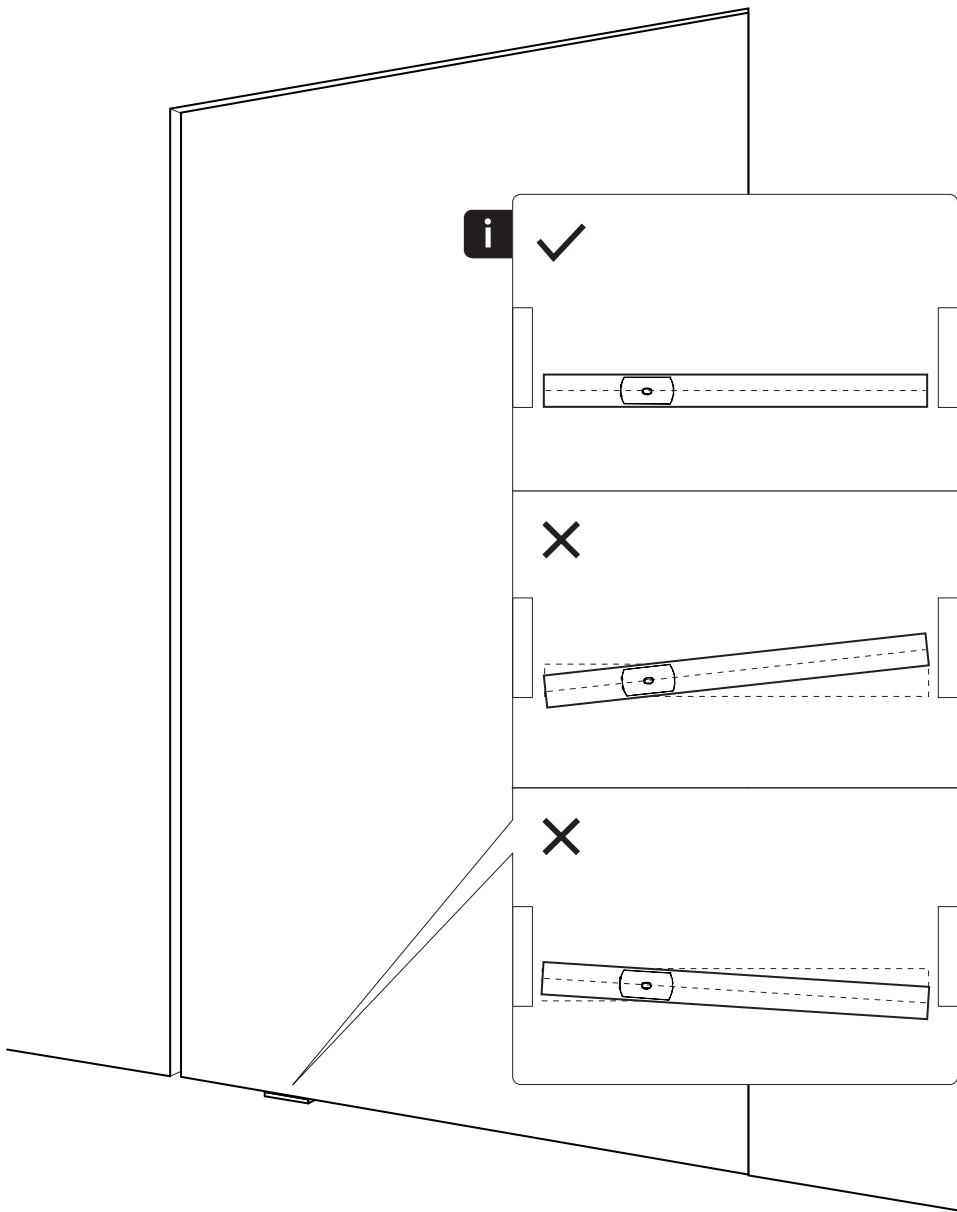

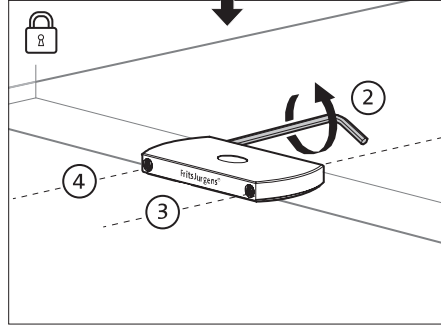
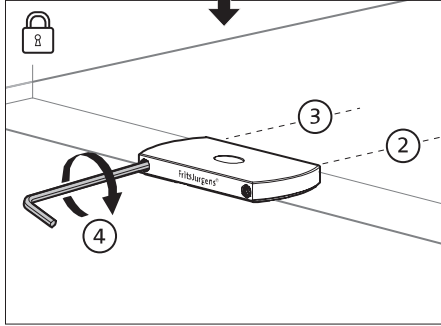
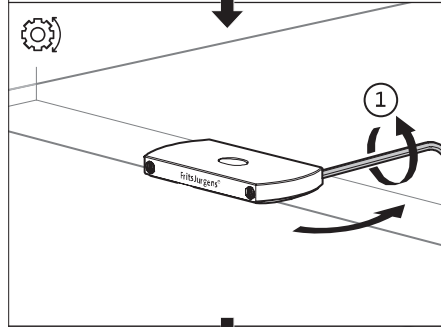
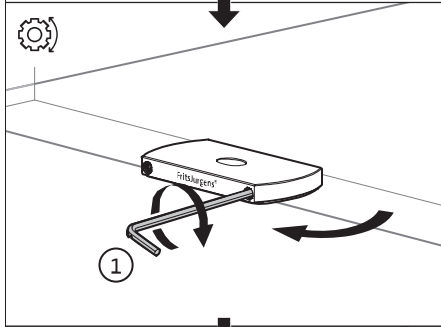
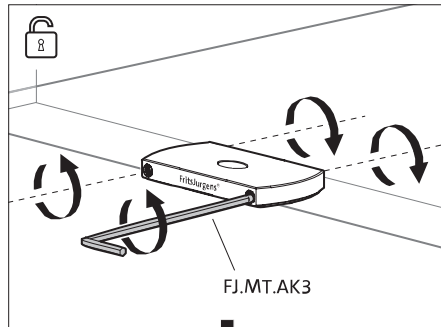
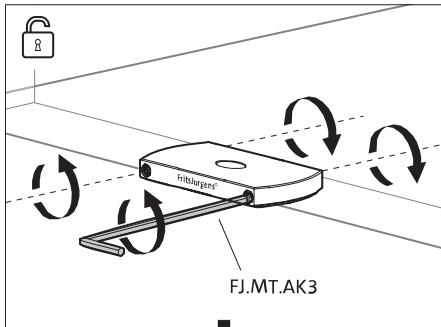
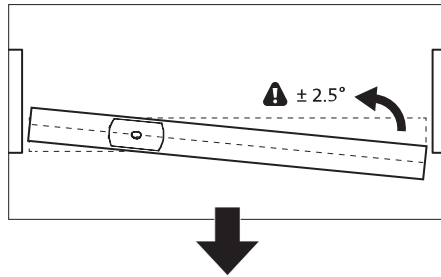
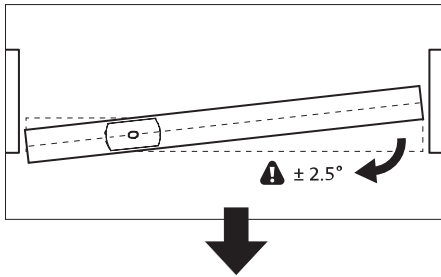

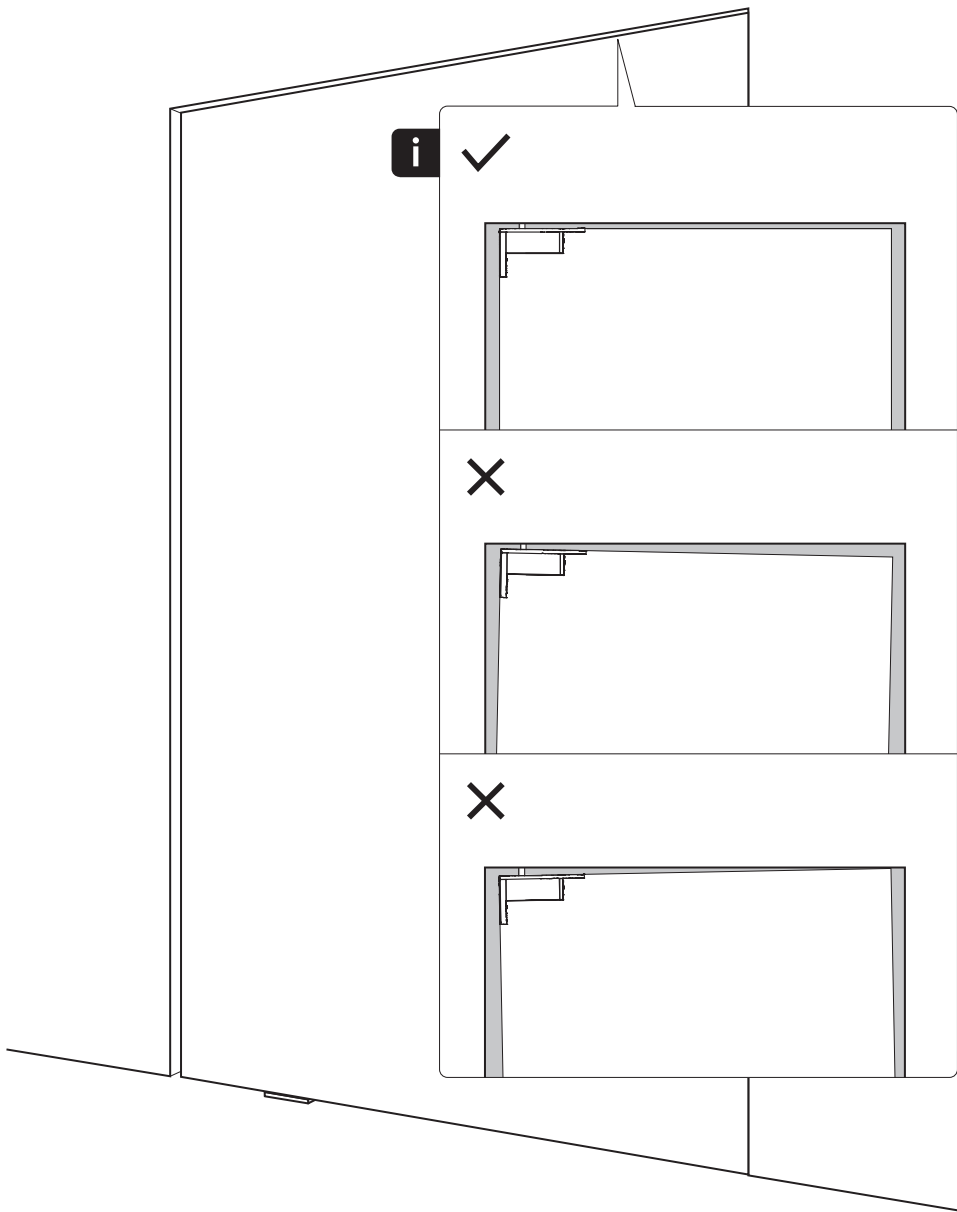

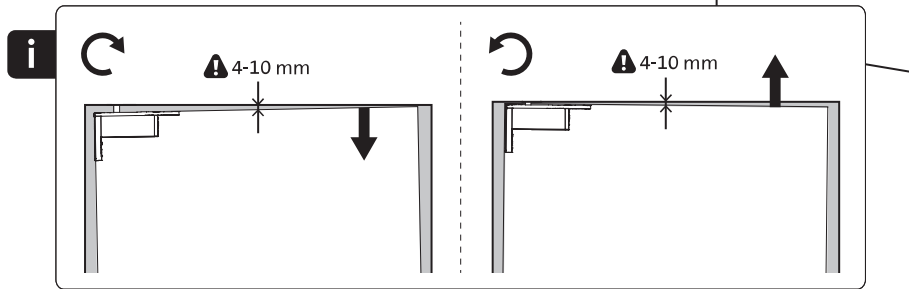
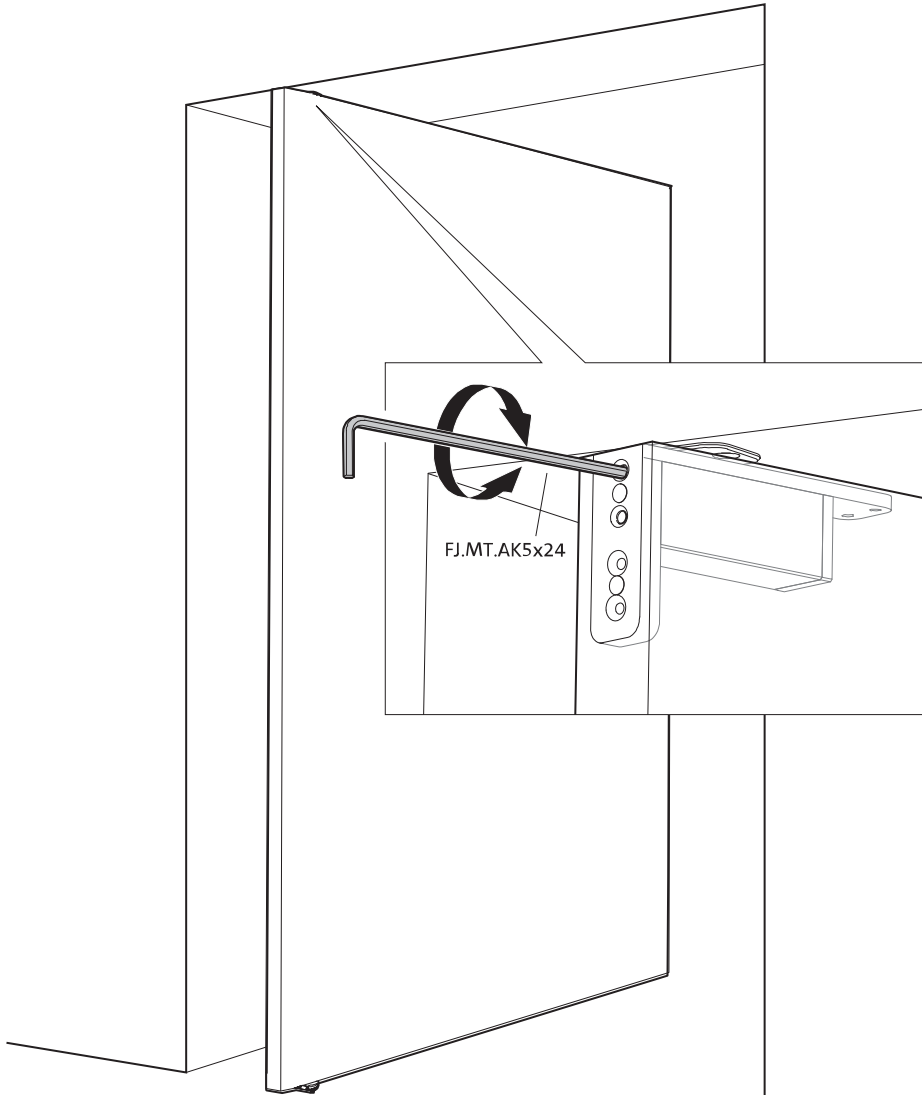

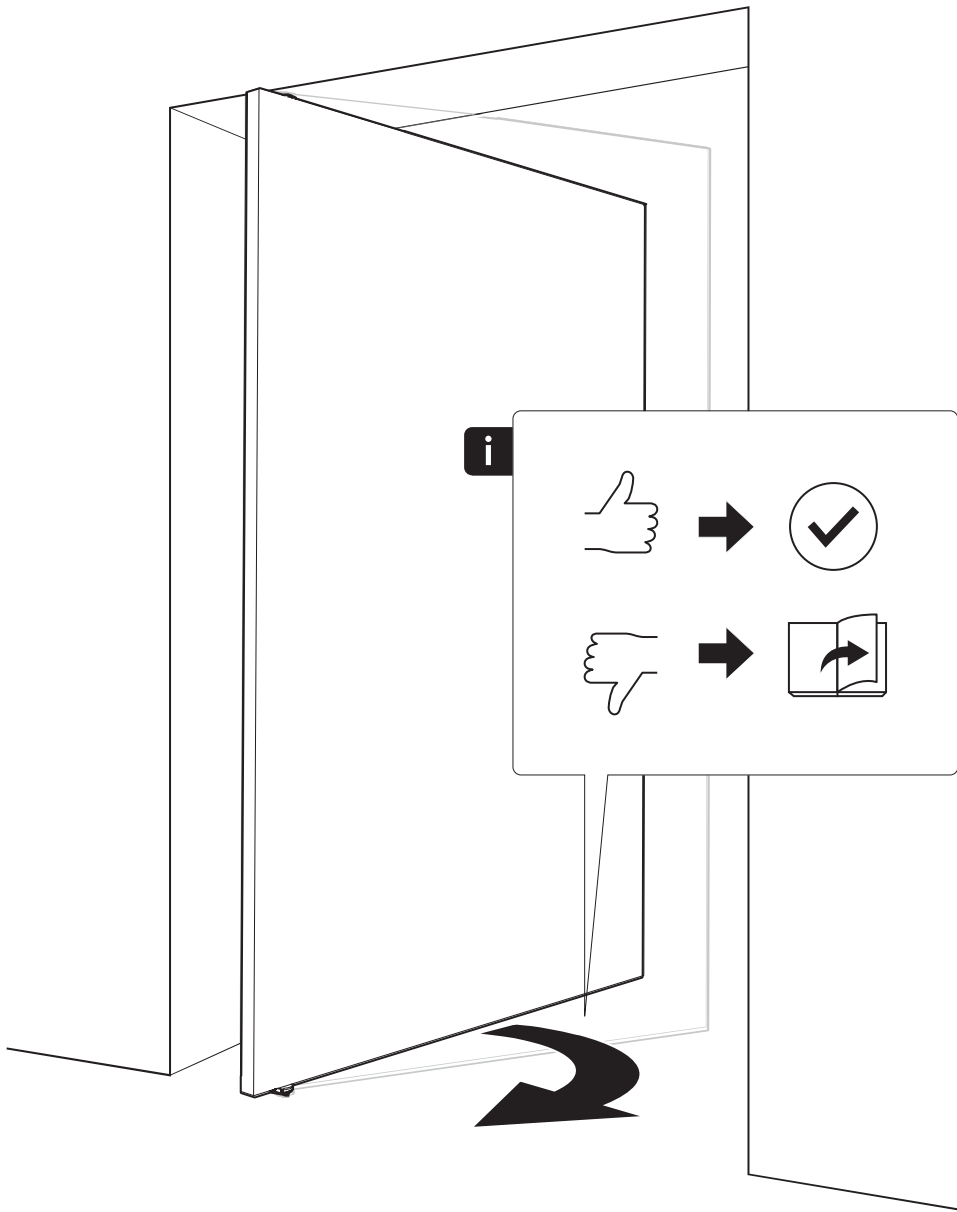



FJ.MT.AC.M+

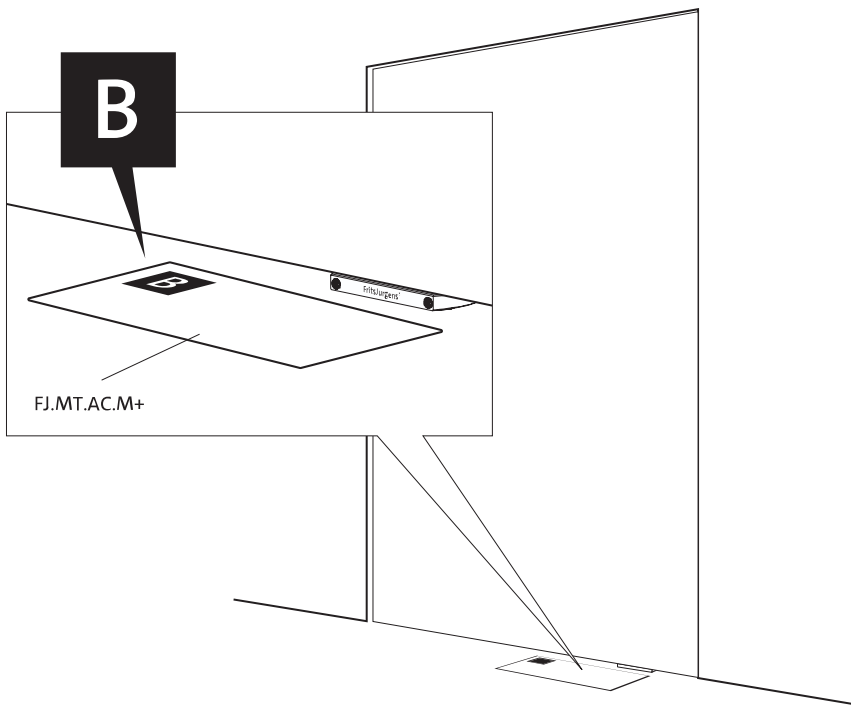
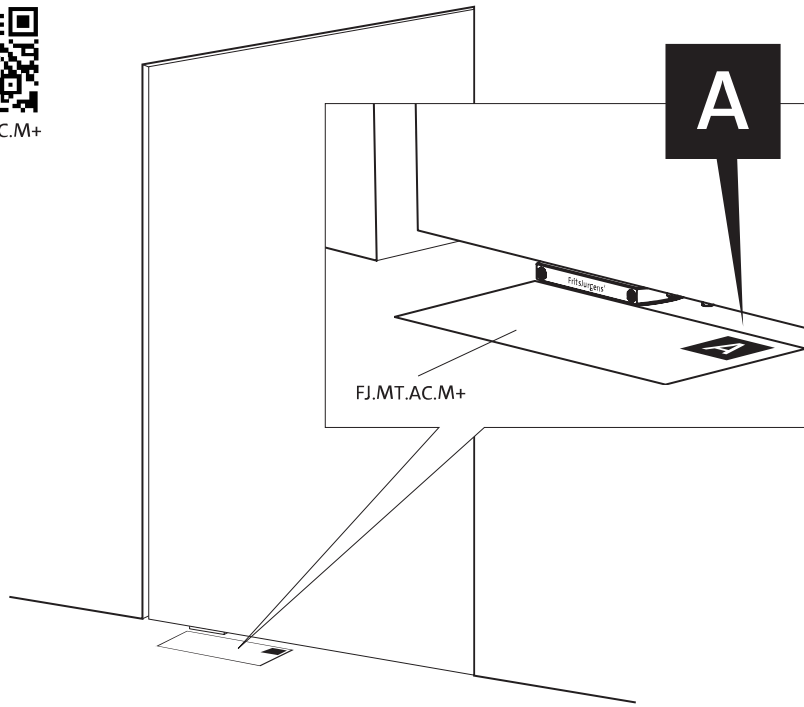

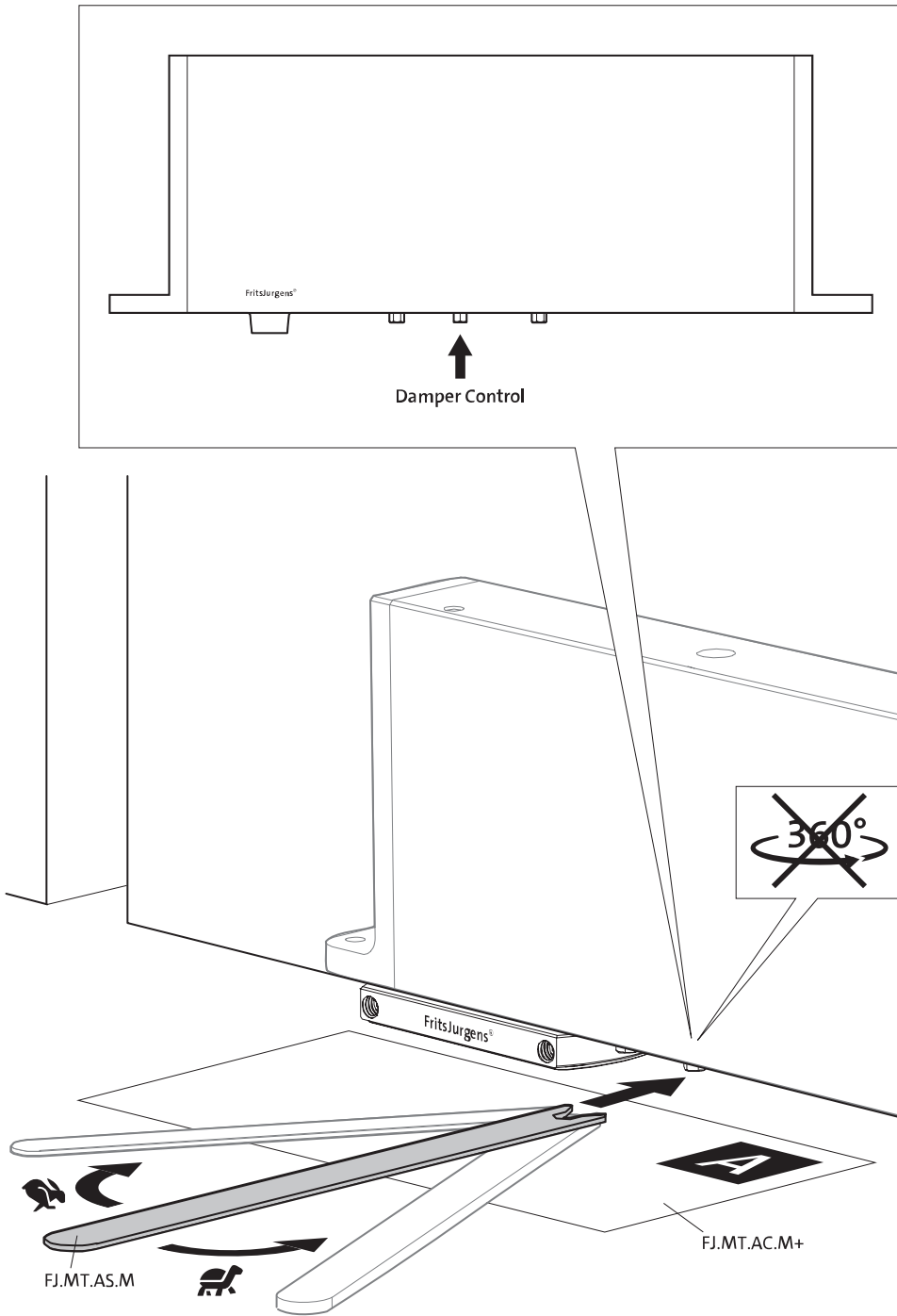

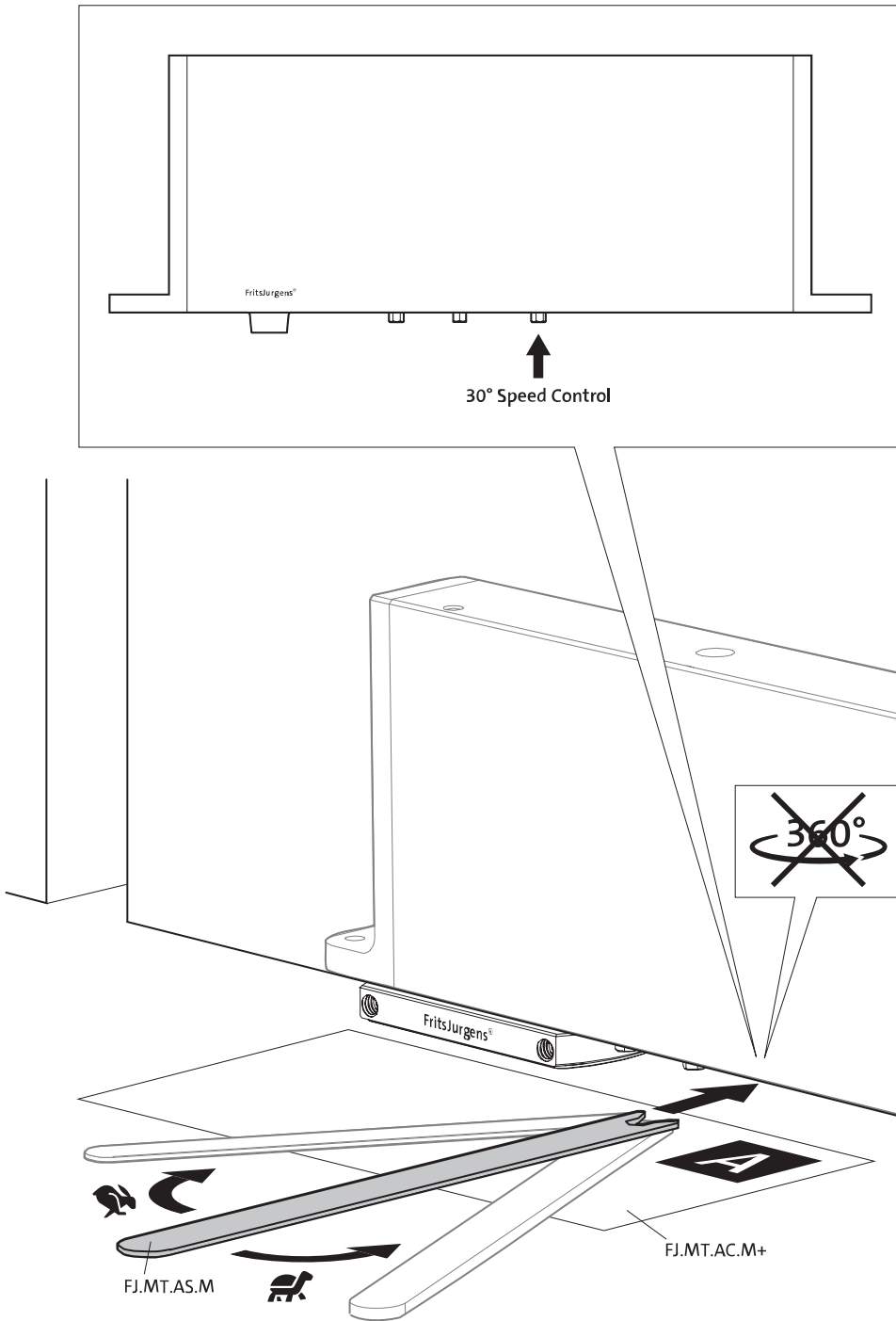

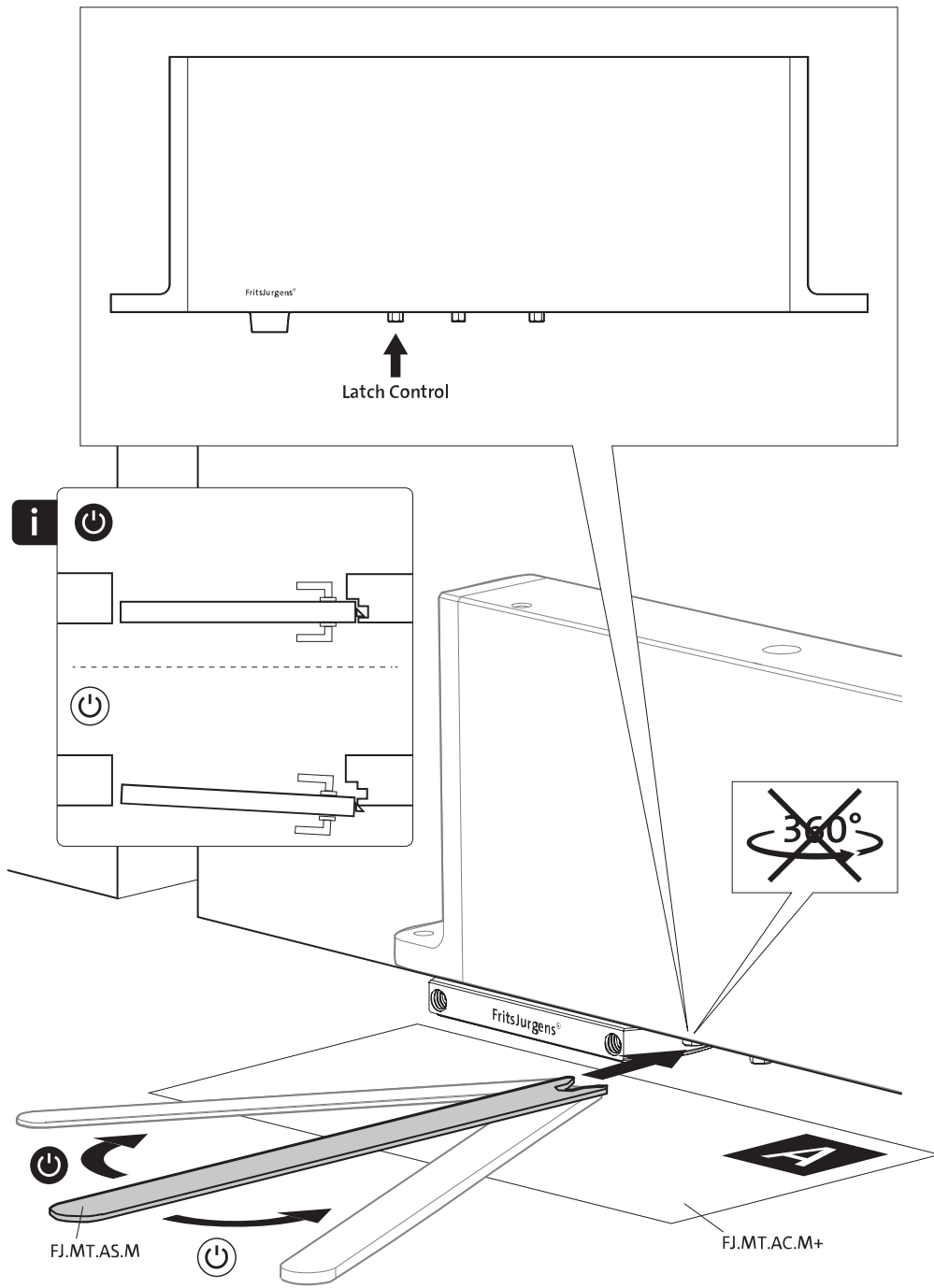

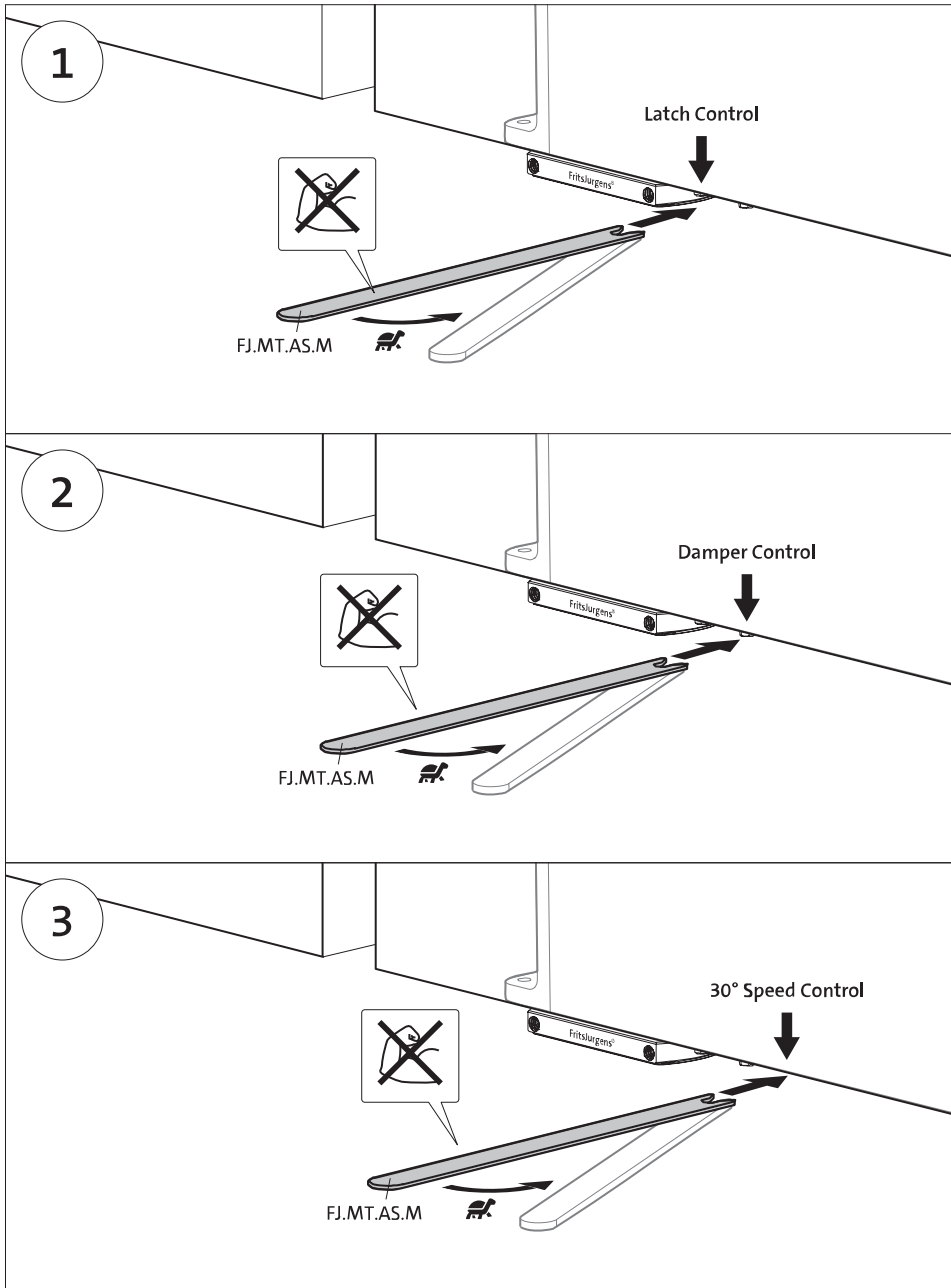

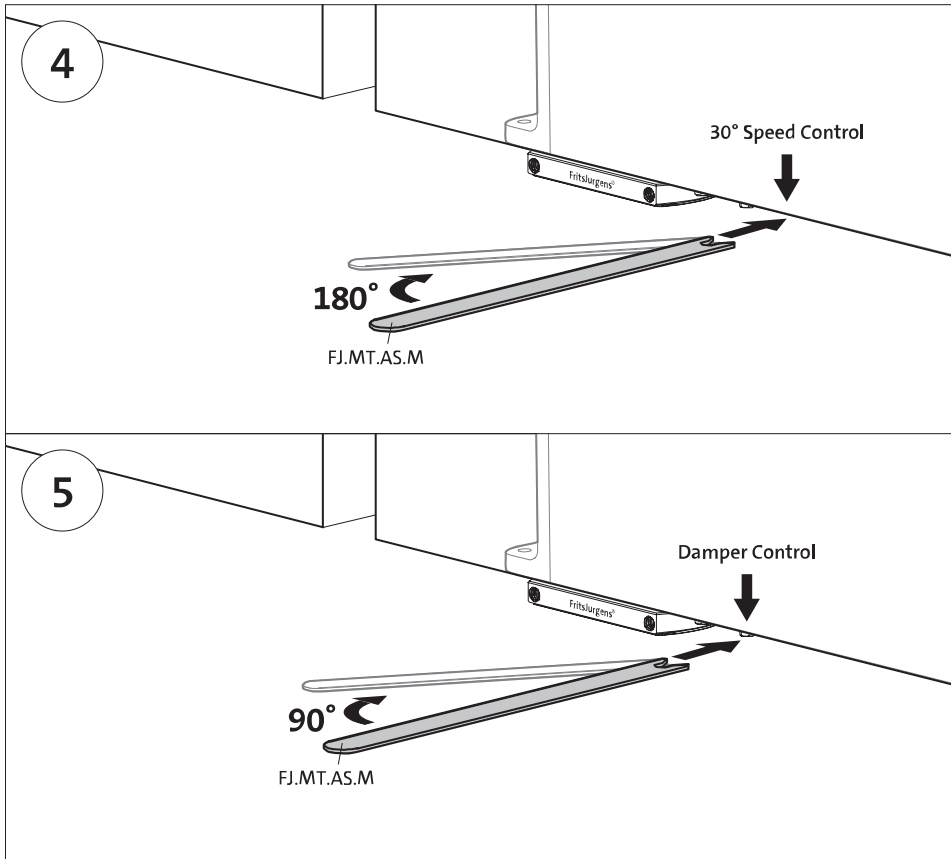

Instruções de desmontagem

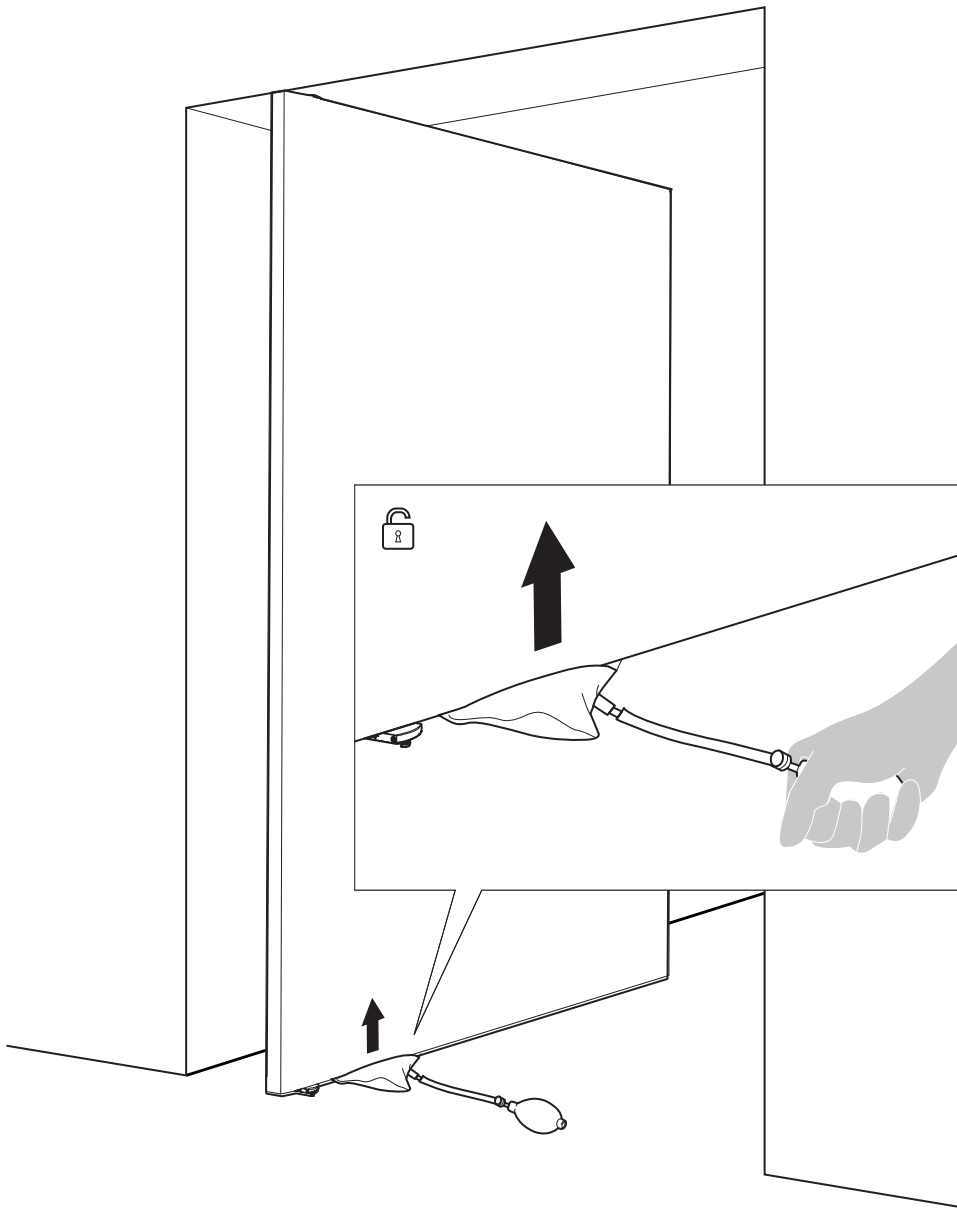

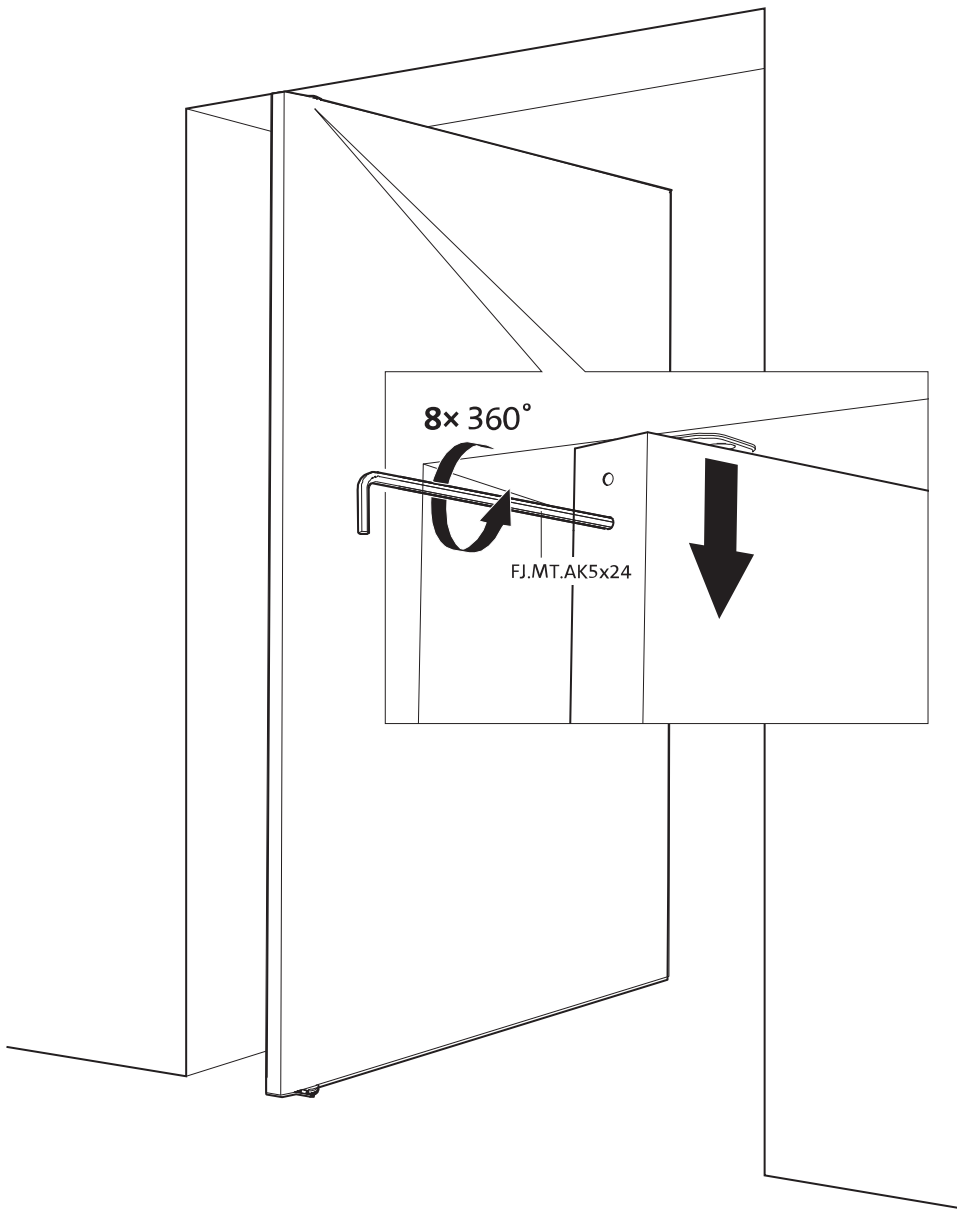

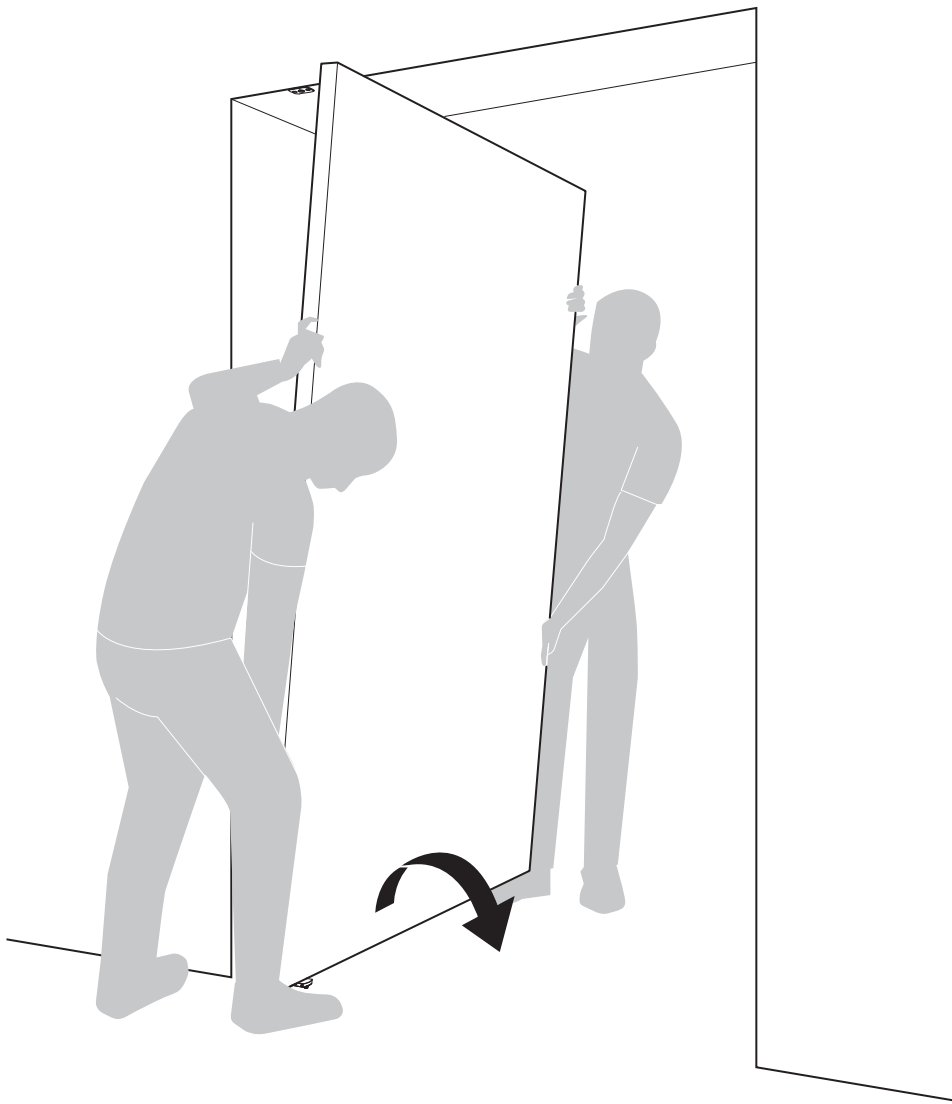

FritsJurgens International

A. Einsteinlaan 1
Os Países Baixos
9615 TE Kolham
+31 598 343 410
info@fritsjurgens.com

FritsJurgens Dubai Branch

DLC-OP-A2-4-0029
Dubai South
Dubai
Emirados Árabes Unidos
+971 4 820 8106
+971 58 137 2611
dubai@fritsjurgens.com
fritsjurgens.com

Copyright © FritsJurgens®
BPM+.40.G.X.SS

